

# CK Engineering LLC.

19105 36th Ave. W, Suite 205  
Lynnwood, WA 98036

Phone: (206) 417-0670

## STRUCTURAL CALCULATIONS

Lateral & Gravity Design  
19-061



1/13/2020

TIMBERLAND  
9027 SE 60th ST.  
Mercer Island, WA 98040  
January 13, 2020

**Search Information**

**Address:** 9027 se 60th mercer island  
**Coordinates:** 47.5489591, -122.2176389  
**Elevation:** ft  
**Timestamp:** 2019-12-10T01:33:58.510Z  
**Hazard Type:** Seismic  
**Reference Document:** IBC-2015  
**Risk Category:** II  
**Site Class:** D



**MCE<sub>R</sub> Horizontal Response Spectrum**

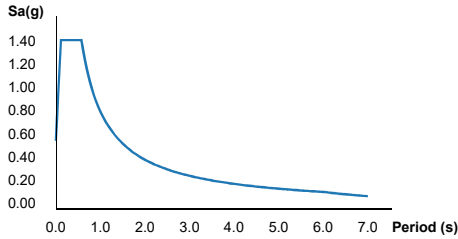

**Design Horizontal Response Spectrum**

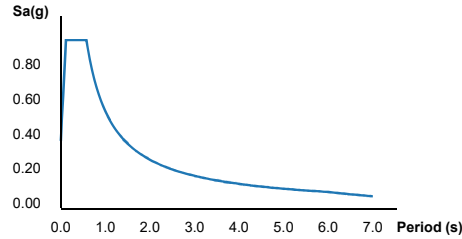

**Basic Parameters**

Name	Value	Description
S <sub>S</sub>	1.451	MCE <sub>R</sub> ground motion (period=0.2s)
S <sub>1</sub>	0.556	MCE <sub>R</sub> ground motion (period=1.0s)
S <sub>MS</sub>	1.451	Site-modified spectral acceleration value
S <sub>M1</sub>	0.835	Site-modified spectral acceleration value
S <sub>DS</sub>	0.968	Numeric seismic design value at 0.2s SA
S <sub>D1</sub>	0.556	Numeric seismic design value at 1.0s SA

**Additional Information**

Name	Value	Description
SDC	D	Seismic design category
F <sub>a</sub>	1	Site amplification factor at 0.2s
F <sub>v</sub>	1.5	Site amplification factor at 1.0s
CR <sub>S</sub>	0.948	Coefficient of risk (0.2s)
CR <sub>1</sub>	0.928	Coefficient of risk (1.0s)
PGA	0.603	MCE <sub>G</sub> peak ground acceleration
F <sub>PGA</sub>	1	Site amplification factor at PGA
PGA <sub>M</sub>	0.603	Site modified peak ground acceleration
T <sub>L</sub>	6	Long-period transition period (s)
S <sub>sRT</sub>	1.451	Probabilistic risk-targeted ground motion (0.2s)
S <sub>sUH</sub>	1.53	Factored uniform-hazard spectral acceleration (2% probability of exceedance in 50 years)
S <sub>sD</sub>	3.588	Factored deterministic acceleration value (0.2s)
S <sub>1RT</sub>	0.556	Probabilistic risk-targeted ground motion (1.0s)
S <sub>1UH</sub>	0.6	Factored uniform-hazard spectral acceleration (2% probability of exceedance in 50 years)
S <sub>1D</sub>	1.308	Factored deterministic acceleration value (1.0s)
PGAd	1.37	Factored deterministic acceleration value (PGA)

The results indicated here DO NOT reflect any state or local amendments to the values or any delineation lines made during the building code adoption process. Users should confirm any output obtained from this tool with the local Authority Having Jurisdiction before proceeding with design.



# Mercer Island Wind Exposure and Wind Speed-Up (Topographic Effect)

by Development Services Group (DSG), City of Mercer Island  
April 2009

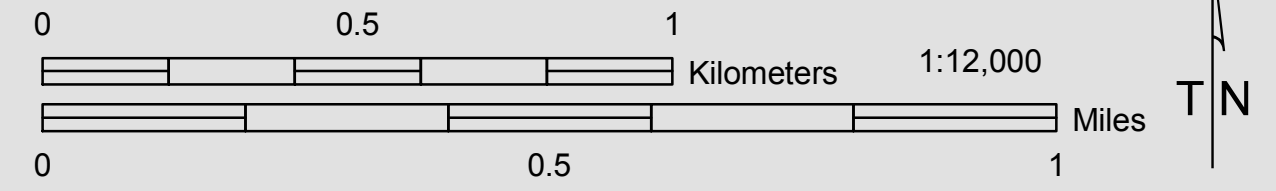

## WIND EXPOSURE CATEGORIES & WIND SPEED-UP FACTORS (ICC Section 1609 & ASCE 7-05 Chapter 6)

It is the responsibility of the Owner (or their Design Professional) to review site conditions and determine the  $K_{zt}$  factor to be utilized for each specific project. The  $K_{zt}$  factors and wind exposure categories indicated on this map are the minimum values accepted by the City of Mercer Island without requiring the design professional to submit additional calculations and supporting topographic documentation (to verify the values utilized in their wind load determination).

Please note – The  $K_{zt}$  values indicated on this map are approximations based upon periodic calculations of representative samplings around Mercer Island. These values are intended for City of Mercer Island's plan review purposes only.

### WIND EXPOSURE CATEGORIES:

Wind Exposure Category		Exposure 'C' (1500 feet from Lake)
		Exposure 'B' (all other areas)

### WIND SPEED-UP (TOPOGRAPHIC EFFECT) - $K_{zt}$ Factor :

$K_{zt}$ Factor		$K_{zt} = 1.0$
		$K_{zt} = 1.3$
		$K_{zt} = 1.6$
		$K_{zt} = 1.9$

### GENERAL NOTES FOR WIND EXPOSURE AND WIND SPEED-UP MAP

This map is the Wind Exposure Category and Wind Speed-up (Topographic Effects) Map for the City of Mercer Island. This map shows the minimum wind exposure category and the minimum wind speed-up, " $K_{zt}$ " factor, which will be accepted without site specific documentation and calculation.

Other wind speed phenomena may occur on Mercer Island that is not specifically identified on this map. It is the responsibility of the Owner (or their Design Professional) to review site conditions and determine the appropriate design wind speed and exposure category for their specific project and location.

This map is for the sole use of the staff of the City of Mercer Island's Development Services Group (DSG) for the purposes of permit application evaluation. This map provides DSG staff a general assessment of Wind Exposure Category and Wind Speed-up (Topographic Effects). All areas have not been specifically evaluated and there may be locations that are not correctly represented on this map. It is the responsibility of individual property owners and map users to evaluate risk associated with their proposed development. No site-specific assessment of risk is implied or otherwise indicated by the City of Mercer Island with this map.

Information about data used for the map, references, and data limitation are all described the associated "Read Me" document. The digital version of this map is accompanied by a meta data file containing pertinent information about map construction. This data map is available on the City of Mercer Island website.

The City of Mercer Island is using guidance provided within ICC Section 1609 & ASCE 7-05 Chapter 6 regarding definitions used when creating this map.

### DEFINITIONS:

**$K_{zt}$  factor:** The topographic effect of wind speed-up at isolated hills, ridges, and escarpments constituting abrupt changes in the general topography, located in any exposure category, that meet all of the conditions noted in ASCE 7-05 Minimum Design Loads for Buildings and Other Structures, Section 6.5.7.

**Exposure B:** The wind exposure category that applies where the site in question is located a minimum of 1500 feet from the shoreline and the mean roof height is less than or equal to 30 feet per IBC 2006 section 1609.4.3.

**Exposure C:** The wind exposure category that applies where the site in question is located within 1500 feet from the shoreline per IBC 2006 section 1609.4.3.

**Wind Speed:** Minimum 85 mph 3-second gust per IRC Figure R301.2(4)

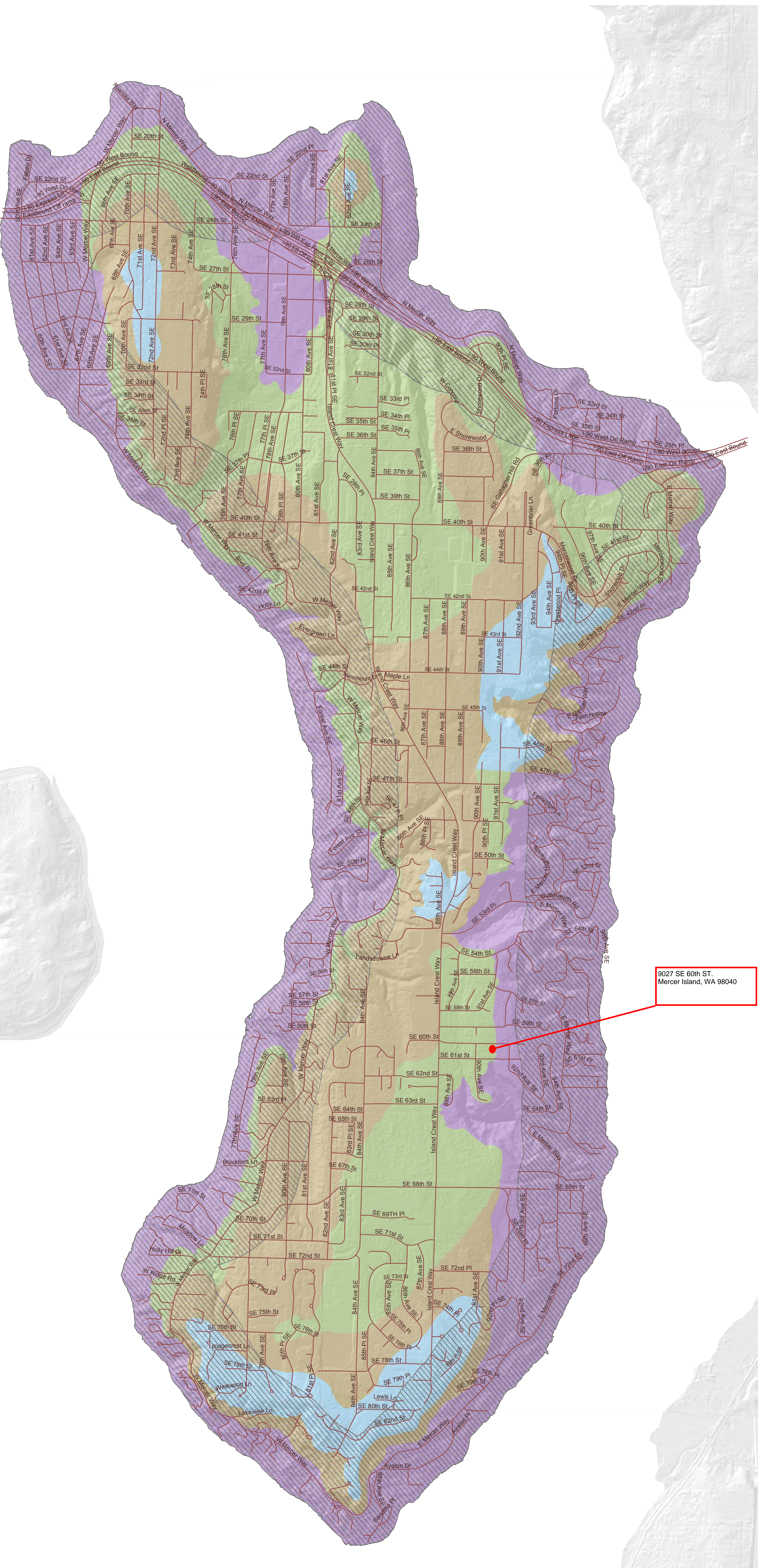

9027 SE 60th ST,  
Mercer Island, WA 98040

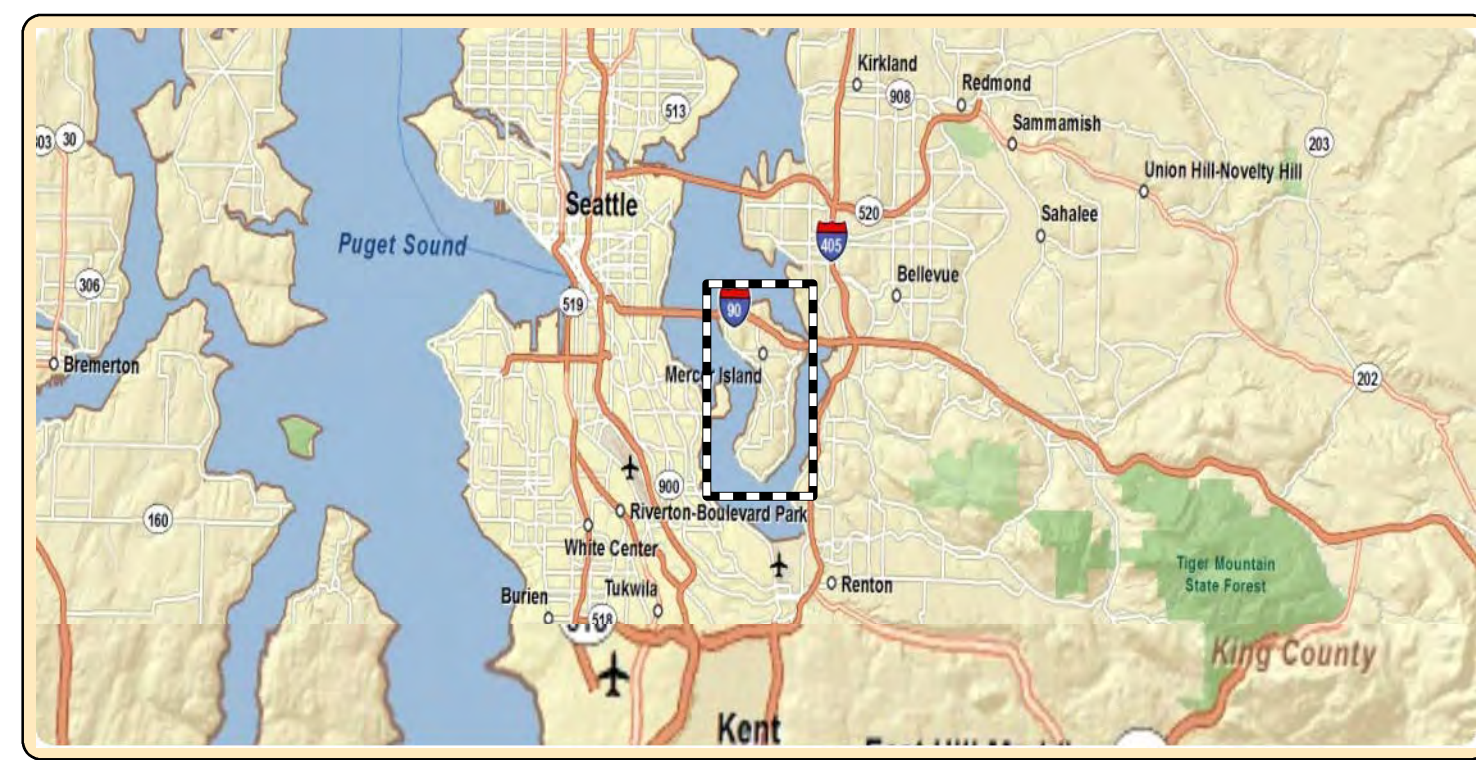



## Design Criteria

Scope of Work:	Lateral & Gravity Design		
Site Address:	9027 SE 60th ST. Mercer Island, WA 98040		
Number of Stories:	2	Engineer:	PK

## Roof Loading

Roofing	Composition	3.0
Sheathing	5/8" Plywood	1.8
Insulation	Roll/Batt	3.0
Ceiling	5/8" GWB	2.8
Framing	Trusses	2.2
Miscellaneous	fixtures, mechanical, electrical, etc.	2.2
TOTAL DEAD LOAD:		15.0 psf
ROOF SNOW LOAD:		25.0 psf

## Upper Floor Loading

Floor Covering	Carpet/Hardwood/Tile	3.0
Sheathing	3/4" T&G	2.3
Ceiling	1/2" GWB	2.2
Joists	Solid Sawn @ 16" o/c	3.3
Beams		2.8
Miscellaneous	fixtures, mechanical, electrical, etc.	1.4
TOTAL DEAD LOAD:		15.0 psf
FLOOR LIVE LOAD:		40.0 psf

## Main Floor Loading

Floor Covering	Carpet/Hardwood/Tile	3.0
Sheathing	3/4" T&G	2.3
Ceiling	5/8" GWB	2.8
Joists	I-Joists	2.1
Beams		4.2
Miscellaneous	fixtures, mechanical, electrical, etc.	0.6
TOTAL DEAD LOAD:		15.0 psf
FLOOR LIVE LOAD:		40.0 psf

Soil Bearing Capacity:	1500 psf
Frost Depth:	18 in

# LATERAL & GRAVITY DESIGN KRY PLANS

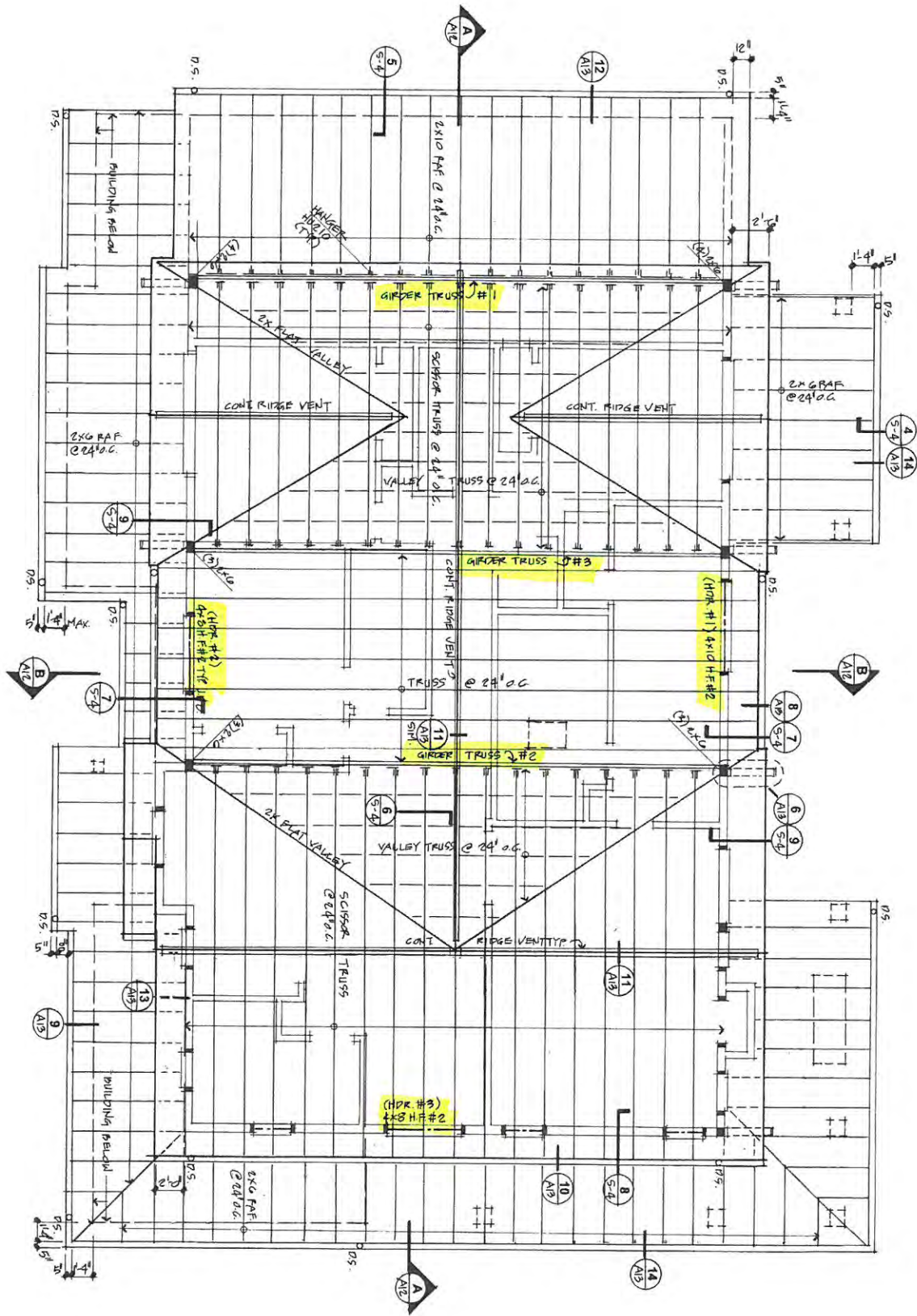

Handwritten initials or signature.

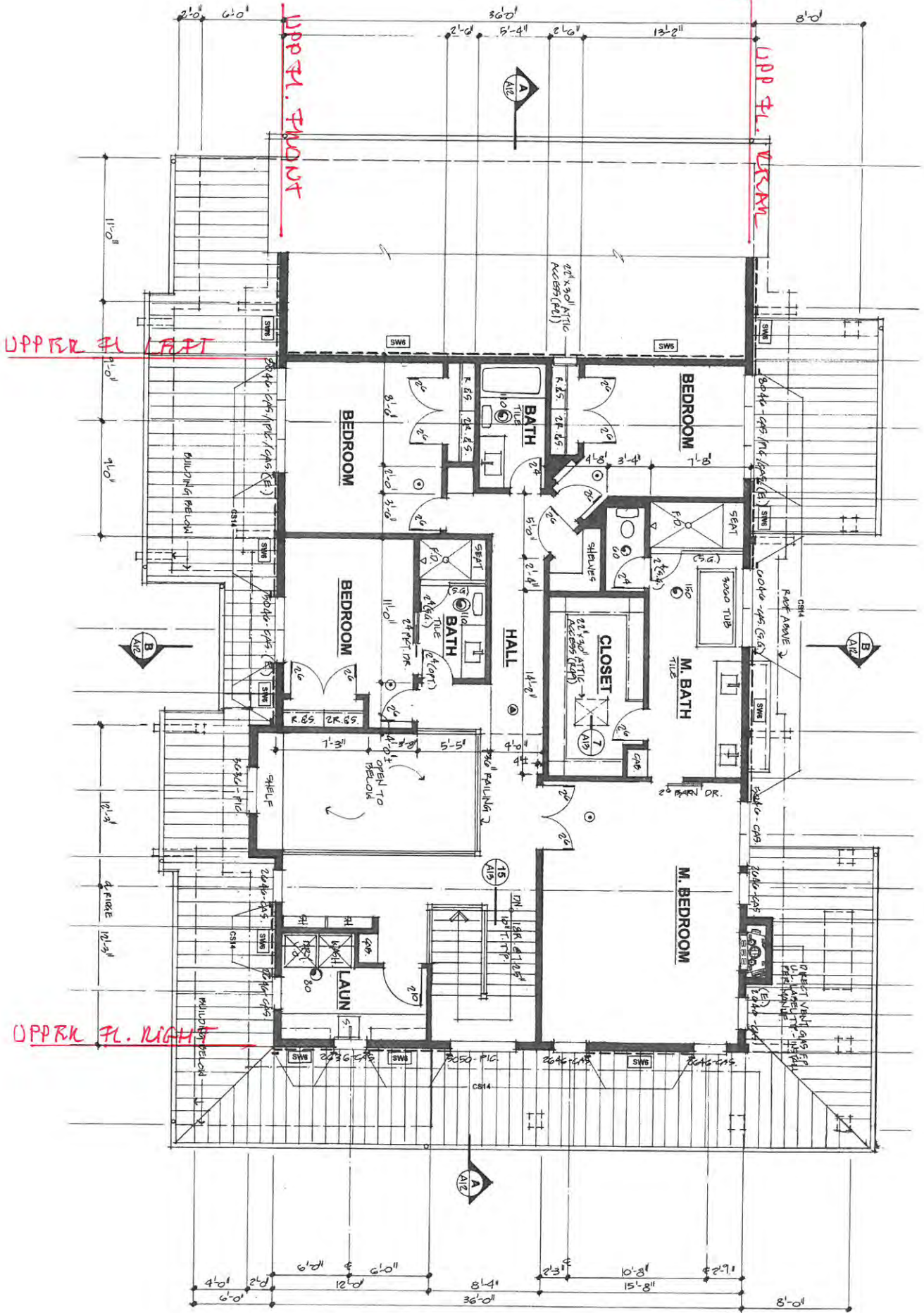



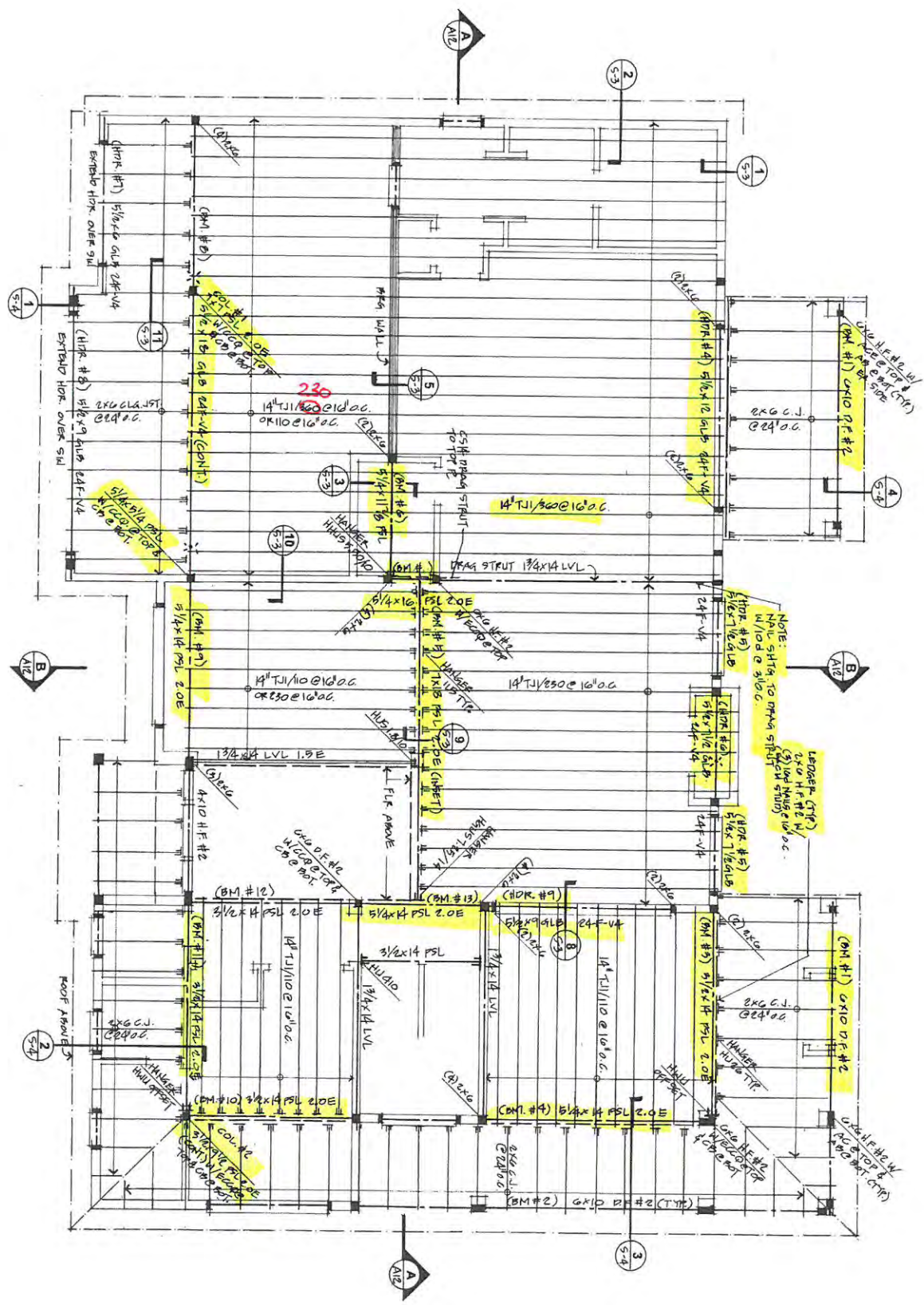

NOTE:  
 (1) 2x0 H.F.B.W. / W/od @ 510c  
 (2) 1x6 H.F.B.W. / W/od @ 510c  
 (3) 1x6 H.F.B.W. / W/od @ 510c

LEADER (TOP)  
 2x0 H.F.B.W. / W/od @ 510c

2x0 H.F.B.W. / W/od @ 510c

PLAN.  
ALL DIMENSIONS  
UNLESS OTHERWISE  
NOTED ARE IN FEET  
& INCHES.  
DIMENSIONS IN PARENTHESES  
ARE FOR REFERENCE ONLY.  
DIMENSIONS IN SQUARE  
BRACKETS ARE FOR  
CONSTRUCTION ONLY.

ALL BE  
ROOFED.  
EXPOSED  
PIPE WITH  
INSULATION  
SHOWN  
UNLESS  
NOTED  
OTHERWISE.

BE PROVIDED TO CUT  
AND REMOVE ALL  
EXISTING PARTS  
AND REPAIR AND  
FINISH AS SHOWN  
HEREIN. ALL WORK  
TO BE PROVIDED IN  
ACCORDANCE WITH  
THE SPECIFICATIONS  
AND CONDITIONS OF  
CONTRACT.

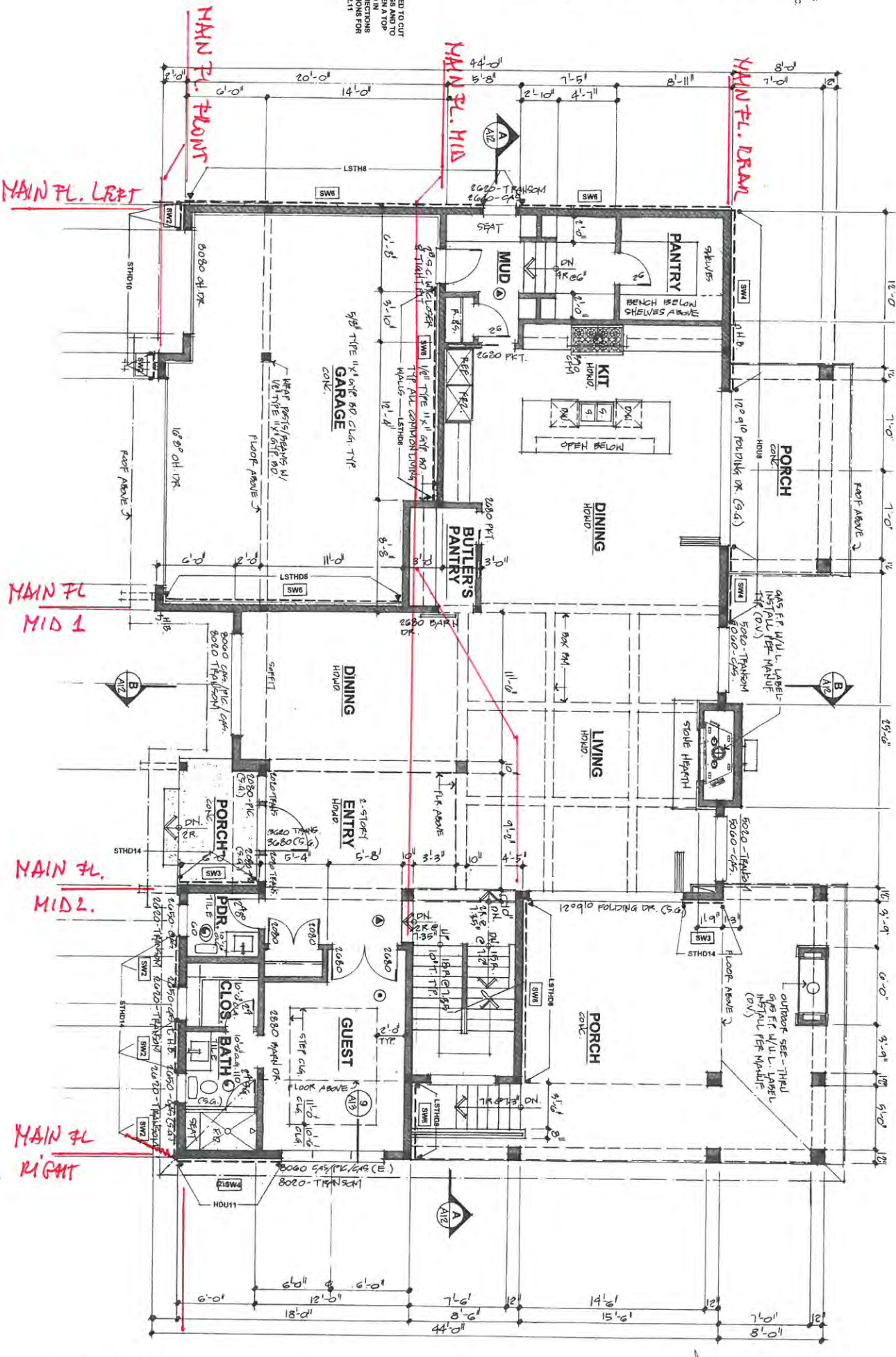

**MAIN FL. FRONT**

**MAIN FL. MID**

**MAIN FL. REAR**

**MAIN FL. LEFT**

**MAIN FL. MID 1**

**MAIN FL. MID 2**

**MAIN FL. RIGHT**



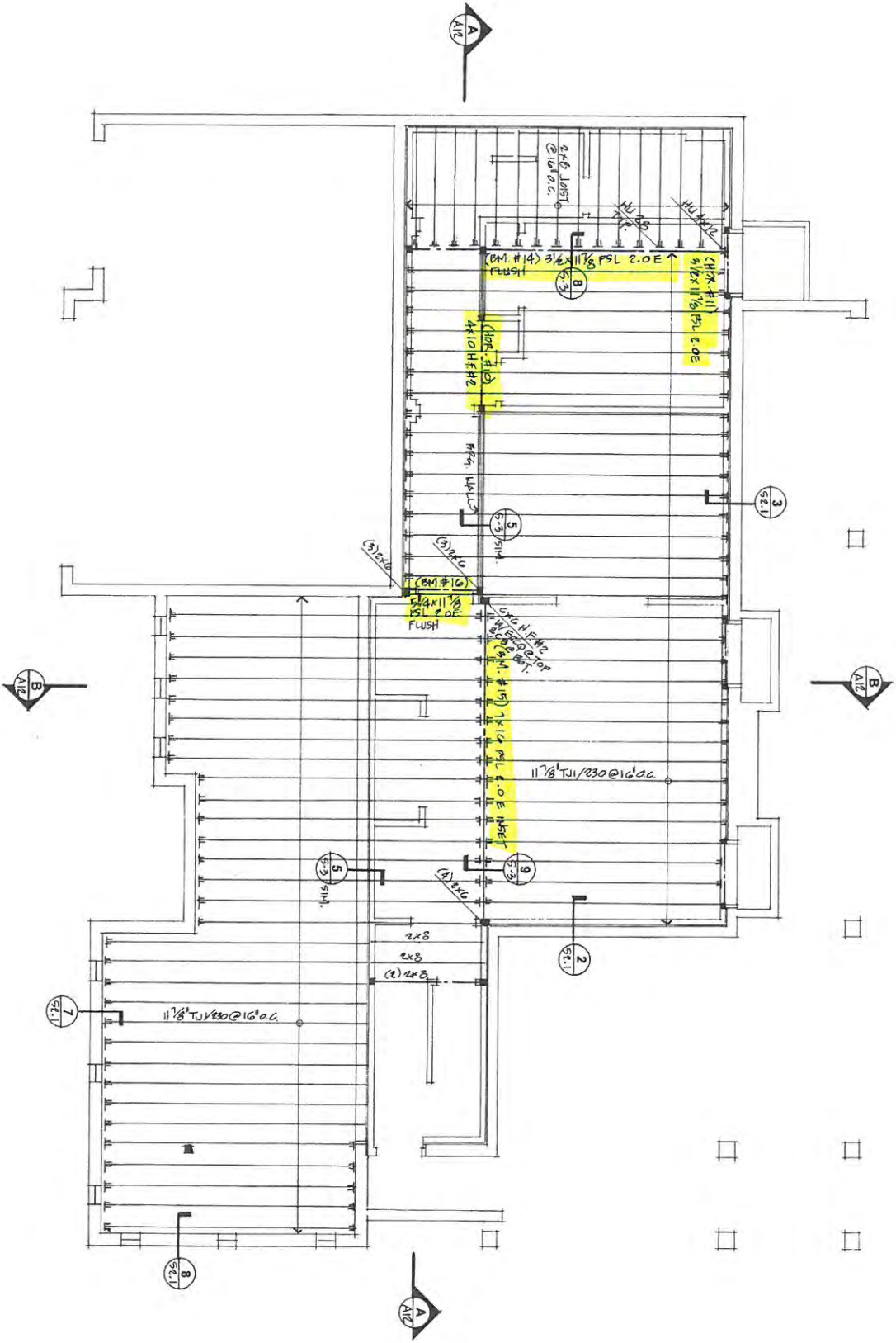

1 2 3 4 5 6 7 8 9

1 2 3 4 5 6 7 8 9



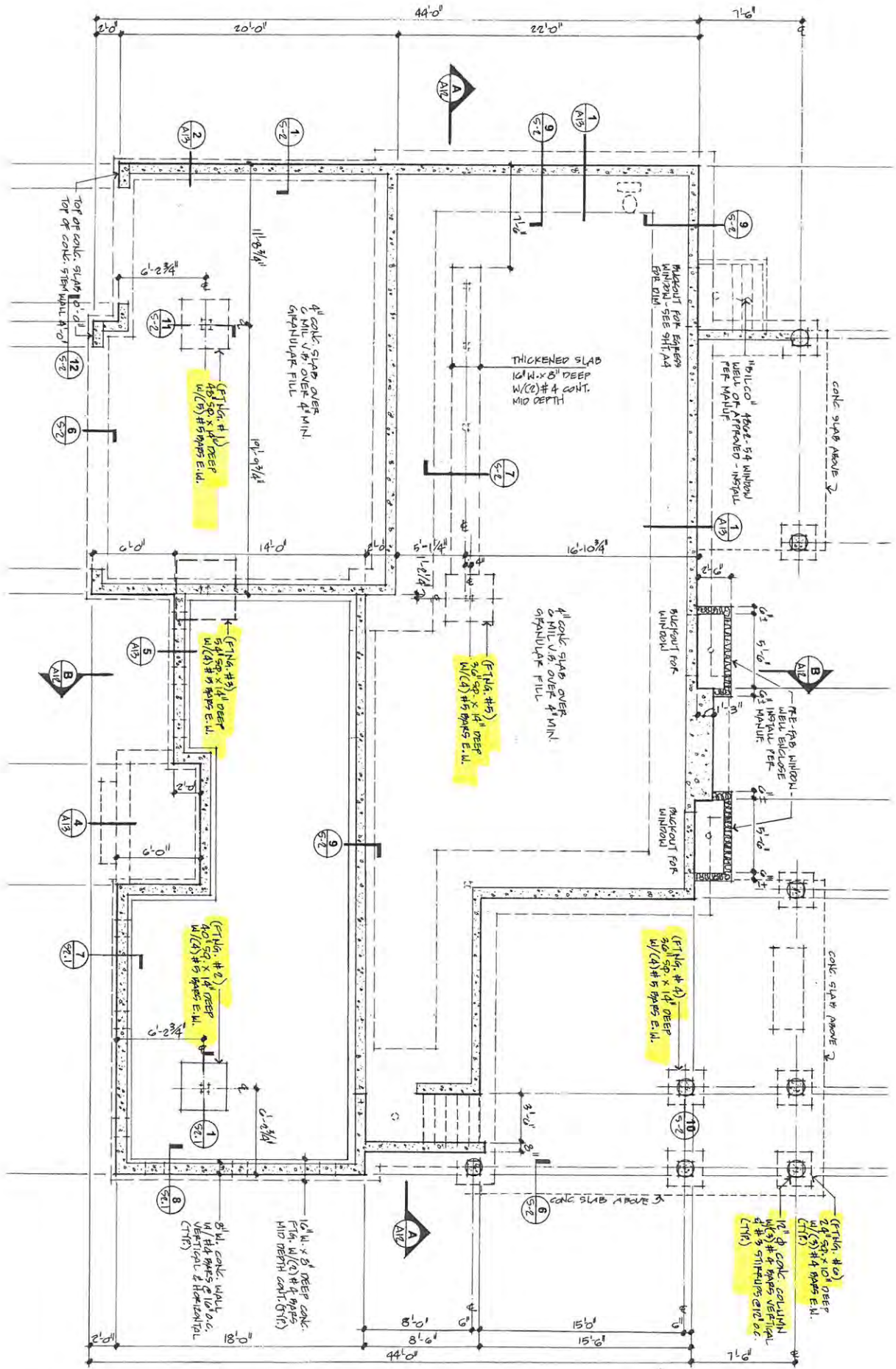

TOP OF CONCRETE SLAB 1'-0" DEEP  
TOP OF CONCRETE STEIN WALL 1'-0"

4" CONCRETE SLAB OVER  
CONCRETE WALL OVER 4" MIN.  
GRAVEL/BLANK FILL

(FT) 1/4" #3 1" DEEP  
W/ (3) #5 BARS E.W.

THICKENED SLAB  
1'-0" W. X 8" DEEP  
W/ (2) #4 CONT.  
MID DEEP

MUDJACK FOR  
WINDOW - SEE SHT. A4  
EPL. DIM.

1'-0" W. X 8" DEEP  
WELL OF APPROX. 5" MINIMUM  
REF. W/BLUR

CONCRETE SLAB ABOVE

4" CONCRETE SLAB OVER  
CONCRETE WALL OVER 4" MIN.  
GRAVEL/BLANK FILL

(FT) 1/4" #3 1" DEEP  
W/ (4) #5 BARS E.W.

MUDJACK FOR  
WINDOW

1'-0" W. X 8" DEEP  
WELL ENCLOSE  
WITH INSTALL  
REF. W/BLUR

CONCRETE SLAB ABOVE

(FT) 1/4" #4 1" DEEP  
W/ (4) #5 BARS E.W.

(FT) 1/4" #2 1" DEEP  
W/ (3) #5 BARS E.W.

1'-0" W. X 8" DEEP CONCRETE  
W/ (2) #4 BARS  
H/10 DEPTH CONCR. (FT)

8" W. CONCRETE WALL  
W/ 4" BARS OVER 1'-0" O.C.  
VERTICAL & HORIZONTAL  
(FT)

(FT) 1/4" #2 1" DEEP  
W/ (3) #4 BARS E.W.  
(FT)

1'-0" CONCRETE COLUMN  
W/ (3) #4 BARS VERTICAL  
& (3) STIFFENERS CIRC. C.  
(FT)



Type of construction: **New**  
 Applicable Building Codes: **IBC 2015, ASCE 7/SEI 7-10**

Location: **9027 SE 60th ST.  
 Mercer Island, WA 98040**

Work performed :

**Lateral & Gravity Design**

**WIND DESIGN:**

$$P_s = \lambda_w P_{s30} K_{zt}$$

Exposure : **B**  
 Wind Speed = **85 MPH**  
 $P_{s30} =$   
 $I_w =$  **1**  
 $\lambda =$  **1.00**  
 $K_{zt} =$  **1.30**

Wind Exposure Category as set forth in Section 26.7 of ASCE 7-10  
 Basic Wind Speed (LRFD) as used in Figure 28.6 of ASCE 7-10 and converted to (ASD)  
 Simplified design wind pressure for Exposure B, at h = 30 feet and for I = 1.0, from Figure 28.6-1  
 Importance factor as defined in Table 1.5-2 of ASCE 7-10  
 Adjustment factor for building height and exposure from Figure 28.6-1 of ASCE 7-10  
 Adjustment factor for increased wind speed due to a hill or escarpment from Section 26.8 of ASCE 7-10

Roof slope :

Front/Rear  $\tan^{-1} \left( \frac{5}{12} \right) = 22.6$  degrees  
 Left/Right  $\tan^{-1} \left( \frac{8}{12} \right) = 33.7$  degrees  
 Mean Elevation **0**

Number of floors: **2**

Average uplift (F/R) = **-9.2 psf** Based on wind zones 'G' and 'H'  
 Average uplift (R/L) = **-1.6 psf** Based on wind zones 'G' and 'H'

	End zone of wall		End zone of roof	
	Front/Rear	Left/Right	Front/Rear	Left/Right
$P_{s30} =$	A = 15.1 psf	12.9 psf	B = -0.8 psf	8.8 psf
$P_s =$	19.6 psf	16.8 psf	-1.0 psf	11.4 psf

	Interior zone of wall		Interior zone of roof	
	Front/Rear	Left/Right	Front/Rear	Left/Right
$P_{s30} =$	C = 10.5 psf	10.2 psf	D = 0.2 psf	7.0 psf
$P_s =$	13.6 psf	13.3 psf	0.2 psf	9.1 psf

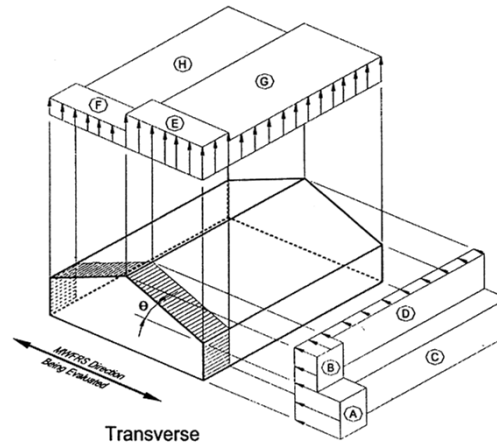

**WIND LOAD CALCULATIONS**  
**FRONT → REAR**

**ΣV 2ND FLOOR =**

WIND ZONE	B	B	B	A	A	C	C	C	D	C		
AVE. HEIGHT	2.5	7	6.5	7	4	2.5	6.5	10	9	3.5		
AVE. WIDTH	14	4.5	5	5	13	4.5	4.5	20	25	55		
$P_s$	0.00	0.00	0.00	19.65	19.65	13.64	13.64	13.64	0.21	13.64	0.00	0.00
SUBTOTAL	0	0	0	688	1022	153	399	2729	48	2626	0	0
<b>TOTAL</b>	8,440 lbs		Minimum net pressure controls. The calc. pressure is less than the min. net pressure, equal to 16psf(A-C), and 8psf(B-D) applied over the entire area. (ASCE 7-10 28.6.4)									

**ΣV 1ST FLOOR =**

WIND ZONE	A	A	C	D	C	C						
AVE. HEIGHT	4	10.5	2.5	4	4.5	3						
AVE. WIDTH	4	13	55	55	63	4						
$P_s$	19.65	19.65	13.64	0.21	13.64	13.64	0.00	0.00	0.00	0.00	0.00	0.00
SUBTOTAL	314	2682	1876	47	3868	164	0	0	0	0	0	0
<b>TOTAL</b>	8,951 lbs											

**NOT USED**

WIND ZONE												
AVE. HEIGHT												
AVE. WIDTH												
$P_s$	0.00	0.00	0.00	0.00	0.00	0.00	0.00	0.00	0.00	0.00	0.00	0.00
SUBTOTAL	0	0	0	0	0	0	0	0	0	0	0	0
<b>TOTAL</b>	0 lbs											



WIND LOAD CALCULATIONS  
LEFT → RIGHT

ΣV 2ND FLOOR =

WIND ZONE	B	B	A	A	D	C	C	C	D	C		
AVE. HEIGHT	5	4.5	4	4.25	5	5.5	8	10	10	4		
AVE. WIDTH	11	5.5	5.5	11	5	5	10	10	11	19		
Ps	11.44	11.44	16.77	16.77	9.10	13.26	13.26	13.26	9.10	13.26	0.00	0.00
SUBTOTAL	629	283	369	784	228	365	1061	1326	1001	1008	0	0
TOTAL	7,053 lbs											

ΣV 1ST FLOOR =

WIND ZONE	A	A	A	C	D	C						
AVE. HEIGHT	3.5	4.5	11	10.75	8	2.75						
AVE. WIDTH	5.5	1.25	10	28	10	9						
Ps	16.77	16.77	16.77	13.26	9.10	13.26	0.00	0.00	0.00	0.00	0.00	0.00
SUBTOTAL	323	94	1845	3991	728	328	0	0	0	0	0	0
TOTAL	7,309 lbs											

NOT USED

WIND ZONE												
AVE. HEIGHT												
AVE. WIDTH												
Ps	0.00	0.00	0.00	0.00	0.00	0.00	0.00	0.00	0.00	0.00	0.00	0.00
SUBTOTAL	0	0	0	0	0	0	0	0	0	0	0	0
TOTAL	0 lbs											

ρ CALCS:

2ND FLOOR CALCULATIONS:

Plate Height:	8.00 ft
Total length of Shearwall in Shortest Line:	11.00 ft
Length of Shortest Segment within Shear Line:	3.50 ft
Length of Longest Segment in Shear Line:	4.00 ft

Tributary Area:	1.0
Total Area:	2.0

ρ = 1.00  
ASCE 7-10 12.3.4.2 b

MAIN FLOOR CALCULATIONS:

Plate Height:	11.00 ft
Total length of Shearwall in Shortest Line:	6.00 ft
Length of Shortest Shearwall within Shear Line:	6.00 ft
Length of Longest Wall in Shear Line:	6.00 ft

Tributary Area:	21.5
Total Area:	74.0

ρ = 1.00  
ASCE 7-10 12.3.4.2 a

NOT USED:

Plate Height:	8.00 ft
Total length of Shearwall in Shortest Line:	8.00 ft
Length of Shortest Shearwall within Shear Line:	8.00 ft
Length of Longest Wall in Shear Line:	8.00 ft

Tributary Area:	1.0
Total Area:	2.0

ρ = NA



All loads in pounds per square foot

**SEISMIC DESIGN:**

$E = E_h + E_v$

$E = \rho Q_E + .2S_{DS}D$

$Q_E = V = C_s W$

WALL DEAD LOAD =	10 psf
FLAT ROOF SNOW LOAD =	25 psf
RED. S.L. (20%*S.L.) =	0

ROOF DEAD LOAD =	15.0 psf
UPPER FLOOR D.L. =	15.0 psf
LOWER FLOOR D.L. =	15.0 psf
FLOOR LIVE LOAD =	40.0 psf

$\rho =$	1.00
Site Class =	D
$I_E =$	1
R =	6.5
$h_n =$	30.25

When the Site Class is not specified by Geotech, D will be assumed  
Importance factor as defined in Table 11.5-1

Total height of structure

$V = 0.7S_{DS}I_E W / R$	$S_{DS} = 2/3 S_{MS}$	$S_s =$	145.1%	$S_{MS} = 145.1\%$	$V =$	0.104	W
$V_{max} = S_{D1}I_E W / T_g R$	$S_{MS} = (F_a)(S_s)$	$F_a =$	1.00	$S_{DS} = 96.7\%$	$E =$	0.104	W
$T_g = 0.02h_n^{0.75}$	$S_{D1} = 2/3 S_{M1}$	$S_1 =$	55.6%	$S_{M1} = 83.4\%$	$C_s =$	0.104	
$T_g = 0.26 s$	$S_{M1} = (F_v)(S_1)$	$F_v =$	1.50	$S_{D1} = 55.6\%$			

**2ND FLOOR DIAPHRAGM LOADING:**

W (ROOF) =

LENGTH	WIDTH	LOAD	TOTAL
72	43	15.0	46440
		15.0	0
		15.0	0
		15.0	0
		15.0	0
Area = 3096		Sub-Total= 46440	

W (FLOOR) =

LENGTH	WIDTH	LOAD	TOTAL
		15.0	0
		15.0	0
		15.0	0
		15.0	0
		15.0	0
Area = 0		Sub-Total= 0	

W (WALL) =

LENGTH	TRIB. HT.	LOAD	TOTAL
136	4	10.0	5440
62	4	10.0	2480
		10.0	0
		10.0	0
		10.0	0
Area = 792		Sub-Total= 7920	

TOTAL = 54360 lb

**1ST FLOOR DIAPHRAGM LOADING:**

W (ROOF) =

LENGTH	WIDTH	LOAD	TOTAL
10	56.5	15.0	8475
24	10.5	15.0	3780
46	8.5	15.0	5865
21	8	15.0	2520
		15.0	0
Area = 1376		Sub-Total= 20640	

W (FLOOR) =

LENGTH	WIDTH	LOAD	TOTAL
2400	1	15.0	36000
		15.0	0
		15.0	0
		15.0	0
		15.0	0
Area = 2400		Sub-Total= 36000	

W (WALL) =

LENGTH	TRIB. HT.	LOAD	TOTAL
136	4	10.0	5440
62	4	10.0	2480
148	5.5	10.0	8140
88	5.5	10.0	4840
		10.0	0
Area = 2090		Sub-Total= 20900	

TOTAL = 77540 lb

**NOT APPLICABLE**

W (ROOF) =

LENGTH	WIDTH	LOAD	TOTAL
		15.0	0
		15.0	0
		15.0	0
		15.0	0
		15.0	0
Area = 0		Sub-Total= 0	

W (FLOOR) =

LENGTH	WIDTH	LOAD	TOTAL
		15.0	0
		15.0	0
		15.0	0
		15.0	0
		15.0	0
Area = 0		Sub-Total= 0	

W (WALL) =

LENGTH	TRIB. HT.	LOAD	TOTAL
		10.0	0
		10.0	0
		10.0	0
		10.0	0
		10.0	0
Area = 0		Sub-Total= 0	

TOTAL = lb

V (2ND FLOOR) = .104 x 54360 lb = 5663 lbs  
 V (1ST FLOOR) = .104 x 77540 lb = 8078 lbs  
 V ( ) = .104 x lb = lbs

**REDISTRIBUTE:**

$\Sigma V \times \rho$	height	$\Sigma V \times \text{height}$
5663 lb	20	113258
8078 lb	11	88854
lb		0

TOTAL = 13741 lb                      TOTAL = 202113

E (2ND) =  $\frac{\Sigma V \times \text{height} \times \Sigma V \text{ TOTAL}}{\Sigma V \times \text{height TOTAL}}$  = 7700 lbs

E (1ST) =  $\frac{\Sigma V \times \text{height} \times \Sigma V \text{ TOTAL}}{\Sigma V \times \text{height TOTAL}}$  = 6041 lbs

E ( ) = NOT USED = 0 lbs



**SUMMARY:**

	WIND (front-rear)	WIND (left-right)	SEISMIC
ΣV (2ND) =	8440 lbs	7053 lbs	7700 lbs
ΣV (MAIN) =	8951 lbs	7309 lbs	6041 lbs
NOT APPLICABLE	0 lbs	0 lbs	0 lbs
TOTAL =	17391 lbs	14362 lbs	13741 lbs

**DIAPHRAGM SHEAR:**

Total diaphragm length =	74.0 ft	Sub-diaphragm length =	53.0 ft
Diaphragm width =	44.0 ft	ΣV (MAIN) =	8,951 lbs

$$v = \frac{\Sigma V(2nd)}{(2)(width)} = \frac{6411 \text{ lb}}{88 \text{ ft}} = 73 \text{ PLF}$$

IBC Table 2306.3.1 → 240 PLF

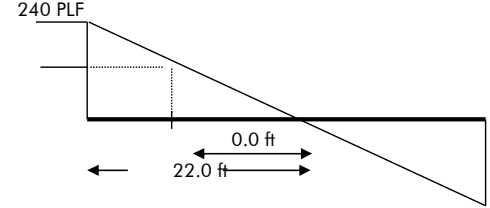

USE 15/32 CDX ROOF SHEATHING OR 3/4 T&G CDX SUBFLOORING w/8d AT 6 in o/c(PANEL EDGE), END 8d AT 12in o/c(PANEL FIELD)

**CHORD:**

Sub-diaphragm length =	53.0 ft	Total-diaphragm length =	74.0 ft
Sub-diaphragm width =	21.0 ft		

$$T = \frac{M}{B} = \frac{\Sigma V \times (\text{diaphragm length})}{8 \times (\text{diaphragm width})} = \frac{6411 \times 53 \text{ ft}}{8 \times 21 \text{ ft}} = 2022 \text{ lbs}$$

Top Plate Size: 2x6 Species/Grade: HF #2

Area = 8.25 in<sup>2</sup> F<sub>t</sub> = 525 psi  
 Load duration (C<sub>D</sub>) = 1.33 T<sub>allowable</sub> = Area x C<sub>D</sub> x F<sub>t</sub> = 5,761 lbs

Since T allowable is greater than T applied, OK.

SHEAR CAPACITY OF 10d COMMON NAIL = 102 lbs 102 x C<sub>d</sub> x p = 136 lbs 2015 NDS

$$\# \text{ OF NAILS PER 4 FT SPLICE} = \frac{2022 \text{ lbs}}{136 \text{ lbs}} = 15$$

USE 2x6 HF #2 TOP PLATE W/ (2) 10d NAILS @ 6 in O/C.

### Lateral Calculation Key

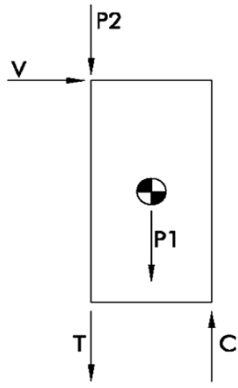

V = Shear, plf  
 H = Height of shearwall  
 L = Length of shearwall  
 P1 = Weight of shearwall and connected framing  
 P2 = Weight of adjacent wall

$T = V \times H - 0.5P1 - P2$  = Tension reaction to be resisted by holdown  
 $C = V \times H + 0.5P1$  = Compression reaction

### ASD Basic Load Combinations

For calculation of tension and compression forces in compliance with ASCE 7-10 2.4.1

#### Tension Equations (Uplift)

7.  $0.6D + W$

8.  $(0.6 - 0.14S_{Ds})D + E$   $\longrightarrow$   $0.46 D + E$

\*8.  $(0.6 - 0.14S_{Ds})D + 2.5 E$   $\longrightarrow$   $0.46 D + 2.5 E$

#### Compression Equations

5.  $D + W$

5.  $(1 + 0.14S_{Ds})D + E$   $\longrightarrow$   $1.14 D + E$

6.  $D + 0.75W + 0.75L + 0.75S$

6.  $(1.0 + 0.105S_{Ds})D + 0.75E + 0.75L + 0.75S$   $\longrightarrow$   $1.10 D + 0.75 E + 0.75 L + 0.75 S$

\*5.  $(1 + 0.14S_{Ds})D + 2.5E$   $\longrightarrow$   $1.14 D + 2.5 E$

\*6.  $(1.0 + 0.105S_{Ds})D + 1.875E + 0.75L + 0.75S$   $\longrightarrow$   $1.10 D + 1.875 E + 0.75 L + 0.75 S$

\* Equations include overstrength factor.

Note: The 0.7 factor for Earthquake loading has already been incorporated into the calculation of the lateral design force  $E_h$ , but not  $E_v$ . Therefore this factor has been omitted from equations 5, 6 and 8 where appropriate.



UPPER FLOOR REAR (MASTER SUITE)

SHEARWALL

WIND

SEISMIC

Floor Info

**Upper** Floor Level, e.g. Upper, Main, Lower  
**Lt-Rt** Load Direction, e.g. Left-Right, Front-Rear  
 (For Left Wall, Use Front-Rear Load Direction)

**CDX** Sheathing type  
 Values in accordance with AF&PA SDPWS-2015

**Roof** Resisting Dead Load  
 (e.g. Roof, Upper Floor, Main Floor)

**28.00 ft** Total Length of Shearwalls

V(from upper)= 7053 lb 7700 lb  
 V(from main)= 0 lb 0 lb  
 V(from lower)= 0 lb 0 lb  
 Σ (Wind) = 7,053 lb Σ (Smc) = 7,700 lb  
 v = 126 PLF v = 137 PLF

Tributary Width (Upper Floor)

1.0 tributary width  
 2.0 total width

Tributary Width (Main Floor)

1.0 tributary width  
 2.0 total width

Not Used

1.0 tributary width  
 2.0 total width

Height of Shearwall = 8.0 ft  
 Length of Shearwall = 6.5 ft

Aspect Ratio OK

Use alternate R factor for seismic? No

Tributary Area (Upper Floor)

1.0 tributary area  
 2.0 total area

Tributary Area (Main Floor)

1.0 tributary area  
 2.0 total area

Not Used

1.0 tributary area  
 2.0 total area

Weight of Shearwall = 10.0 lbs  
 Tributary width for dead load = 2.0 ft  
 Length of adjoining wall = 1.0 ft

SDPWS, Table 4.3A → 0.93 x 260 = 242 PLF

USE **SW6**

Seismic controls shearwall design

C<sub>TOTAL</sub> = (floor above) + (this floor) = + 1008 lbs = 1008 lbs Wind controls  
 T<sub>TOTAL</sub> = (floor above) + (this floor) = + 883 lbs = 883 lbs Load case 8 controls - Seismic

Seismic controls holdown design

Where overstrength factor is applicable, use this value for E in equations 5, 6, and 8: E = 1100 lbs

USE SIMPSON DESIGNED HOLDOWN: **CS14**  
 OR AT FOUNDATION / INTERIOR WALLS USE: **LSTHD8/RJ**

UPPER FLOOR FRONT (BEDROOMS/LAUN)

SHEARWALL

WIND

SEISMIC

Floor Info

**Upper** Floor Level, e.g. Upper, Main, Lower  
**Lt-Rt** Load Direction, e.g. Left-Right, Front-Rear  
 (For Left Wall, Use Front-Rear Load Direction)

**CDX** Sheathing type  
 Values in accordance with AF&PA SDPWS-2015

**Roof** Resisting Dead Load  
 (e.g. Roof, Upper Floor, Main Floor)

**28.00 ft** Total Length of Shearwalls

V(from upper)= 7053 lb 7700 lb  
 V(from main)= 0 lb 0 lb  
 V(from lower)= 0 lb 0 lb  
 Σ (Wind) = 7,053 lb Σ (Smc) = 7,700 lb  
 v = 126 PLF v = 137 PLF

Tributary Width (Upper Floor)

1.0 tributary width  
 2.0 total width

Tributary Width (Main Floor)

1.0 tributary width  
 2.0 total width

Not Used

1.0 tributary width  
 2.0 total width

Height of Shearwall = 8.0 ft  
 Length of Shearwall = 4.5 ft

Aspect Ratio OK

Use alternate R factor for seismic? No

Tributary Area (Upper Floor)

1.0 tributary area  
 2.0 total area

Tributary Area (Main Floor)

1.0 tributary area  
 2.0 total area

Not Used

1.0 tributary area  
 2.0 total area

Weight of Shearwall = 10.0 lbs  
 Tributary width for dead load = 2.0 ft  
 Length of adjoining wall = 2.0 ft

SDPWS, Table 4.3A → 0.93 x 260 = 242 PLF

USE **SW6**

Seismic controls shearwall design

C<sub>TOTAL</sub> = (floor above) + (this floor) = + 1008 lbs = 1008 lbs Wind controls  
 T<sub>TOTAL</sub> = (floor above) + (this floor) = + 883 lbs = 883 lbs Load case 8 controls - Seismic

Seismic controls holdown design

Where overstrength factor is applicable, use this value for E in equations 5, 6, and 8: E = 1100 lbs

USE SIMPSON DESIGNED HOLDOWN: **CS14**  
 OR AT FOUNDATION / INTERIOR WALLS USE: **LSTHD8/RJ**

UPPER FLOOR LEFT (BEDROOMS)

SHEARWALL

WIND

SEISMIC

Floor Info

**Upper** Floor Level, e.g. Upper, Main, Lower  
**Ft-Rr** Load Direction, e.g. Left-Right, Front-Rear  
 (For Left Wall, Use Front-Rear Load Direction)

**CDX** Sheathing type  
 Values in accordance with AF&PA SDPWS-2015

**Roof** Resisting Dead Load  
 (e.g. Roof, Upper Floor, Main Floor)

**32.00 ft** Total Length of Shearwalls

V(from upper)= 8440 lb 7700 lb  
 V(from main)= 0 lb 0 lb  
 V(from lower)= 0 lb 0 lb  
 Σ (Wind) = 8,440 lb Σ (Smc) = 7,700 lb  
 v = 132 PLF v = 120 PLF

Tributary Width (Upper Floor)

1.0 tributary width  
 2.0 total width

Tributary Width (Main Floor)

1.0 tributary width  
 2.0 total width

Not Used

1.0 tributary width  
 2.0 total width

Height of Shearwall = 8.0 ft  
 Length of Shearwall = 12.5 ft

Aspect Ratio OK

Use alternate R factor for seismic? No

Tributary Area (Upper Floor)

1.0 tributary area  
 2.0 total area

Tributary Area (Main Floor)

1.0 tributary area  
 2.0 total area

Not Used

1.0 tributary area  
 2.0 total area

Weight of Shearwall = 10.0 lbs  
 Tributary width for dead load = 6.0 ft  
 Length of adjoining wall = 2.0 ft

SDPWS, Table 4.3A → 0.93 x 260 = 242 PLF

USE **SW6**

Seismic controls shearwall design

C<sub>TOTAL</sub> = (floor above) + (this floor) = + 1055 lbs = 1055 lbs Wind controls  
 T<sub>TOTAL</sub> = (floor above) + (this floor) = + 311 lbs = 311 lbs Load case 8 controls - Seismic

Seismic controls holdown design

Where overstrength factor is applicable, use this value for E in equations 5, 6, and 8: E = 962 lbs

NO HOLDOWNS REQUIRED **OK**

UPPER FLOOR RIGHT (MASTER/LAUN)

SHEARWALL

WIND

SEISMIC

Floor Info

**Upper** Floor Level, e.g. Upper, Main, Lower  
**Fr-Rr** Load Direction, e.g. Left-Right, Front-Rear  
 (For Left Wall, Use Front-Rear Load Direction)

**CDX** Sheathing type  
 Values in accordance with AF&PA SDPWS-2015

**Roof** Resisting Dead Load  
 (e.g. Roof, Upper Floor, Main Floor)

**18.00 ft** Total Length of Shearwalls

V(from upper)= 8440 lb	7700 lb
V(from main)= 0 lb	0 lb
V(from lower)= 0 lb	0 lb
Σ (Wind) = 8,440 lb	Σ (Smc) = 7,700 lb
v = 234 PLF	v = 214 PLF

Tributary Width (Upper Floor)	
1.0	tributary width
2.0	total width
Tributary Width (Main Floor)	
1.0	tributary width
2.0	total width
Not Used	
1.0	tributary width
2.0	total width
Height of Shearwall = 8.0 ft	
Length of Shearwall = 4.0 ft	
Aspect Ratio OK	
Use alternate R factor for seismic? No	

Tributary Area (Upper Floor)	
1.0	tributary area
2.0	total area
Tributary Area (Main Floor)	
1.0	tributary area
2.0	total area
Not Used	
1.0	tributary area
2.0	total area
Weight of Shearwall = 10.0 lbs	
Tributary width for dead load = 12.0 ft	
Length of adjoining wall = 1.0 ft	

SDPWS, Table 4.3A → 0.93 x 260 = 242 PLF

USE **SW6**

*Seismic controls shearwall design*

$C_{TOTAL} =$  (floor above) + (this floor) =  + 1876 lbs = 1876 lbs Wind controls

$T_{TOTAL} =$  (floor above) + (this floor) =  + 1441 lbs = 1441 lbs Load case 8 controls - Wind

*Seismic controls holdown design*

Where overstrength factor is applicable, use this value for E in equations 5, 6, and 8: E = 1711 lbs

USE SIMPSON DESIGNED HOLDOWN: **CS14**  
 OR AT FOUNDATION / INTERIOR WALLS USE: **LSTHD8/RJ**

MAIN FLOOR REAR (PANTRY/DINING/LIVING)

SHEARWALL

WIND

SEISMIC

Floor Info

**Main** Floor Level, e.g. Upper, Main, Lower  
**Lt-Rt** Load Direction, e.g. Left-Right, Front-Rear  
 (For Left Wall, Use Front-Rear Load Direction)

**CDX** Sheathing type  
 Values in accordance with AF&PA SDPWS-2015

**U/FL** Resisting Dead Load  
 (e.g. Roof, Upper Floor, Main Floor)

**20.00 ft** Total Length of Shearwalls

V(from upper)= 7053 lb	7700 lb
V(from main)= 7309 lb	6041 lb
V(from lower)= 0 lb	0 lb
Σ (Wind) = 14,362 lb	Σ (Smc) = 13,741 lb
v = 317 PLF	v = 309 PLF

Tributary Width (Upper Floor)	
1.0	tributary width
2.0	total width
Tributary Width (Main Floor)	
20.0	tributary width
52.0	total width
Not Used	
1.0	tributary width
2.0	total width
Height of Shearwall = 11.0 ft	
Length of Shearwall = 6.0 ft	
Aspect Ratio OK	
Use alternate R factor for seismic? No	

Tributary Area (Upper Floor)	
1.0	tributary area
2.0	total area
Tributary Area (Main Floor)	
20.0	tributary area
52.0	total area
Not Used	
1.0	tributary area
2.0	total area
Weight of Shearwall = 10.0 lbs	
Tributary width for dead load = 2.0 ft	
Length of adjoining wall = 2.0 ft	

SDPWS, Table 4.3A → 0.93 x 380 = 353 PLF

USE **SW4**

*Seismic controls shearwall design*

$C_{TOTAL} =$  (floor above) + (this floor) =  1008 + 3486 lbs = 4494 lbs Wind controls

$T_{TOTAL} =$  (floor above) + (this floor) =  883 + 3070 lbs = 3953 lbs Load case 8 controls - Seismic

*Seismic controls holdown design*

Where overstrength factor is applicable, use this value for E in equations 5, 6, and 8: E = 3395 lbs

USE SIMPSON DESIGNED HOLDOWN: **MST60**  
 OR AT FOUNDATION / INTERIOR WALLS USE: **HDU8-SDS2.5**

MAIN FLOOR MID (AT GARAGE/PORCH)

SHEARWALL

WIND

SEISMIC

Floor Info

**Main** Floor Level, e.g. Upper, Main, Lower  
**Lt-Rt** Load Direction, e.g. Left-Right, Front-Rear  
 (For Left Wall, Use Front-Rear Load Direction)

**CDX** Sheathing type  
 Values in accordance with AF&PA SDPWS-2015

**U/FL** Resisting Dead Load  
 (e.g. Roof, Upper Floor, Main Floor)

**30.00 ft** Total Length of Shearwalls

V(from upper)= 7053 lb	7700 lb
V(from main)= 7309 lb	6041 lb
V(from lower)= 0 lb	0 lb
Σ (Wind) = 14,362 lb	Σ (Smc) = 13,741 lb
v = 122 PLF	v = 101 PLF

Tributary Width (Upper Floor)	
0.0	tributary width
2.0	total width
Tributary Width (Main Floor)	
1.0	tributary width
2.0	total width
Not Used	
1.0	tributary width
2.0	total width
Height of Shearwall = 11.0 ft	
Length of Shearwall = 14.0 ft	
Aspect Ratio OK	
Use alternate R factor for seismic? No	

Tributary Area (Upper Floor)	
0.0	tributary area
2.0	total area
Tributary Area (Main Floor)	
1.0	tributary area
2.0	total area
Not Used	
1.0	tributary area
2.0	total area
Weight of Shearwall = 10.0 lbs	
Tributary width for dead load = 1.3 ft	
Length of adjoining wall = 1.0 ft	

SDPWS, Table 4.3A → 0.93 x 260 = 242 PLF

USE **SW6**

*Seismic controls shearwall design*

$C_{TOTAL} =$  (floor above) + (this floor) =  + 1340 lbs = 1340 lbs Wind controls

$T_{TOTAL} =$  (floor above) + (this floor) =  + 716 lbs = 716 lbs Load case 8 controls - Wind

*Wind controls holdown design*

Where overstrength factor is applicable, use this value for E in equations 5, 6, and 8: E = 1107 lbs

USE SIMPSON DESIGNED HOLDOWN: **CS14**  
 OR AT FOUNDATION / INTERIOR WALLS USE: **LSTHD8/RJ**



MAIN FLOOR FRONT (AT GARAGE)

SHEARWALL

WIND

SEISMIC

<b>Floor Info</b>	
Main	Floor Level, e.g. Upper, Main, Lower
Lt-Rt	Load Direction, e.g. Left-Right, Front-Rear (For Left Wall, Use Front-Rear Load Direction)
CDX	Sheathing type Values in accordance with AF&PA SDPWS-2015
Roof	Resisting Dead Load (e.g. Roof, Upper Floor, Main Floor)
16.00 ft	Total Length of Shearwalls
V(from upper)= 7053 lb	7700 lb
V(from main)= 7309 lb	6041 lb
V(from lower)= 0 lb	0 lb
Σ (Wind) = 14,362 lb	Σ (Smc) = 13,741 lb
v = 335 PLF	v = 209 PLF

<b>Tributary Width (Upper Floor)</b>	
1.0	tributary width
2.0	total width
<b>Tributary Width (Main Floor)</b>	
13.0	tributary width
52.0	total width
Not Used	
1.0	tributary width
2.0	total width
Height of Shearwall = 7.0 ft	
Length of Shearwall = 2.0 ft	
Aspect Ratio OK	
Use alternate R factor for seismic? No	

<b>Tributary Area (Upper Floor)</b>	
31.0	tributary area
130.0	total area
<b>Tributary Area (Main Floor)</b>	
13.0	tributary area
52.0	total area
Not Used	
1.0	tributary area
2.0	total area
Weight of Shearwall = 10.0 lbs	
Tributary width for dead load = 2.0 ft	
Length of adjoining wall = 4.0 ft	

SDPWS, Table 4.3A → (2w/h) x 0.93 x 455 = 242 PLF

USE SW2  
USE SW3

Seismic controls shearwall design

C <sub>TOTAL</sub> =	(floor above) + (this floor) =		+ 2342 lbs	= 2342 lbs	Wind controls
T <sub>TOTAL</sub> =	(floor above) + (this floor) =		+ 2097 lbs	= 2097 lbs	Load case 8 controls - Wind

Wind controls holdown design

Where overstrength factor is applicable, use this value for E in equations 5, 6, and 8: E = 1464 lbs

USE SIMPSON DESIGNED HOLDOWN: CS14  
OR AT FOUNDATION / INTERIOR WALLS USE: STHD10/RJ

MAIN FLOOR FRONT (CLOS. BATH)

SHEARWALL

WIND

SEISMIC

<b>Floor Info</b>	
Main	Floor Level, e.g. Upper, Main, Lower
Lt-Rt	Load Direction, e.g. Left-Right, Front-Rear (For Left Wall, Use Front-Rear Load Direction)
CDX	Sheathing type Values in accordance with AF&PA SDPWS-2015
U/FL	Resisting Dead Load (e.g. Roof, Upper Floor, Main Floor)
16.00 ft	Total Length of Shearwalls
V(from upper)= 7053 lb	7700 lb
V(from main)= 7309 lb	6041 lb
V(from lower)= 0 lb	0 lb
Σ (Wind) = 14,362 lb	Σ (Smc) = 13,741 lb
v = 335 PLF	v = 335 PLF

<b>Tributary Width (Upper Floor)</b>	
1.0	tributary width
2.0	total width
<b>Tributary Width (Main Floor)</b>	
13.0	tributary width
52.0	total width
Not Used	
1.0	tributary width
2.0	total width
Height of Shearwall = 11.0 ft	
Length of Shearwall = 4.0 ft	
Aspect Ratio OK	
Use alternate R factor for seismic? No	

<b>Tributary Area (Upper Floor)</b>	
1.0	tributary area
2.0	total area
<b>Tributary Area (Main Floor)</b>	
13.0	tributary area
52.0	total area
Not Used	
1.0	tributary area
2.0	total area
Weight of Shearwall = 10.0 lbs	
Tributary width for dead load = 3.0 ft	
Length of adjoining wall = 1.0 ft	

SDPWS, Table 4.3A → (2w/h) x 0.93 x 595 = 402 PLF

USE SW2

Seismic controls shearwall design

C <sub>TOTAL</sub> =	(floor above) + (this floor) =		+ 3681 lbs	= 3681 lbs	Wind controls
T <sub>TOTAL</sub> =	(floor above) + (this floor) =		+ 3469 lbs	= 3469 lbs	Load case 8 controls - Seismic

Seismic controls holdown design

Where overstrength factor is applicable, use this value for E in equations 5, 6, and 8: E = 3685 lbs

USE SIMPSON DESIGNED HOLDOWN: MST60  
OR AT FOUNDATION / INTERIOR WALLS USE: STHD14/RJ

MAIN FLOOR LEFT (AT GARAGE/PANTRY)

SHEARWALL

WIND

SEISMIC

<b>Floor Info</b>	
Main	Floor Level, e.g. Upper, Main, Lower
Lt-Rt	Load Direction, e.g. Left-Right, Front-Rear (For Left Wall, Use Front-Rear Load Direction)
CDX	Sheathing type Values in accordance with AF&PA SDPWS-2015
U/FL	Resisting Dead Load (e.g. Roof, Upper Floor, Main Floor)
39.00 ft	Total Length of Shearwalls
V(from upper)= 8440 lb	7700 lb
V(from main)= 8951 lb	6041 lb
V(from lower)= 0 lb	0 lb
Σ (Wind) = 17,391 lb	Σ (Smc) = 13,741 lb
v = 158 PLF	v = 132 PLF

<b>Tributary Width (Upper Floor)</b>	
1.0	tributary width
2.0	total width
<b>Tributary Width (Main Floor)</b>	
16.0	tributary width
74.0	total width
Not Used	
1.0	tributary width
2.0	total width
Height of Shearwall = 11.0 ft	
Length of Shearwall = 16.0 ft	
Aspect Ratio OK	
Use alternate R factor for seismic? No	

<b>Tributary Area (Upper Floor)</b>	
1.0	tributary area
2.0	total area
<b>Tributary Area (Main Floor)</b>	
16.0	tributary area
74.0	total area
Not Used	
1.0	tributary area
2.0	total area
Weight of Shearwall = 10.0 lbs	
Tributary width for dead load = 1.3 ft	
Length of adjoining wall = 1.0 ft	

SDPWS, Table 4.3A → 0.93 x 260 = 242 PLF

USE SW6

Seismic controls shearwall design

C <sub>TOTAL</sub> =	(floor above) + (this floor) =		+ 1736 lbs	= 1736 lbs	Wind controls
T <sub>TOTAL</sub> =	(floor above) + (this floor) =		+ 1034 lbs	= 1034 lbs	Load case 8 controls - Wind

Wind controls holdown design

Where overstrength factor is applicable, use this value for E in equations 5, 6, and 8: E = 1454 lbs

USE SIMPSON DESIGNED HOLDOWN: CS14  
OR AT FOUNDATION / INTERIOR WALLS USE: LSTHD8/RJ

MAIN FLOOR MID 1 (GARAGE)

SHEARWALL

WIND

SEISMIC

Floor Info	
Main	Floor Level, e.g. Upper, Main, Lower
Ft-Rr	Load Direction, e.g. Left-Right, Front-Rear (For Left Wall, Use Front-Rear Load Direction)
CDX	Sheathing type Values in accordance with AF&PA SDPWS-2015
U/FL	Resisting Dead Load (e.g. Roof, Upper Floor, Main Floor)
18.00 ft	Total Length of Shearwalls
V(from upper)= 8440 lb	7700 lb
V(from main)= 8951 lb	6041 lb
V(from lower)= 0 lb	0 lb
Σ (Wind) = 17,391 lb	Σ (Smc) = 13,741 lb
v = 178 PLF	v = 120 PLF

Tributary Width (Upper Floor)	
0.0	tributary width
2.0	total width
Tributary Width (Main Floor)	
26.5	tributary width
74.0	total width
Not Used	
1.0	tributary width
2.0	total width
Height of Shearwall =	11.0 ft
Length of Shearwall =	18.0 ft

Tributary Area (Upper Floor)	
0.0	tributary area
2.0	total area
Tributary Area (Main Floor)	
26.5	tributary area
74.0	total area
Not Used	
1.0	tributary area
2.0	total area
Weight of Shearwall =	10.0 lbs
Tributary width for dead load =	1.0 ft
Length of adjoining wall =	0.0 ft

Use alternate R factor for seismic? **No**

SDPWS, Table 4.3A → 1.4 x 0.93 x 260 = 339 PLF

USE **SW6**

C <sub>TOTAL</sub> =	(floor above) + (this floor) =		+ 1959 lbs	= 1959 lbs	Wind controls
T <sub>TOTAL</sub> =	(floor above) + (this floor) =		+ 1284 lbs	= 1284 lbs	Load case 8 controls - Wind

Wind controls shearwall design

Wind controls holddown design

Where overstrength factor is applicable, use this value for E in equations 5, 6, and 8: E = 1322 lbs

USE SIMPSON DESIGNED HOLDDOWN: **CS14**  
OR AT FOUNDATION / INTERIOR WALLS USE: **LSTHD8/RJ**

MAIN FLOOR MID 2 (PDR/LIVING)

SHEARWALL

WIND

SEISMIC

Floor Info	
Main	Floor Level, e.g. Upper, Main, Lower
Ft-Rr	Load Direction, e.g. Left-Right, Front-Rear (For Left Wall, Use Front-Rear Load Direction)
CDX	Sheathing type Values in accordance with AF&PA SDPWS-2015
U/FL	Resisting Dead Load (e.g. Roof, Upper Floor, Main Floor)
9.00 ft	Total Length of Shearwalls
V(from upper)= 8440 lb	7700 lb
V(from main)= 8951 lb	6041 lb
V(from lower)= 0 lb	0 lb
Σ (Wind) = 17,391 lb	Σ (Smc) = 13,741 lb
v = 296 PLF	v = 200 PLF

Tributary Width (Upper Floor)	
0.0	tributary width
2.0	total width
Tributary Width (Main Floor)	
22.0	tributary width
74.0	total width
Not Used	
1.0	tributary width
2.0	total width
Height of Shearwall =	11.0 ft
Length of Shearwall =	3.0 ft

Tributary Area (Upper Floor)	
0.0	tributary area
2.0	total area
Tributary Area (Main Floor)	
22.0	tributary area
74.0	total area
Not Used	
1.0	tributary area
2.0	total area
Weight of Shearwall =	10.0 lbs
Tributary width for dead load =	1.0 ft
Length of adjoining wall =	1.0 ft

Warning! Height to Width Ratio!

Use alternate R factor for seismic? **No**

SDPWS, Table 4.3A → (2w/h) x 0.93 x 455 = 231 PLF

USE **SW3**

C <sub>TOTAL</sub> =	(floor above) + (this floor) =		+ 3252 lbs	= 3252 lbs	Wind controls
T <sub>TOTAL</sub> =	(floor above) + (this floor) =		+ 3065 lbs	= 3065 lbs	Load case 8 controls - Wind

Seismic controls shearwall design

Wind controls holddown design

Where overstrength factor is applicable, use this value for E in equations 5, 6, and 8: E = 2195 lbs

USE SIMPSON DESIGNED HOLDDOWN: **MST48**  
OR AT FOUNDATION / INTERIOR WALLS USE: **STHD14/RJ**

MAIN FLOOR RIGHT (AT PORCH/GUEST)

SHEARWALL

WIND

SEISMIC

Floor Info	
Main	Floor Level, e.g. Upper, Main, Lower
Ft-Rr	Load Direction, e.g. Left-Right, Front-Rear (For Left Wall, Use Front-Rear Load Direction)
CDX	Sheathing type Values in accordance with AF&PA SDPWS-2015
U/FL	Resisting Dead Load (e.g. Roof, Upper Floor, Main Floor)
8.00 ft	Total Length of Shearwalls
V(from upper)= 8440 lb	7700 lb
V(from main)= 8951 lb	6041 lb
V(from lower)= 0 lb	0 lb
Σ (Wind) = 17,391 lb	Σ (Smc) = 13,741 lb
v = 694 PLF	v = 593 PLF

Tributary Width (Upper Floor)	
1.0	tributary width
2.0	total width
Tributary Width (Main Floor)	
11.0	tributary width
74.0	total width
Not Used	
1.0	tributary width
2.0	total width
Height of Shearwall =	11.0 ft
Length of Shearwall =	8.0 ft

Tributary Area (Upper Floor)	
1.0	tributary area
2.0	total area
Tributary Area (Main Floor)	
11.0	tributary area
74.0	total area
Not Used	
1.0	tributary area
2.0	total area
Weight of Shearwall =	10.0 lbs
Tributary width for dead load =	5.0 ft
Length of adjoining wall =	3.0 ft

Aspect Ratio OK

Use alternate R factor for seismic? **No**

SDPWS, Table 4.3A → 0.93 x 700 = 651 PLF

USE **(2)SW4**

C <sub>TOTAL</sub> =	(floor above) + (this floor) =		+ 7632 lbs	= 7632 lbs	Wind controls
T <sub>TOTAL</sub> =	(floor above) + (this floor) =		+ 6855 lbs	= 6855 lbs	Load case 8 controls - Wind

Seismic controls shearwall design

Wind controls holddown design

Where overstrength factor is applicable, use this value for E in equations 5, 6, and 8: E = 6528 lbs

USE SIMPSON DESIGNED HOLDDOWN: **HDU11-SDS2.5**



**Wood Beam**

Lic. #: KW-06009431

**DESCRIPTION** Girder Truss #1 (Reactions Only)

**CODE REFERENCES**

Calculations per NDS 2015, IBC 2015, CBC 2016, ASCE 7-10  
 Load Combination Set : ASCE 7-16

**Material Properties**

Analysis Method	Allowable Stress Design	Fb +	2400 psi	E : Modulus of Elasticity	
Load Combination	ASCE 7-16	Fb -	1850 psi	Ebend- xx	1800ksi
Wood Species	DF/DF	Fc - Prll	1650 psi	Eminbend - x	950ksi
Wood Grade	24F - V4	Fc - Perp	650 psi	Ebend- yy	1600ksi
		Fv	265 psi	Eminbend - y	850ksi
		Ft	1100 psi	Density	31.21 pcf

Beam Bracing Beam is Fully Braced against lateral-torsional buckling

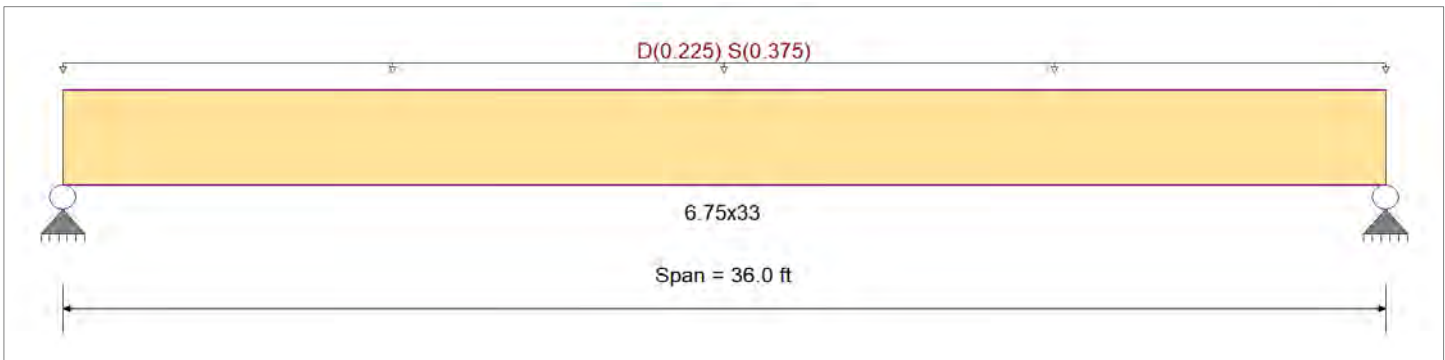

**Applied Loads**

Service loads entered. Load Factors will be applied for calculations.

Beam self weight calculated and added to loads

Uniform Load : D = 0.0150, S = 0.0250 ksf, Tributary Width = 15.0 ft, (ROOF)

**DESIGN SUMMARY**

**Design OK**

Maximum Bending Stress Ratio	=	<b>0.447</b> : 1	Maximum Shear Stress Ratio	=	<b>0.220</b> : 1
Section used for this span	=	<b>6.75x33</b>	Section used for this span	=	<b>6.75x33</b>
	=	1,028.67 psi		=	67.11 psi
	=	2,299.36 psi		=	304.75 psi
Load Combination	=	<b>+D+S+H</b>	Load Combination	=	<b>+D+S+H</b>
Location of maximum on span	=	18.000ft	Location of maximum on span	=	33.372 ft
Span # where maximum occurs	=	Span # 1	Span # where maximum occurs	=	Span # 1
<b>Maximum Deflection</b>					
Max Downward Transient Deflection		0.392 in	Ratio =		1102 >=360
Max Upward Transient Deflection		0.000 in	Ratio =		0 <360
Max Downward Total Deflection		0.677 in	Ratio =		637 >=240
Max Upward Total Deflection		0.000 in	Ratio =		0 <240

**Maximum Forces & Stresses for Load Combinations**

Load Combination	Segment Length	Span #	Max Stress Ratios									Moment Values			Shear Values							
			M	V	C <sub>d</sub>	C <sub>F/V</sub>	C <sub>i</sub>	C <sub>r</sub>	C <sub>m</sub>	C <sub>t</sub>	C <sub>L</sub>	M	fb	F'b	V	fv	F'v					
+D+H	Length = 36.0 ft	1	0.241	0.119	0.90	0.833	1.00	1.00	1.00	1.00	1.00	1.00	1.00	44.27	433.63	1799.50	0.00	0.00	0.00	4.20	28.29	238.50
+D+L+H	Length = 36.0 ft	1	0.217	0.107	1.00	0.833	1.00	1.00	1.00	1.00	1.00	1.00	1.00	44.27	433.63	1999.44	0.00	0.00	0.00	0.00	0.00	265.00
+D+Lr+H	Length = 36.0 ft	1	0.174	0.085	1.25	0.833	1.00	1.00	1.00	1.00	1.00	1.00	1.00	44.27	433.63	2499.30	0.00	0.00	0.00	4.20	28.29	331.25
+D+S+H	Length = 36.0 ft	1	0.447	0.220	1.15	0.833	1.00	1.00	1.00	1.00	1.00	1.00	1.00	105.02	1,028.67	2299.36	0.00	0.00	0.00	9.97	67.11	304.75
+D+0.750Lr+0.750L+H	Length = 36.0 ft	1	0.174	0.085	1.25	0.833	1.00	1.00	1.00	1.00	1.00	1.00	1.00	44.27	433.63	2499.30	0.00	0.00	0.00	4.20	28.29	331.25
+D+0.750L+0.750S+H	Length = 36.0 ft	1	0.383	0.188	1.15	0.833	1.00	1.00	1.00	1.00	1.00	1.00	1.00	89.83	879.91	2299.36	0.00	0.00	0.00	8.52	57.40	304.75
+D+0.60W+H						0.833	1.00	1.00	1.00	1.00	1.00	1.00				0.00			0.00	0.00	0.00	

**Wood Beam**

Lic. # : KW-06009431

**DESCRIPTIO Girder Truss #1 (Reactions Only)**

Load Combination	Segment Length	Span #	Max Stress Ratios								Moment Values			Shear Values		
			M	V	C <sub>d</sub>	C <sub>F/V</sub>	C <sub>i</sub>	C <sub>r</sub>	C <sub>m</sub>	C <sub>t</sub>	C <sub>L</sub>	M	fb	F'b	V	fv
Length = 36.0 ft	1	0.136	0.067	1.60	0.833	1.00	1.00	1.00	1.00	1.00	44.27	433.63	3199.11	4.20	28.29	424.00
+D+0.750Lr+0.750L+0.450W-					0.833	1.00	1.00	1.00	1.00	1.00			0.00	0.00	0.00	0.00
Length = 36.0 ft	1	0.136	0.067	1.60	0.833	1.00	1.00	1.00	1.00	1.00	44.27	433.63	3199.11	4.20	28.29	424.00
+D+0.750L+0.750S+0.450W+					0.833	1.00	1.00	1.00	1.00	1.00			0.00	0.00	0.00	0.00
Length = 36.0 ft	1	0.275	0.135	1.60	0.833	1.00	1.00	1.00	1.00	1.00	89.83	879.91	3199.11	8.52	57.40	424.00
+0.60D+0.60W+0.60H					0.833	1.00	1.00	1.00	1.00	1.00			0.00	0.00	0.00	0.00
Length = 36.0 ft	1	0.081	0.040	1.60	0.833	1.00	1.00	1.00	1.00	1.00	26.56	260.18	3199.11	2.52	16.97	424.00
+D+0.70E+0.60H					0.833	1.00	1.00	1.00	1.00	1.00			0.00	0.00	0.00	0.00
Length = 36.0 ft	1	0.136	0.067	1.60	0.833	1.00	1.00	1.00	1.00	1.00	44.27	433.63	3199.11	4.20	28.29	424.00
+D+0.750L+0.750S+0.5250E-					0.833	1.00	1.00	1.00	1.00	1.00			0.00	0.00	0.00	0.00
Length = 36.0 ft	1	0.275	0.135	1.60	0.833	1.00	1.00	1.00	1.00	1.00	89.83	879.91	3199.11	8.52	57.40	424.00
+0.60D+0.70E+H					0.833	1.00	1.00	1.00	1.00	1.00			0.00	0.00	0.00	0.00
Length = 36.0 ft	1	0.081	0.040	1.60	0.833	1.00	1.00	1.00	1.00	1.00	26.56	260.18	3199.11	2.52	16.97	424.00

**Overall Maximum Deflections**

Load Combination	Span	Max. "-" Defl	Location in Span	Load Combination	Max. "+" Defl	Location in Span
+D+S+H	1	0.6772	18.131		0.0000	0.000

**Vertical Reactions**

Support notation : Far left is #'

Values in KIPS

Load Combination	Support 1	Support 2
Overall MAXimum	11.669	11.669
Overall MINimum	6.750	6.750
+D+H	4.919	4.919
+D+L+H	4.919	4.919
+D+Lr+H	4.919	4.919
+D+S+H	11.669	11.669
+D+0.750Lr+0.750L+H	4.919	4.919
+D+0.750L+0.750S+H	9.982	9.982
+D+0.60W+H	4.919	4.919
+D+0.750Lr+0.750L+0.450W+H	4.919	4.919
+D+0.750L+0.750S+0.450W+H	9.982	9.982
+0.60D+0.60W+0.60H	2.951	2.951
+D+0.70E+0.60H	4.919	4.919
+D+0.750L+0.750S+0.5250E+H	9.982	9.982
+0.60D+0.70E+H	2.951	2.951
D Only	4.919	4.919
Lr Only		
L Only		
S Only	6.750	6.750
W Only		
E Only		
H Only		



## Wood Beam

Lic. #: KW-06009431

### DESCRIPTION Girder Truss #2 (Reactions Only)

### CODE REFERENCES

Calculations per NDS 2015, IBC 2015, CBC 2016, ASCE 7-10  
Load Combination Set : ASCE 7-16

### Material Properties

Analysis Method	Allowable Stress Design	Fb +	2,400.0 psi	E : Modulus of Elasticity	
Load Combination	ASCE 7-16	Fb -	1,850.0 psi	Ebend- xx	1,800.0 ksi
Wood Species	DF/DF	Fc - Prll	1,650.0 psi	Eminbend - x	950.0 ksi
Wood Grade	24F - V4	Fc - Perp	650.0 psi	Ebend- yy	1,600.0 ksi
		Fv	265.0 psi	Eminbend - y	850.0 ksi
		Ft	1,100.0 psi	Density	31.210 pcf
Beam Bracing	Beam is Fully Braced against lateral-torsional buckling				

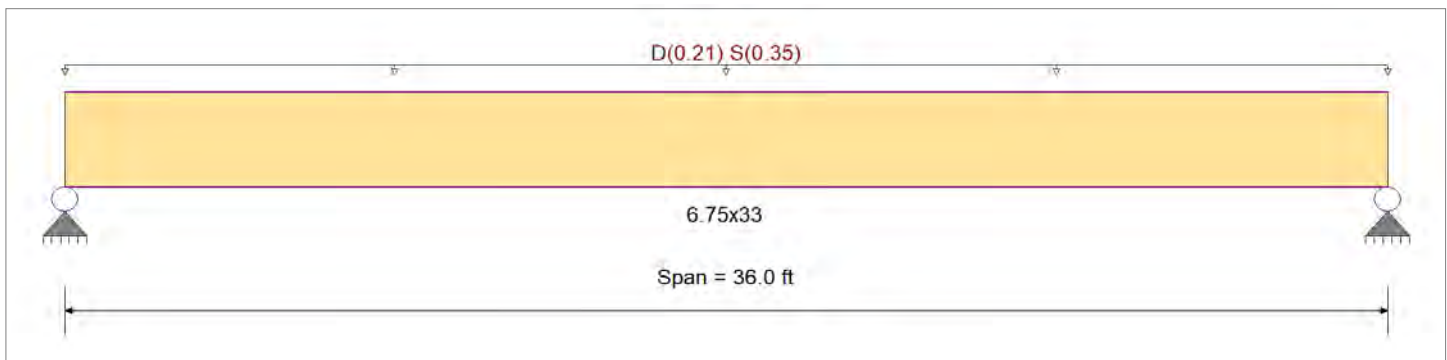

### Applied Loads

Service loads entered. Load Factors will be applied for calculations.

Beam self weight calculated and added to loads

Uniform Load : D = 0.0150, S = 0.0250 ksf, Tributary Width = 14.0 ft, (ROOF)

### DESIGN SUMMARY

**Design OK**

Maximum Bending Stress Ratio	=	<b>0.420</b> : 1	Maximum Shear Stress Ratio	=	<b>0.207</b> : 1
Section used for this span	=	<b>6.75x33</b>	Section used for this span	=	<b>6.75x33</b>
	=	965.20 psi		=	62.97 psi
	=	2,299.36 psi		=	304.75 psi
Load Combination	=	<b>+D+S+H</b>	Load Combination	=	<b>+D+S+H</b>
Location of maximum on span	=	18.000 ft	Location of maximum on span	=	33.372 ft
Span # where maximum occurs	=	Span # 1	Span # where maximum occurs	=	Span # 1
<b>Maximum Deflection</b>					
Max Downward Transient Deflection		0.366 in	Ratio =		<b>1181</b> >=360
Max Upward Transient Deflection		0.000 in	Ratio =		<b>0</b> <360
Max Downward Total Deflection		0.635 in	Ratio =		<b>679</b> >=240
Max Upward Total Deflection		0.000 in	Ratio =		<b>0</b> <240

### Maximum Forces & Stresses for Load Combinations

Load Combination	Segment Length	Span #	Max Stress Ratios									Moment Values			Shear Values									
			M	V	C <sub>d</sub>	C <sub>F/V</sub>	C <sub>i</sub>	C <sub>r</sub>	C <sub>m</sub>	C <sub>t</sub>	C <sub>L</sub>	M	fb	F'b	V	fv	F'v							
+D+H	Length = 36.0 ft	1	0.228	0.112	0.90	0.833	1.00	1.00	1.00	1.00	1.00	1.00	1.00	1.00	41.84	409.83	1799.50	0.00	0.00	0.00	3.97	26.74	238.50	
+D+L+H	Length = 36.0 ft	1	0.205	0.101	1.00	0.833	1.00	1.00	1.00	1.00	1.00	1.00	1.00	1.00	41.84	409.83	1999.44	0.00	0.00	0.00	0.00	0.00	0.00	265.00
+D+Lr+H	Length = 36.0 ft	1	0.164	0.081	1.25	0.833	1.00	1.00	1.00	1.00	1.00	1.00	1.00	1.00	41.84	409.83	2499.30	0.00	0.00	0.00	3.97	26.74	331.25	
+D+S+H	Length = 36.0 ft	1	0.420	0.207	1.15	0.833	1.00	1.00	1.00	1.00	1.00	1.00	1.00	1.00	98.54	965.20	2299.36	0.00	0.00	0.00	9.35	62.97	304.75	
+D+0.750Lr+0.750L+H	Length = 36.0 ft	1	0.164	0.081	1.25	0.833	1.00	1.00	1.00	1.00	1.00	1.00	1.00	1.00	41.84	409.83	2499.30	0.00	0.00	0.00	3.97	26.74	331.25	
+D+0.750L+0.750S+H	Length = 36.0 ft	1	0.359	0.177	1.15	0.833	1.00	1.00	1.00	1.00	1.00	1.00	1.00	1.00	84.37	826.36	2299.36	0.00	0.00	0.00	8.01	53.91	304.75	
+D+0.60W+H						0.833	1.00	1.00	1.00	1.00	1.00	1.00	1.00				0.00	0.00	0.00	0.00	0.00	0.00	0.00	

**Wood Beam**

Lic. # : KW-06009431

**DESCRIPTIO Girder Truss #2 (Reactions Only)**

Load Combination	Segment Length	Span #	Max Stress Ratios									Moment Values			Shear Values		
			M	V	C <sub>d</sub>	C <sub>F/V</sub>	C <sub>i</sub>	C <sub>r</sub>	C <sub>m</sub>	C <sub>t</sub>	C <sub>L</sub>	M	fb	F'b	V	fv	F'v
Length = 36.0 ft	1	0.128	0.063	1.60	0.833	1.00	1.00	1.00	1.00	1.00	1.00	41.84	409.83	3199.11	3.97	26.74	424.00
+D+0.750Lr+0.750L+0.450W-					0.833	1.00	1.00	1.00	1.00	1.00	1.00			0.00	0.00	0.00	0.00
Length = 36.0 ft	1	0.128	0.063	1.60	0.833	1.00	1.00	1.00	1.00	1.00	1.00	41.84	409.83	3199.11	3.97	26.74	424.00
+D+0.750L+0.750S+0.450W+					0.833	1.00	1.00	1.00	1.00	1.00	1.00			0.00	0.00	0.00	0.00
Length = 36.0 ft	1	0.258	0.127	1.60	0.833	1.00	1.00	1.00	1.00	1.00	1.00	84.37	826.36	3199.11	8.01	53.91	424.00
+0.60D+0.60W+0.60H					0.833	1.00	1.00	1.00	1.00	1.00	1.00			0.00	0.00	0.00	0.00
Length = 36.0 ft	1	0.077	0.038	1.60	0.833	1.00	1.00	1.00	1.00	1.00	1.00	25.10	245.90	3199.11	2.38	16.04	424.00
+D+0.70E+0.60H					0.833	1.00	1.00	1.00	1.00	1.00	1.00			0.00	0.00	0.00	0.00
Length = 36.0 ft	1	0.128	0.063	1.60	0.833	1.00	1.00	1.00	1.00	1.00	1.00	41.84	409.83	3199.11	3.97	26.74	424.00
+D+0.750L+0.750S+0.5250E-					0.833	1.00	1.00	1.00	1.00	1.00	1.00			0.00	0.00	0.00	0.00
Length = 36.0 ft	1	0.258	0.127	1.60	0.833	1.00	1.00	1.00	1.00	1.00	1.00	84.37	826.36	3199.11	8.01	53.91	424.00
+0.60D+0.70E+H					0.833	1.00	1.00	1.00	1.00	1.00	1.00			0.00	0.00	0.00	0.00
Length = 36.0 ft	1	0.077	0.038	1.60	0.833	1.00	1.00	1.00	1.00	1.00	1.00	25.10	245.90	3199.11	2.38	16.04	424.00

**Overall Maximum Deflections**

Load Combination	Span	Max. "-" Defl	Location in Span	Load Combination	Max. "+" Defl	Location in Span
+D+S+H	1	0.6355	18.131		0.0000	0.000

**Vertical Reactions**

Support notation : Far left is #'

Values in KIPS

Load Combination	Support 1	Support 2
Overall MAXimum	10.949	10.949
Overall MINimum	6.300	6.300
+D+H	4.649	4.649
+D+L+H	4.649	4.649
+D+Lr+H	4.649	4.649
+D+S+H	10.949	10.949
+D+0.750Lr+0.750L+H	4.649	4.649
+D+0.750L+0.750S+H	9.374	9.374
+D+0.60W+H	4.649	4.649
+D+0.750Lr+0.750L+0.450W+H	4.649	4.649
+D+0.750L+0.750S+0.450W+H	9.374	9.374
+0.60D+0.60W+0.60H	2.789	2.789
+D+0.70E+0.60H	4.649	4.649
+D+0.750L+0.750S+0.5250E+H	9.374	9.374
+0.60D+0.70E+H	2.789	2.789
D Only	4.649	4.649
Lr Only		
L Only		
S Only	6.300	6.300
W Only		
E Only		
H Only		



## Wood Beam

Lic. #: KW-06009431

### DESCRIPTION Girder Truss #3 (Reactions Only)

### CODE REFERENCES

Calculations per NDS 2015, IBC 2015, CBC 2016, ASCE 7-10  
Load Combination Set : ASCE 7-16

### Material Properties

Analysis Method	Allowable Stress Design	Fb +	2,400.0 psi	E : Modulus of Elasticity	
Load Combination	ASCE 7-16	Fb -	1,850.0 psi	Ebend- xx	1,800.0ksi
Wood Species	DF/DF	Fc - Prll	1,650.0 psi	Eminbend - x	950.0ksi
Wood Grade	24F - V4	Fc - Perp	650.0 psi	Ebend- yy	1,600.0ksi
		Fv	265.0 psi	Eminbend - y	850.0ksi
		Ft	1,100.0 psi	Density	31.210pcf
Beam Bracing	Beam is Fully Braced against lateral-torsional buckling				

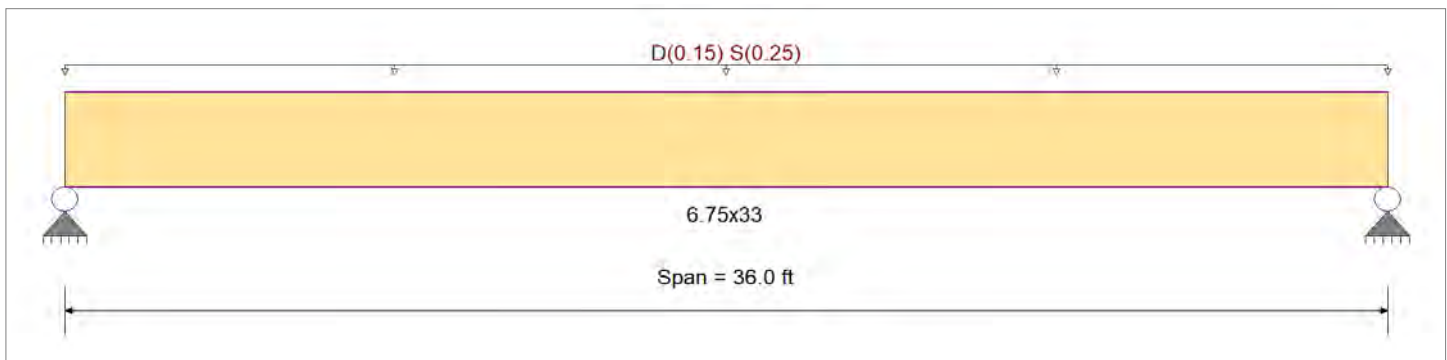

### Applied Loads

Service loads entered. Load Factors will be applied for calculations.

Beam self weight calculated and added to loads

Uniform Load : D = 0.0150, S = 0.0250 ksf, Tributary Width = 10.0 ft, (ROOF)

### DESIGN SUMMARY

**Design OK**

Maximum Bending Stress Ratio	=	<b>0.309</b> < 1	Maximum Shear Stress Ratio	=	<b>0.152</b> < 1
Section used for this span	=	<b>6.75x33</b>	Section used for this span	=	<b>6.75x33</b>
	=	711.32psi		=	46.40 psi
	=	2,299.36psi		=	304.75 psi
Load Combination	=	+D+S+H	Load Combination	=	+D+S+H
Location of maximum on span	=	18.000ft	Location of maximum on span	=	33.372 ft
Span # where maximum occurs	=	Span # 1	Span # where maximum occurs	=	Span # 1
<b>Maximum Deflection</b>					
Max Downward Transient Deflection		0.261 in	Ratio =		1654 >=360
Max Upward Transient Deflection		0.000 in	Ratio =		0 <360
Max Downward Total Deflection		0.468 in	Ratio =		922 >=240
Max Upward Total Deflection		0.000 in	Ratio =		0 <240

### Maximum Forces & Stresses for Load Combinations

Load Combination	Segment Length	Span #	Max Stress Ratios									Moment Values			Shear Values								
			M	V	C <sub>d</sub>	C <sub>F/V</sub>	C <sub>i</sub>	C <sub>r</sub>	C <sub>m</sub>	C <sub>t</sub>	C <sub>L</sub>	M	fb	F'b	V	fv	F'v						
+D+H	Length = 36.0 ft	1	0.175	0.086	0.90	0.833	1.00	1.00	1.00	1.00	1.00	1.00	1.00	32.12	314.62	1799.50	0.00	0.00	0.00	3.05	20.53	238.50	
+D+L+H	Length = 36.0 ft	1	0.157	0.077	1.00	0.833	1.00	1.00	1.00	1.00	1.00	1.00	1.00	32.12	314.62	1999.44	0.00	0.00	0.00	0.00	0.00	0.00	265.00
+D+Lr+H	Length = 36.0 ft	1	0.126	0.062	1.25	0.833	1.00	1.00	1.00	1.00	1.00	1.00	1.00	32.12	314.62	2499.30	0.00	0.00	0.00	0.00	0.00	0.00	331.25
+D+S+H	Length = 36.0 ft	1	0.309	0.152	1.15	0.833	1.00	1.00	1.00	1.00	1.00	1.00	1.00	72.62	711.32	2299.36	0.00	0.00	0.00	6.89	46.40	304.75	
+D+0.750Lr+0.750L+H	Length = 36.0 ft	1	0.126	0.062	1.25	0.833	1.00	1.00	1.00	1.00	1.00	1.00	1.00	32.12	314.62	2499.30	0.00	0.00	0.00	0.00	0.00	0.00	331.25
+D+0.750L+0.750S+H	Length = 36.0 ft	1	0.266	0.131	1.15	0.833	1.00	1.00	1.00	1.00	1.00	1.00	1.00	62.50	612.14	2299.36	0.00	0.00	0.00	5.93	39.93	304.75	
+D+0.60W+H						0.833	1.00	1.00	1.00	1.00	1.00	1.00	1.00			0.00			0.00	0.00	0.00	0.00	

**Wood Beam**

Lic. # : KW-06009431

**DESCRIPTIO Girder Truss #3 (Reactions Only)**

Load Combination	Segment Length	Span #	Max Stress Ratios								Moment Values			Shear Values		
			M	V	C <sub>d</sub>	C <sub>F/V</sub>	C <sub>i</sub>	C <sub>r</sub>	C <sub>m</sub>	C <sub>t</sub>	C <sub>L</sub>	M	fb	F'b	V	fv
Length = 36.0 ft	1	0.098	0.048	1.60	0.833	1.00	1.00	1.00	1.00	1.00	32.12	314.62	3199.11	3.05	20.53	424.00
+D+0.750Lr+0.750L+0.450W-					0.833	1.00	1.00	1.00	1.00	1.00			0.00	0.00	0.00	0.00
Length = 36.0 ft	1	0.098	0.048	1.60	0.833	1.00	1.00	1.00	1.00	1.00	32.12	314.62	3199.11	3.05	20.53	424.00
+D+0.750L+0.750S+0.450W+					0.833	1.00	1.00	1.00	1.00	1.00			0.00	0.00	0.00	0.00
Length = 36.0 ft	1	0.191	0.094	1.60	0.833	1.00	1.00	1.00	1.00	1.00	62.50	612.14	3199.11	5.93	39.93	424.00
+0.60D+0.60W+0.60H					0.833	1.00	1.00	1.00	1.00	1.00			0.00	0.00	0.00	0.00
Length = 36.0 ft	1	0.059	0.029	1.60	0.833	1.00	1.00	1.00	1.00	1.00	19.27	188.77	3199.11	1.83	12.32	424.00
+D+0.70E+0.60H					0.833	1.00	1.00	1.00	1.00	1.00			0.00	0.00	0.00	0.00
Length = 36.0 ft	1	0.098	0.048	1.60	0.833	1.00	1.00	1.00	1.00	1.00	32.12	314.62	3199.11	3.05	20.53	424.00
+D+0.750L+0.750S+0.5250E-					0.833	1.00	1.00	1.00	1.00	1.00			0.00	0.00	0.00	0.00
Length = 36.0 ft	1	0.191	0.094	1.60	0.833	1.00	1.00	1.00	1.00	1.00	62.50	612.14	3199.11	5.93	39.93	424.00
+0.60D+0.70E+H					0.833	1.00	1.00	1.00	1.00	1.00			0.00	0.00	0.00	0.00
Length = 36.0 ft	1	0.059	0.029	1.60	0.833	1.00	1.00	1.00	1.00	1.00	19.27	188.77	3199.11	1.83	12.32	424.00

**Overall Maximum Deflections**

Load Combination	Span	Max. "-" Defl	Location in Span	Load Combination	Max. "+" Defl	Location in Span
+D+S+H	1	0.4683	18.131		0.0000	0.000

**Vertical Reactions**

Support notation : Far left is #'

Values in KIPS

Load Combination	Support 1	Support 2
Overall MAXimum	8.069	8.069
Overall MINimum	4.500	4.500
+D+H	3.569	3.569
+D+L+H	3.569	3.569
+D+Lr+H	3.569	3.569
+D+S+H	8.069	8.069
+D+0.750Lr+0.750L+H	3.569	3.569
+D+0.750L+0.750S+H	6.944	6.944
+D+0.60W+H	3.569	3.569
+D+0.750Lr+0.750L+0.450W+H	3.569	3.569
+D+0.750L+0.750S+0.450W+H	6.944	6.944
+0.60D+0.60W+0.60H	2.141	2.141
+D+0.70E+0.60H	3.569	3.569
+D+0.750L+0.750S+0.5250E+H	6.944	6.944
+0.60D+0.70E+H	2.141	2.141
D Only	3.569	3.569
Lr Only		
L Only		
S Only	4.500	4.500
W Only		
E Only		
H Only		



**Wood Beam**

Lic. # : KW-06009431

**DESCRIPTIO HDR#1**

**CODE REFERENCES**

Calculations per NDS 2015, IBC 2015, CBC 2016, ASCE 7-10  
 Load Combination Set : ASCE 7-16

**Material Properties**

Analysis Method	Allowable Stress Design	Fb +	850 psi	E : Modulus of Elasticity	
Load Combination	ASCE 7-16	Fb -	850 psi	Ebend- xx	1300ksi
		Fc - Prll	1300 psi	Eminbend - x	470ksi
Wood Species	Hem Fir	Fc - Perp	405 psi		
Wood Grade	No.2	Fv	150 psi		
		Ft	525 psi	Density	26.84pcf
Beam Bracing	Beam is Fully Braced against lateral-torsional buckling				

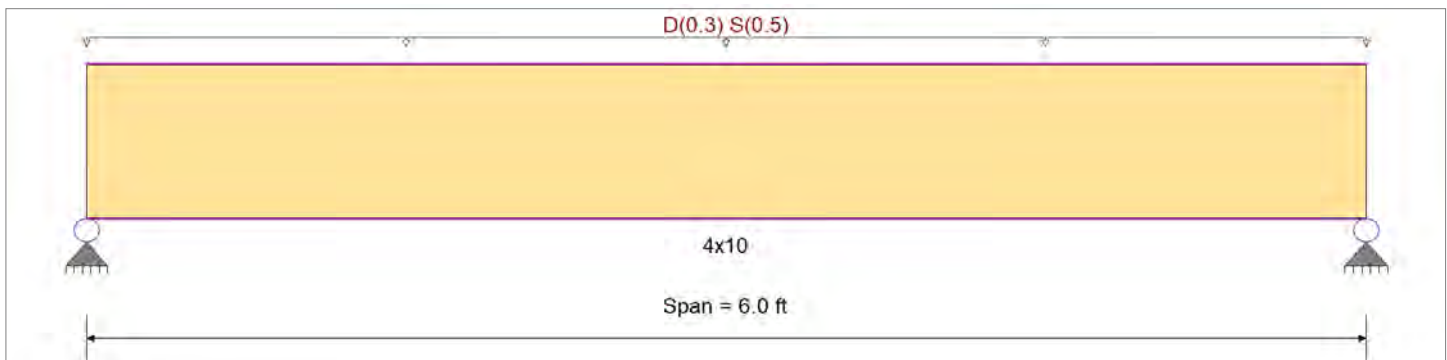

**Applied Loads**

Service loads entered. Load Factors will be applied for calculations.

Beam self weight calculated and added to loads

Uniform Load : D = 0.0150, S = 0.0250 ksf, Tributary Width = 20.0 ft, (ROOF)

**DESIGN SUMMARY**

**Design OK**

Maximum Bending Stress Ratio	=	<b>0.743</b> < 1	Maximum Shear Stress Ratio	=	<b>0.484</b> < 1
Section used for this span	=	<b>4x10</b>	Section used for this span	=	<b>4x10</b>
	=	872.06psi		=	83.41 psi
	=	1,173.00psi		=	172.50 psi
Load Combination	=	<b>+D+S+H</b>	Load Combination	=	<b>+D+S+H</b>
Location of maximum on span	=	<b>3.000ft</b>	Location of maximum on span	=	<b>0.000ft</b>
Span # where maximum occurs	=	<b>Span # 1</b>	Span # where maximum occurs	=	<b>Span # 1</b>
<b>Maximum Deflection</b>					
Max Downward Transient Deflection		<b>0.049</b> in	Ratio =	<b>1473</b> >= 360	
Max Upward Transient Deflection		<b>0.000</b> in	Ratio =	<b>0</b> < 360	
Max Downward Total Deflection		<b>0.079</b> in	Ratio =	<b>913</b> >= 240	
Max Upward Total Deflection		<b>0.000</b> in	Ratio =	<b>0</b> < 240	

**Maximum Forces & Stresses for Load Combinations**

Load Combination	Segment Length	Span #	Max Stress Ratios										Moment Values			Shear Values				
			M	V	C <sub>d</sub>	C <sub>F/V</sub>	C <sub>i</sub>	C <sub>r</sub>	C <sub>m</sub>	C <sub>t</sub>	C <sub>L</sub>	M	fb	F'b	V	fv	F'v			
+D+H	Length = 6.0 ft	1	0.361	0.235	0.90	1.200	1.00	1.00	1.00	1.00	1.00	1.38	331.10	918.00	0.00	0.00	0.00	0.68	31.67	135.00
+D+L+H	Length = 6.0 ft	1	0.325	0.211	1.00	1.200	1.00	1.00	1.00	1.00	1.00	1.38	331.10	1020.00	0.00	0.00	0.00	0.68	31.67	150.00
+D+Lr+H	Length = 6.0 ft	1	0.260	0.169	1.25	1.200	1.00	1.00	1.00	1.00	1.00	1.38	331.10	1275.00	0.00	0.00	0.00	0.68	31.67	187.50
+D+S+H	Length = 6.0 ft	1	0.743	0.484	1.15	1.200	1.00	1.00	1.00	1.00	1.00	3.63	872.06	1173.00	0.00	0.00	0.00	1.80	83.41	172.50
+D+0.750Lr+0.750L+H	Length = 6.0 ft	1	0.260	0.169	1.25	1.200	1.00	1.00	1.00	1.00	1.00	1.38	331.10	1275.00	0.00	0.00	0.00	0.68	31.67	187.50
+D+0.750L+0.750S+H	Length = 6.0 ft	1	0.628	0.409	1.15	1.200	1.00	1.00	1.00	1.00	1.00	3.06	736.82	1173.00	0.00	0.00	0.00	1.52	70.48	172.50
+D+0.60W+H						1.200	1.00	1.00	1.00	1.00	1.00			0.00	0.00	0.00	0.00	0.00	0.00	

**Wood Beam**

Lic. # : KW-06009431

**DESCRIPTIO HDR#1**

Load Combination	Segment Length	Span #	Max Stress Ratios									Moment Values			Shear Values		
			M	V	C <sub>d</sub>	C <sub>F/V</sub>	C <sub>i</sub>	C <sub>r</sub>	C <sub>m</sub>	C <sub>t</sub>	C <sub>L</sub>	M	fb	F'b	V	fv	Fv
Length = 6.0 ft	1	0.203	0.132	1.60	1.200	1.00	1.00	1.00	1.00	1.00	1.00	1.38	331.10	1632.00	0.68	31.67	240.00
+D+0.750Lr+0.750L+0.450W-					1.200	1.00	1.00	1.00	1.00	1.00	1.00			0.00	0.00	0.00	0.00
Length = 6.0 ft	1	0.203	0.132	1.60	1.200	1.00	1.00	1.00	1.00	1.00	1.00	1.38	331.10	1632.00	0.68	31.67	240.00
+D+0.750L+0.750S+0.450W+					1.200	1.00	1.00	1.00	1.00	1.00	1.00			0.00	0.00	0.00	0.00
Length = 6.0 ft	1	0.451	0.294	1.60	1.200	1.00	1.00	1.00	1.00	1.00	1.00	3.06	736.82	1632.00	1.52	70.48	240.00
+0.60D+0.60W+0.60H					1.200	1.00	1.00	1.00	1.00	1.00	1.00			0.00	0.00	0.00	0.00
Length = 6.0 ft	1	0.122	0.079	1.60	1.200	1.00	1.00	1.00	1.00	1.00	1.00	0.83	198.66	1632.00	0.41	19.00	240.00
+D+0.70E+0.60H					1.200	1.00	1.00	1.00	1.00	1.00	1.00			0.00	0.00	0.00	0.00
Length = 6.0 ft	1	0.203	0.132	1.60	1.200	1.00	1.00	1.00	1.00	1.00	1.00	1.38	331.10	1632.00	0.68	31.67	240.00
+D+0.750L+0.750S+0.5250E-					1.200	1.00	1.00	1.00	1.00	1.00	1.00			0.00	0.00	0.00	0.00
Length = 6.0 ft	1	0.451	0.294	1.60	1.200	1.00	1.00	1.00	1.00	1.00	1.00	3.06	736.82	1632.00	1.52	70.48	240.00
+0.60D+0.70E+H					1.200	1.00	1.00	1.00	1.00	1.00	1.00			0.00	0.00	0.00	0.00
Length = 6.0 ft	1	0.122	0.079	1.60	1.200	1.00	1.00	1.00	1.00	1.00	1.00	0.83	198.66	1632.00	0.41	19.00	240.00

**Overall Maximum Deflections**

Load Combination	Span	Max. "-" Defl	Location in Span	Load Combination	Max. "+" Defl	Location in Span
+D+S+H	1	0.0788	3.022		0.0000	0.000

**Vertical Reactions**

Support notation : Far left is #'

Values in KIPS

Load Combination	Support 1	Support 2
Overall MAXimum	2.418	2.418
Overall MINimum	1.500	1.500
+D+H	0.918	0.918
+D+L+H	0.918	0.918
+D+Lr+H	0.918	0.918
+D+S+H	2.418	2.418
+D+0.750Lr+0.750L+H	0.918	0.918
+D+0.750L+0.750S+H	2.043	2.043
+D+0.60W+H	0.918	0.918
+D+0.750Lr+0.750L+0.450W+H	0.918	0.918
+D+0.750L+0.750S+0.450W+H	2.043	2.043
+0.60D+0.60W+0.60H	0.551	0.551
+D+0.70E+0.60H	0.918	0.918
+D+0.750L+0.750S+0.5250E+H	2.043	2.043
+0.60D+0.70E+H	0.551	0.551
D Only	0.918	0.918
Lr Only		
L Only		
S Only	1.500	1.500
W Only		
E Only		
H Only		



## Wood Beam

Lic. # : KW-06009431

### DESCRIPTION HDR#2

### CODE REFERENCES

Calculations per NDS 2015, IBC 2015, CBC 2016, ASCE 7-10  
Load Combination Set : ASCE 7-16

### Material Properties

Analysis Method	Allowable Stress Design	Fb +	850.0 psi	E : Modulus of Elasticity	
Load Combination	ASCE 7-16	Fb -	850.0 psi	Ebend- xx	1,300.0ksi
		Fc - Prll	1,300.0 psi	Eminbend - x	470.0ksi
Wood Species	Hem Fir	Fc - Perp	405.0 psi		
Wood Grade	No.2	Fv	150.0 psi		
		Ft	525.0 psi	Density	26.840pcf
Beam Bracing	Beam is Fully Braced against lateral-torsional buckling				

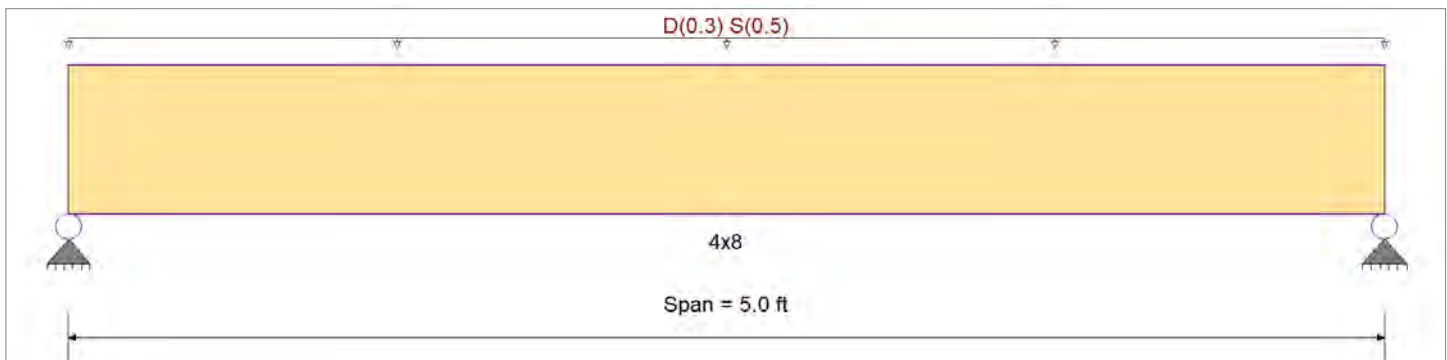

### Applied Loads

Service loads entered. Load Factors will be applied for calculations.

Beam self weight calculated and added to loads

Uniform Load : D = 0.0150, S = 0.0250 ksf, Tributary Width = 20.0 ft, (ROOF)

### DESIGN SUMMARY

**Design OK**

Maximum Bending Stress Ratio	=	<b>0.775</b> : 1	Maximum Shear Stress Ratio	=	<b>0.523</b> : 1
Section used for this span	=	<b>4x8</b>	Section used for this span	=	<b>4x8</b>
	=	984.21 psi		=	90.28 psi
	=	1,270.75 psi		=	172.50 psi
Load Combination	=	<b>+D+S+H</b>	Load Combination	=	<b>+D+S+H</b>
Location of maximum on span	=	2.500ft	Location of maximum on span	=	0.000ft
Span # where maximum occurs	=	Span # 1	Span # where maximum occurs	=	Span # 1
<b>Maximum Deflection</b>					
Max Downward Transient Deflection		0.049 in	Ratio =		1225 >=360
Max Upward Transient Deflection		0.000 in	Ratio =		0 <360
Max Downward Total Deflection		0.079 in	Ratio =		761 >=240
Max Upward Total Deflection		0.000 in	Ratio =		0 <240

### Maximum Forces & Stresses for Load Combinations

Load Combination	Segment Length	Span #	Max Stress Ratios									Moment Values			Shear Values							
			M	V	C <sub>d</sub>	C <sub>F/V</sub>	C <sub>i</sub>	C <sub>r</sub>	C <sub>m</sub>	C <sub>t</sub>	C <sub>L</sub>	M	fb	F'b	V	fv	F'v					
+D+H	Length = 5.0 ft	1	0.375	0.253	0.90	1.300	1.00	1.00	1.00	1.00	1.00	1.00	1.00	0.95	372.69	994.50	0.00	0.00	0.00	0.58	34.19	135.00
+D+L+H	Length = 5.0 ft	1	0.337	0.228	1.00	1.300	1.00	1.00	1.00	1.00	1.00	1.00	1.00	0.95	372.69	1105.00	0.00	0.00	0.00	0.58	34.19	150.00
+D+Lr+H	Length = 5.0 ft	1	0.270	0.182	1.25	1.300	1.00	1.00	1.00	1.00	1.00	1.00	1.00	0.95	372.69	1381.25	0.00	0.00	0.00	0.58	34.19	187.50
+D+S+H	Length = 5.0 ft	1	0.775	0.523	1.15	1.300	1.00	1.00	1.00	1.00	1.00	1.00	1.00	2.51	984.21	1270.75	0.00	0.00	0.00	1.53	90.28	172.50
+D+0.750Lr+0.750L+H	Length = 5.0 ft	1	0.270	0.182	1.25	1.300	1.00	1.00	1.00	1.00	1.00	1.00	1.00	0.95	372.69	1381.25	0.00	0.00	0.00	0.58	34.19	187.50
+D+0.750L+0.750S+H	Length = 5.0 ft	1	0.654	0.442	1.15	1.300	1.00	1.00	1.00	1.00	1.00	1.00	1.00	2.12	831.33	1270.75	0.00	0.00	0.00	1.29	76.26	172.50
+D+0.60W+H						1.300	1.00	1.00	1.00	1.00	1.00	1.00	1.00			0.00	0.00	0.00	0.00	0.00	0.00	0.00

**Wood Beam**

Lic. # : KW-06009431

**DESCRIPTIO HDR#2**

Load Combination	Segment Length	Span #	Max Stress Ratios									Moment Values			Shear Values		
			M	V	C <sub>d</sub>	C <sub>F/V</sub>	C <sub>i</sub>	C <sub>r</sub>	C <sub>m</sub>	C <sub>t</sub>	C <sub>L</sub>	M	fb	F'b	V	fv	Fv
Length = 5.0 ft	1	0.211	0.142	1.60	1.300	1.00	1.00	1.00	1.00	1.00	1.00	0.95	372.69	1768.00	0.58	34.19	240.00
+D+0.750Lr+0.750L+0.450W-					1.300	1.00	1.00	1.00	1.00	1.00	1.00			0.00	0.00	0.00	0.00
Length = 5.0 ft	1	0.211	0.142	1.60	1.300	1.00	1.00	1.00	1.00	1.00	1.00	0.95	372.69	1768.00	0.58	34.19	240.00
+D+0.750L+0.750S+0.450W+					1.300	1.00	1.00	1.00	1.00	1.00	1.00			0.00	0.00	0.00	0.00
Length = 5.0 ft	1	0.470	0.318	1.60	1.300	1.00	1.00	1.00	1.00	1.00	1.00	2.12	831.33	1768.00	1.29	76.26	240.00
+0.60D+0.60W+0.60H					1.300	1.00	1.00	1.00	1.00	1.00	1.00			0.00	0.00	0.00	0.00
Length = 5.0 ft	1	0.126	0.085	1.60	1.300	1.00	1.00	1.00	1.00	1.00	1.00	0.57	223.62	1768.00	0.35	20.51	240.00
+D+0.70E+0.60H					1.300	1.00	1.00	1.00	1.00	1.00	1.00			0.00	0.00	0.00	0.00
Length = 5.0 ft	1	0.211	0.142	1.60	1.300	1.00	1.00	1.00	1.00	1.00	1.00	0.95	372.69	1768.00	0.58	34.19	240.00
+D+0.750L+0.750S+0.5250E-					1.300	1.00	1.00	1.00	1.00	1.00	1.00			0.00	0.00	0.00	0.00
Length = 5.0 ft	1	0.470	0.318	1.60	1.300	1.00	1.00	1.00	1.00	1.00	1.00	2.12	831.33	1768.00	1.29	76.26	240.00
+0.60D+0.70E+H					1.300	1.00	1.00	1.00	1.00	1.00	1.00			0.00	0.00	0.00	0.00
Length = 5.0 ft	1	0.126	0.085	1.60	1.300	1.00	1.00	1.00	1.00	1.00	1.00	0.57	223.62	1768.00	0.35	20.51	240.00

**Overall Maximum Deflections**

Load Combination	Span	Max. "-" Defl	Location in Span	Load Combination	Max. "+" Defl	Location in Span
+D+S+H	1	0.0788	2.518		0.0000	0.000

**Vertical Reactions**

Support notation : Far left is #'

Values in KIPS

Load Combination	Support 1	Support 2
Overall MAXimum	2.012	2.012
Overall MINimum	1.250	1.250
+D+H	0.762	0.762
+D+L+H	0.762	0.762
+D+Lr+H	0.762	0.762
+D+S+H	2.012	2.012
+D+0.750Lr+0.750L+H	0.762	0.762
+D+0.750L+0.750S+H	1.699	1.699
+D+0.60W+H	0.762	0.762
+D+0.750Lr+0.750L+0.450W+H	0.762	0.762
+D+0.750L+0.750S+0.450W+H	1.699	1.699
+0.60D+0.60W+0.60H	0.457	0.457
+D+0.70E+0.60H	0.762	0.762
+D+0.750L+0.750S+0.5250E+H	1.699	1.699
+0.60D+0.70E+H	0.457	0.457
D Only	0.762	0.762
Lr Only		
L Only		
S Only	1.250	1.250
W Only		
E Only		
H Only		

## Wood Beam

Lic. #: KW-06009431

### DESCRIPTION HDR#3

### CODE REFERENCES

Calculations per NDS 2015, IBC 2015, CBC 2016, ASCE 7-10  
Load Combination Set : ASCE 7-16

### Material Properties

Analysis Method	Allowable Stress Design	Fb +	850.0 psi	E : Modulus of Elasticity	
Load Combination	ASCE 7-16	Fb -	850.0 psi	Ebend- xx	1,300.0ksi
Wood Species	Hem Fir	Fc - Prll	1,300.0 psi	Eminbend - x	470.0ksi
Wood Grade	No.2	Fc - Perp	405.0 psi		
		Fv	150.0 psi		
		Ft	525.0 psi	Density	26.840pcf
Beam Bracing	Beam is Fully Braced against lateral-torsional buckling				

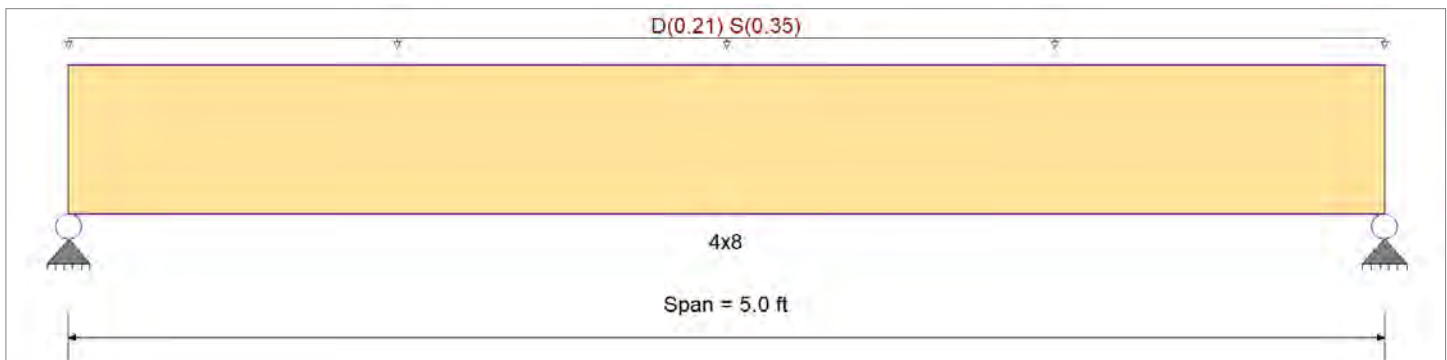

### Applied Loads

Service loads entered. Load Factors will be applied for calculations.

Beam self weight calculated and added to loads

Uniform Load : D = 0.0150, S = 0.0250 ksf, Tributary Width = 14.0 ft, (ROOF)

### DESIGN SUMMARY

**Design OK**

Maximum Bending Stress Ratio	=	<b>0.544</b> : 1	Maximum Shear Stress Ratio	=	<b>0.367</b> : 1
Section used for this span	=	<b>4x8</b>	Section used for this span	=	<b>4x8</b>
	=	690.68psi		=	63.35 psi
	=	1,270.75psi		=	172.50 psi
Load Combination	=	+D+S+H	Load Combination	=	+D+S+H
Location of maximum on span	=	2.500ft	Location of maximum on span	=	0.000ft
Span # where maximum occurs	=	Span # 1	Span # where maximum occurs	=	Span # 1
<b>Maximum Deflection</b>					
Max Downward Transient Deflection		0.034 in	Ratio =		1751 >=360
Max Upward Transient Deflection		0.000 in	Ratio =		0 <360
Max Downward Total Deflection		0.055 in	Ratio =		1085 >=240
Max Upward Total Deflection		0.000 in	Ratio =		0 <240

### Maximum Forces & Stresses for Load Combinations

Load Combination	Segment Length	Span #	Max Stress Ratios									Moment Values			Shear Values								
			M	V	C <sub>d</sub>	C <sub>F/V</sub>	C <sub>i</sub>	C <sub>r</sub>	C <sub>m</sub>	C <sub>t</sub>	C <sub>L</sub>	M	fb	F'b	V	fv	F'v						
+D+H	Length = 5.0 ft	1	0.264	0.178	0.90	1.300	1.00	1.00	1.00	1.00	1.00	1.00	1.00	0.67	262.62	994.50	0.00	0.00	0.00	0.41	24.09	135.00	
+D+L+H	Length = 5.0 ft	1	0.238	0.161	1.00	1.300	1.00	1.00	1.00	1.00	1.00	1.00	1.00	0.67	262.62	1105.00	0.00	0.00	0.00	0.00	0.00	0.00	0.00
+D+Lr+H	Length = 5.0 ft	1	0.190	0.128	1.25	1.300	1.00	1.00	1.00	1.00	1.00	1.00	1.00	0.67	262.62	1381.25	0.00	0.00	0.00	0.41	24.09	187.50	
+D+S+H	Length = 5.0 ft	1	0.544	0.367	1.15	1.300	1.00	1.00	1.00	1.00	1.00	1.00	1.00	1.76	690.68	1270.75	0.00	0.00	0.00	1.07	63.35	172.50	
+D+0.750Lr+0.750L+H	Length = 5.0 ft	1	0.190	0.128	1.25	1.300	1.00	1.00	1.00	1.00	1.00	1.00	1.00	0.67	262.62	1381.25	0.00	0.00	0.00	0.41	24.09	187.50	
+D+0.750L+0.750S+H	Length = 5.0 ft	1	0.459	0.310	1.15	1.300	1.00	1.00	1.00	1.00	1.00	1.00	1.00	1.49	583.67	1270.75	0.00	0.00	0.00	0.91	53.54	172.50	
+D+0.60W+H						1.300	1.00	1.00	1.00	1.00	1.00	1.00	1.00			0.00	0.00	0.00	0.00	0.00	0.00	0.00	



**Wood Beam**

Lic. # : KW-06009431

**DESCRIPTIO HDR#3**

Load Combination	Segment Length	Span #	Max Stress Ratios									Moment Values			Shear Values		
			M	V	C <sub>d</sub>	C <sub>F/V</sub>	C <sub>i</sub>	C <sub>r</sub>	C <sub>m</sub>	C <sub>t</sub>	C <sub>L</sub>	M	fb	F'b	V	fv	Fv
Length = 5.0 ft	1	0.149	0.100	1.60	1.300	1.00	1.00	1.00	1.00	1.00	1.00	0.67	262.62	1768.00	0.41	24.09	240.00
+D+0.750Lr+0.750L+0.450W-					1.300	1.00	1.00	1.00	1.00	1.00	1.00			0.00	0.00	0.00	0.00
Length = 5.0 ft	1	0.149	0.100	1.60	1.300	1.00	1.00	1.00	1.00	1.00	1.00	0.67	262.62	1768.00	0.41	24.09	240.00
+D+0.750L+0.750S+0.450W+					1.300	1.00	1.00	1.00	1.00	1.00	1.00			0.00	0.00	0.00	0.00
Length = 5.0 ft	1	0.330	0.223	1.60	1.300	1.00	1.00	1.00	1.00	1.00	1.00	1.49	583.67	1768.00	0.91	53.54	240.00
+0.60D+0.60W+0.60H					1.300	1.00	1.00	1.00	1.00	1.00	1.00			0.00	0.00	0.00	0.00
Length = 5.0 ft	1	0.089	0.060	1.60	1.300	1.00	1.00	1.00	1.00	1.00	1.00	0.40	157.57	1768.00	0.24	14.45	240.00
+D+0.70E+0.60H					1.300	1.00	1.00	1.00	1.00	1.00	1.00			0.00	0.00	0.00	0.00
Length = 5.0 ft	1	0.149	0.100	1.60	1.300	1.00	1.00	1.00	1.00	1.00	1.00	0.67	262.62	1768.00	0.41	24.09	240.00
+D+0.750L+0.750S+0.5250E-					1.300	1.00	1.00	1.00	1.00	1.00	1.00			0.00	0.00	0.00	0.00
Length = 5.0 ft	1	0.330	0.223	1.60	1.300	1.00	1.00	1.00	1.00	1.00	1.00	1.49	583.67	1768.00	0.91	53.54	240.00
+0.60D+0.70E+H					1.300	1.00	1.00	1.00	1.00	1.00	1.00			0.00	0.00	0.00	0.00
Length = 5.0 ft	1	0.089	0.060	1.60	1.300	1.00	1.00	1.00	1.00	1.00	1.00	0.40	157.57	1768.00	0.24	14.45	240.00

**Overall Maximum Deflections**

Load Combination	Span	Max. "-" Defl	Location in Span	Load Combination	Max. "+" Defl	Location in Span
+D+S+H	1	0.0553	2.518		0.0000	0.000

**Vertical Reactions**

Support notation : Far left is #'

Values in KIPS

Load Combination	Support 1	Support 2
Overall MAXimum	1.412	1.412
Overall MINimum	0.875	0.875
+D+H	0.537	0.537
+D+L+H	0.537	0.537
+D+Lr+H	0.537	0.537
+D+S+H	1.412	1.412
+D+0.750Lr+0.750L+H	0.537	0.537
+D+0.750L+0.750S+H	1.193	1.193
+D+0.60W+H	0.537	0.537
+D+0.750Lr+0.750L+0.450W+H	0.537	0.537
+D+0.750L+0.750S+0.450W+H	1.193	1.193
+0.60D+0.60W+0.60H	0.322	0.322
+D+0.70E+0.60H	0.537	0.537
+D+0.750L+0.750S+0.5250E+H	1.193	1.193
+0.60D+0.70E+H	0.322	0.322
D Only	0.537	0.537
Lr Only		
L Only		
S Only	0.875	0.875
W Only		
E Only		
H Only		

## Wood Beam

Lic. # : KW-06009431

### DESCRIPTIO HDR#4

### CODE REFERENCES

Calculations per NDS 2015, IBC 2015, CBC 2016, ASCE 7-10  
Load Combination Set : ASCE 7-16

### Material Properties

Analysis Method	Allowable Stress Design	Fb +	2400 psi	E : Modulus of Elasticity	
Load Combination	ASCE 7-16	Fb -	1850 psi	Ebend- xx	1800ksi
Wood Species	DF/DF	Fc - Prll	1650 psi	Eminbend - x	950ksi
Wood Grade	24F - V4	Fc - Perp	650 psi	Ebend- yy	1600ksi
		Fv	265 psi	Eminbend - y	850ksi
		Ft	1100 psi	Density	31.21 pcf
Beam Bracing	Beam is Fully Braced against lateral-torsional buckling				

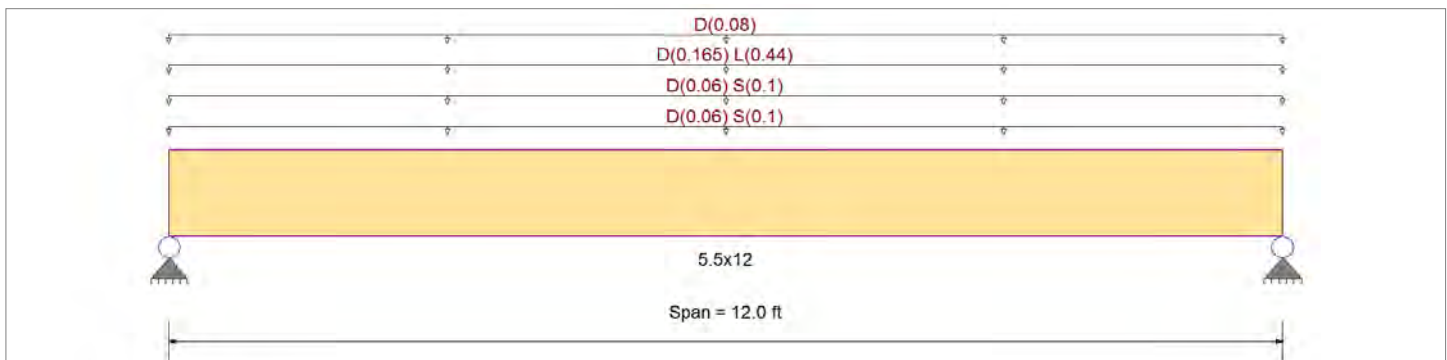

### Applied Loads

Service loads entered. Load Factors will be applied for calculations.

Beam self weight calculated and added to loads

- Uniform Load : D = 0.0150, S = 0.0250 ksf, Tributary Width = 4.0 ft, (UPPER ROOF)
- Uniform Load : D = 0.0150, S = 0.0250 ksf, Tributary Width = 4.0 ft, (UPPER ROOF)
- Uniform Load : D = 0.0150, L = 0.040 ksf, Tributary Width = 11.0 ft, (FLOOR)
- Uniform Load : D = 0.010 ksf, Tributary Width = 8.0 ft, (WALL)

### DESIGN SUMMARY

**Design OK**

Maximum Bending Stress Ratio	=	<b>0.559</b> < 1	Maximum Shear Stress Ratio	=	<b>0.354</b> < 1
Section used for this span	=	<b>5.5x12</b>	Section used for this span	=	<b>5.5x12</b>
	=	1,340.68psi		=	93.78 psi
	=	2,400.00psi		=	265.00 psi
Load Combination	=	+D+L+H	Load Combination	=	+D+L+H
Location of maximum on span	=	6.000ft	Location of maximum on span	=	0.000ft
Span # where maximum occurs	=	Span # 1	Span # where maximum occurs	=	Span # 1
<b>Maximum Deflection</b>					
Max Downward Transient Deflection		0.145 in	Ratio =		994 >=360
Max Upward Transient Deflection		0.000 in	Ratio =		0 <360
Max Downward Total Deflection		0.283 in	Ratio =		509 >=240
Max Upward Total Deflection		0.000 in	Ratio =		0 <240

### Maximum Forces & Stresses for Load Combinations

Load Combination	Segment Length	Span #	Max Stress Ratios									Moment Values			Shear Values						
			M	V	C <sub>d</sub>	C <sub>F/V</sub>	C <sub>i</sub>	C <sub>r</sub>	C <sub>m</sub>	C <sub>t</sub>	C <sub>L</sub>	M	fb	F'b	V	fv	F'v				
+D+H	Length = 12.0 ft	1	0.287	0.182	0.90	1.000	1.00	1.00	1.00	1.00	1.00	1.00	1.00	1.00	1.00	0.00	0.00	0.00	0.00	0.00	238.50
+D+L+H	Length = 12.0 ft	1	0.559	0.354	1.00	1.000	1.00	1.00	1.00	1.00	1.00	1.00	1.00	1.00	14.75	1,340.68	2400.00	4.13	93.78	265.00	0.00
+D+Lr+H	Length = 12.0 ft	1	0.207	0.131	1.25	1.000	1.00	1.00	1.00	1.00	1.00	1.00	1.00	1.00	6.83	620.68	3000.00	1.91	43.42	331.25	0.00
+D+S+H	Length = 12.0 ft	1	0.343	0.218	1.15	1.000	1.00	1.00	1.00	1.00	1.00	1.00	1.00	1.00	10.43	947.95	2760.00	2.92	66.31	304.75	0.00
+D+0.750Lr+0.750L+H	Length = 12.0 ft	1	0.387	0.245	1.25	1.000	1.00	1.00	1.00	1.00	1.00	1.00	1.00	1.00	12.77	1,160.68	3000.00	3.57	81.19	331.25	0.00

**Wood Beam**

Lic. # : KW-06009431

**DESCRIPTIO HDR#4**

Load Combination	Segment Length	Span #	Max Stress Ratios								Moment Values			Shear Values									
			M	V	C <sub>d</sub>	C <sub>F/V</sub>	C <sub>i</sub>	C <sub>r</sub>	C <sub>m</sub>	C <sub>t</sub>	C <sub>L</sub>	M	fb	F'b	V	f <sub>v</sub>	F <sub>v</sub>						
+D+0.750L+0.750S+H	Length = 12.0 ft	1	0.509	0.323	1.15	1.000	1.00	1.00	1.00	1.00	1.00	1.00	1.00	1.00	15.47	1,406.13	2760.00	0.00	0.00	0.00	4.33	98.36	304.75
+D+0.60W+H	Length = 12.0 ft	1	0.162	0.102	1.60	1.000	1.00	1.00	1.00	1.00	1.00	1.00	1.00	1.00	6.83	620.68	3840.00	0.00	0.00	0.00	1.91	43.42	424.00
+D+0.750Lr+0.750L+0.450W-	Length = 12.0 ft	1	0.302	0.191	1.60	1.000	1.00	1.00	1.00	1.00	1.00	1.00	1.00	1.00	12.77	1,160.68	3840.00	0.00	0.00	0.00	3.57	81.19	424.00
+D+0.750L+0.750S+0.450W+	Length = 12.0 ft	1	0.366	0.232	1.60	1.000	1.00	1.00	1.00	1.00	1.00	1.00	1.00	1.00	15.47	1,406.13	3840.00	0.00	0.00	0.00	4.33	98.36	424.00
+0.60D+0.60W+0.60H	Length = 12.0 ft	1	0.097	0.061	1.60	1.000	1.00	1.00	1.00	1.00	1.00	1.00	1.00	1.00	4.10	372.41	3840.00	0.00	0.00	0.00	1.15	26.05	424.00
+D+0.70E+0.60H	Length = 12.0 ft	1	0.162	0.102	1.60	1.000	1.00	1.00	1.00	1.00	1.00	1.00	1.00	1.00	6.83	620.68	3840.00	0.00	0.00	0.00	1.91	43.42	424.00
+D+0.750L+0.750S+0.5250E-	Length = 12.0 ft	1	0.366	0.232	1.60	1.000	1.00	1.00	1.00	1.00	1.00	1.00	1.00	1.00	15.47	1,406.13	3840.00	0.00	0.00	0.00	4.33	98.36	424.00
+0.60D+0.70E+H	Length = 12.0 ft	1	0.097	0.061	1.60	1.000	1.00	1.00	1.00	1.00	1.00	1.00	1.00	1.00	4.10	372.41	3840.00	0.00	0.00	0.00	1.15	26.05	424.00

**Overall Maximum Deflections**

Load Combination	Span	Max. "-" Defl	Location in Span	Load Combination	Max. "+" Defl	Location in Span
+D+0.750L+0.750S+0.5250E+H	1	0.2829	6.044		0.0000	0.000

**Vertical Reactions**

Load Combination	Support notation : Far left is #'		Values in KIPS	
	Support 1	Support 2		
Overall MAXimum	5.156	5.156		
Overall MINimum	1.200	1.200		
+D+H	2.276	2.276		
+D+L+H	4.916	4.916		
+D+Lr+H	2.276	2.276		
+D+S+H	3.476	3.476		
+D+0.750Lr+0.750L+H	4.256	4.256		
+D+0.750L+0.750S+H	5.156	5.156		
+D+0.60W+H	2.276	2.276		
+D+0.750Lr+0.750L+0.450W+H	4.256	4.256		
+D+0.750L+0.750S+0.450W+H	5.156	5.156		
+0.60D+0.60W+0.60H	1.365	1.365		
+D+0.70E+0.60H	2.276	2.276		
+D+0.750L+0.750S+0.5250E+H	5.156	5.156		
+0.60D+0.70E+H	1.365	1.365		
D Only	2.276	2.276		
Lr Only				
L Only	2.640	2.640		
S Only	1.200	1.200		
W Only				
E Only				
H Only				



## Wood Beam

Lic. # : KW-06009431

### DESCRIPTION HDR#5

### CODE REFERENCES

Calculations per NDS 2015, IBC 2015, CBC 2016, ASCE 7-10  
Load Combination Set : ASCE 7-16

### Material Properties

Analysis Method	Allowable Stress Design	Fb +	2,400.0 psi	E : Modulus of Elasticity	
Load Combination	ASCE 7-16	Fb -	1,850.0 psi	Ebend- xx	1,800.0ksi
Wood Species	DF/DF	Fc - Prll	1,650.0 psi	Eminbend - x	950.0ksi
Wood Grade	24F - V4	Fc - Perp	650.0 psi	Ebend- yy	1,600.0ksi
		Fv	265.0 psi	Eminbend - y	850.0ksi
		Ft	1,100.0 psi	Density	31.210pcf
Beam Bracing	Beam is Fully Braced against lateral-torsional buckling				

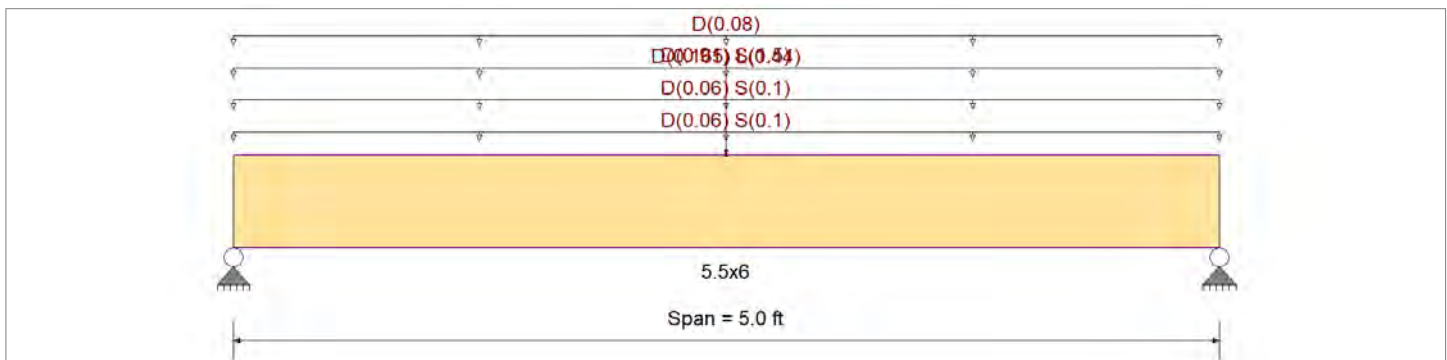

### Applied Loads

Service loads entered. Load Factors will be applied for calculations.

Beam self weight calculated and added to loads

- Uniform Load : D = 0.0150, S = 0.0250 ksf, Tributary Width = 4.0 ft, (UPPER ROOF)
- Uniform Load : D = 0.0150, S = 0.0250 ksf, Tributary Width = 4.0 ft, (UPPER ROOF)
- Uniform Load : D = 0.0150, L = 0.040 ksf, Tributary Width = 11.0 ft, (FLOOR)
- Uniform Load : D = 0.010 ksf, Tributary Width = 8.0 ft, (WALL)
- Point Load : D = 0.910, S = 1.50 k @ 2.50 ft, (HDR#1)

### DESIGN SUMMARY

**Design OK**

Maximum Bending Stress Ratio	=	<b>0.686</b>	1	Maximum Shear Stress Ratio	=	<b>0.407</b>	1
Section used for this span		<b>5.5x6</b>		Section used for this span		<b>5.5x6</b>	
	=	1,893.35	psi		=	124.00	psi
	=	2,760.00	psi		=	304.75	psi
Load Combination	+D+0.750L+0.750S+H			Load Combination	+D+0.750L+0.750S+H		
Location of maximum on span	=	2.500	ft	Location of maximum on span	=	0.000	ft
Span # where maximum occurs	=	Span # 1		Span # where maximum occurs	=	Span # 1	
<b>Maximum Deflection</b>							
Max Downward Transient Deflection		0.054	in	Ratio =	1111	>=360	
Max Upward Transient Deflection		0.000	in	Ratio =	0	<360	
Max Downward Total Deflection		0.119	in	Ratio =	502	>=240	
Max Upward Total Deflection		0.000	in	Ratio =	0	<240	

### Maximum Forces & Stresses for Load Combinations

Load Combination	Segment Length	Span #	Max Stress Ratios									Moment Values			Shear Values								
			M	V	C <sub>d</sub>	C <sub>F/V</sub>	C <sub>i</sub>	C <sub>r</sub>	C <sub>m</sub>	C <sub>t</sub>	C <sub>L</sub>	M	fb	F'b	V	fv	F'v						
+D+H	Length = 5.0 ft	1	0.387	0.229	0.90	1.000	1.00	1.00	1.00	1.00	1.00	1.00	1.00	1.00	2.30	836.54	2160.00	0.00	0.00	0.00	0.00	0.00	238.50
+D+L+H	Length = 5.0 ft	1	0.557	0.358	1.00	1.000	1.00	1.00	1.00	1.00	1.00	1.00	1.00	1.00	3.68	1,336.54	2400.00	0.00	0.00	0.00	0.00	0.00	265.00
+D+Lr+H	Length = 5.0 ft	1	0.279	0.165	1.25	1.000	1.00	1.00	1.00	1.00	1.00	1.00	1.00	1.00	2.30	836.54	3000.00	0.00	0.00	0.00	0.00	0.00	331.25
+D+S+H	Length = 5.0 ft	1	0.632	0.351	1.15	1.000	1.00	1.00	1.00	1.00	1.00	1.00	1.00	1.00	4.80	1,745.63	2760.00	0.00	0.00	0.00	0.00	0.00	304.75
+D+0.750Lr+0.750L+H						1.000	1.00	1.00	1.00	1.00	1.00	1.00	1.00	1.00			0.00	0.00	0.00	0.00	0.00	0.00	0.00

**Wood Beam**

Lic. # : KW-06009431

**DESCRIPTIO HDR#5**

Load Combination	Segment Length	Span #	Max Stress Ratios									Moment Values			Shear Values		
			M	V	C <sub>d</sub>	C <sub>F/V</sub>	C <sub>i</sub>	C <sub>r</sub>	C <sub>m</sub>	C <sub>t</sub>	C <sub>L</sub>	M	fb	F'b	V	fv	Fv
	Length = 5.0 ft	1	0.404	0.256	1.25	1.000	1.00	1.00	1.00	1.00	1.00	3.33	1,211.54	3000.00	1.86	84.75	331.25
+D+0.750L+0.750S+H						1.000	1.00	1.00	1.00	1.00	1.00			0.00	0.00	0.00	0.00
	Length = 5.0 ft	1	0.686	0.407	1.15	1.000	1.00	1.00	1.00	1.00	5.21	1,893.35	2760.00	2.73	124.00	304.75	
+D+0.60W+H						1.000	1.00	1.00	1.00	1.00			0.00	0.00	0.00	0.00	
	Length = 5.0 ft	1	0.218	0.129	1.60	1.000	1.00	1.00	1.00	1.00	2.30	836.54	3840.00	1.20	54.64	424.00	
+D+0.750Lr+0.750L+0.450W-						1.000	1.00	1.00	1.00	1.00			0.00	0.00	0.00	0.00	
	Length = 5.0 ft	1	0.316	0.200	1.60	1.000	1.00	1.00	1.00	1.00	3.33	1,211.54	3840.00	1.86	84.75	424.00	
+D+0.750L+0.750S+0.450W+						1.000	1.00	1.00	1.00	1.00			0.00	0.00	0.00	0.00	
	Length = 5.0 ft	1	0.493	0.292	1.60	1.000	1.00	1.00	1.00	1.00	5.21	1,893.35	3840.00	2.73	124.00	424.00	
+0.60D+0.60W+0.60H						1.000	1.00	1.00	1.00	1.00			0.00	0.00	0.00	0.00	
	Length = 5.0 ft	1	0.131	0.077	1.60	1.000	1.00	1.00	1.00	1.00	1.38	501.92	3840.00	0.72	32.78	424.00	
+D+0.70E+0.60H						1.000	1.00	1.00	1.00	1.00			0.00	0.00	0.00	0.00	
	Length = 5.0 ft	1	0.218	0.129	1.60	1.000	1.00	1.00	1.00	1.00	2.30	836.54	3840.00	1.20	54.64	424.00	
+D+0.750L+0.750S+0.5250E-						1.000	1.00	1.00	1.00	1.00			0.00	0.00	0.00	0.00	
	Length = 5.0 ft	1	0.493	0.292	1.60	1.000	1.00	1.00	1.00	1.00	5.21	1,893.35	3840.00	2.73	124.00	424.00	
+0.60D+0.70E+H						1.000	1.00	1.00	1.00	1.00			0.00	0.00	0.00	0.00	
	Length = 5.0 ft	1	0.131	0.077	1.60	1.000	1.00	1.00	1.00	1.00	1.38	501.92	3840.00	0.72	32.78	424.00	

**Overall Maximum Deflections**

Load Combination	Span	Max. "-" Defl	Location in Span	Load Combination	Max. "+" Defl	Location in Span
+D+0.750L+0.750S+0.5250E+H	1	0.1193	2.518		0.0000	0.000

**Vertical Reactions**

Load Combination	Support notation : Far left is #'		Values in KIPS	
	Support 1	Support 2		
Overall MAXimum	3.148	3.148		
Overall MINimum	1.250	1.250		
+D+H	1.385	1.385		
+D+L+H	2.485	2.485		
+D+Lr+H	1.385	1.385		
+D+S+H	2.635	2.635		
+D+0.750Lr+0.750L+H	2.210	2.210		
+D+0.750L+0.750S+H	3.148	3.148		
+D+0.60W+H	1.385	1.385		
+D+0.750Lr+0.750L+0.450W+H	2.210	2.210		
+D+0.750L+0.750S+0.450W+H	3.148	3.148		
+0.60D+0.60W+0.60H	0.831	0.831		
+D+0.70E+0.60H	1.385	1.385		
+D+0.750L+0.750S+0.5250E+H	3.148	3.148		
+0.60D+0.70E+H	0.831	0.831		
D Only	1.385	1.385		
Lr Only				
L Only	1.100	1.100		
S Only	1.250	1.250		
W Only				
E Only				
H Only				

**Wood Beam**

Lic. # : KW-06009431

**DESCRIPTIO HDR#6**

**CODE REFERENCES**

Calculations per NDS 2015, IBC 2015, CBC 2016, ASCE 7-10  
 Load Combination Set : ASCE 7-16

**Material Properties**

Analysis Method	Allowable Stress Design	Fb +	2,400.0 psi	E : Modulus of Elasticity	
Load Combination	ASCE 7-16	Fb -	1,850.0 psi	Ebend- xx	1,800.0ksi
Wood Species	DF/DF	Fc - Prll	1,650.0 psi	Eminbend - x	950.0ksi
Wood Grade	24F - V4	Fc - Perp	650.0 psi	Ebend- yy	1,600.0ksi
		Fv	265.0 psi	Eminbend - y	850.0ksi
		Ft	1,100.0 psi	Density	31.210pcf

Beam Bracing Beam is Fully Braced against lateral-torsional buckling

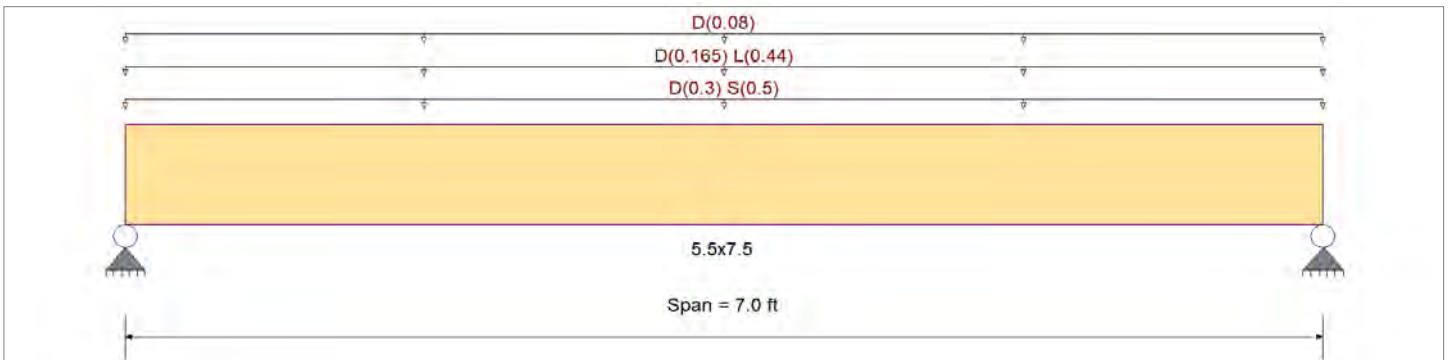

**Applied Loads**

Service loads entered. Load Factors will be applied for calculations.

Beam self weight calculated and added to loads

Uniform Load : D = 0.0150, S = 0.0250 ksf, Tributary Width = 20.0 ft, (UPPER ROOF)

Uniform Load : D = 0.0150, L = 0.040 ksf, Tributary Width = 11.0 ft, (FLOOR)

Uniform Load : D = 0.010 ksf, Tributary Width = 8.0 ft, (WALL)

**DESIGN SUMMARY**

**Design OK**

Maximum Bending Stress Ratio	=	<b>0.650</b>	1	Maximum Shear Stress Ratio	=	<b>0.434</b>	: 1
Section used for this span		<b>5.5x7.5</b>		Section used for this span		<b>5.5x7.5</b>	
	=	1,794.56psi			=	132.16 psi	
	=	2,760.00psi			=	304.75 psi	
Load Combination	+D+0.750L+0.750S+H			Load Combination	+D+0.750L+0.750S+H		
Location of maximum on span	=	3.500ft		Location of maximum on span	=	6.387 ft	
Span # where maximum occurs	=	Span # 1		Span # where maximum occurs	=	Span # 1	
<b>Maximum Deflection</b>							
Max Downward Transient Deflection		0.078 in	Ratio =	1076	>=	360	
Max Upward Transient Deflection		0.000 in	Ratio =	0	<	360	
Max Downward Total Deflection		0.197 in	Ratio =	427	>=	240	
Max Upward Total Deflection		0.000 in	Ratio =	0	<	240	

**Maximum Forces & Stresses for Load Combinations**

Load Combination	Segment Length	Span #	Max Stress Ratios								Moment Values			Shear Values								
			M	V	C <sub>d</sub>	C <sub>F/V</sub>	C <sub>i</sub>	C <sub>r</sub>	C <sub>m</sub>	C <sub>t</sub>	C <sub>L</sub>	M	fb	F'b	V	fv	F'v					
+D+H	Length = 7.0 ft	1	0.366	0.244	0.90	1.000	1.00	1.00	1.00	1.00	1.00	1.00	1.00	3.39	789.62	2160.00	0.00	0.00	0.00	1.60	58.15	238.50
+D+L+H	Length = 7.0 ft	1	0.590	0.394	1.00	1.000	1.00	1.00	1.00	1.00	1.00	1.00	1.00	6.09	1,416.82	2400.00	0.00	0.00	0.00	2.87	104.34	265.00
+D+Lr+H	Length = 7.0 ft	1	0.263	0.176	1.25	1.000	1.00	1.00	1.00	1.00	1.00	1.00	1.00	3.39	789.62	3000.00	0.00	0.00	0.00	1.60	58.15	331.25
+D+S+H	Length = 7.0 ft	1	0.544	0.363	1.15	1.000	1.00	1.00	1.00	1.00	1.00	1.00	1.00	6.46	1,502.34	2760.00	0.00	0.00	0.00	3.04	110.64	304.75
+D+0.750Lr+0.750L+H	Length = 7.0 ft	1	0.420	0.280	1.25	1.000	1.00	1.00	1.00	1.00	1.00	1.00	1.00	5.41	1,260.02	3000.00	0.00	0.00	0.00	2.55	92.79	331.25
+D+0.750L+0.750S+H						1.000	1.00	1.00	1.00	1.00	1.00	1.00	1.00				0.00	0.00	0.00	0.00	0.00	0.00



**Wood Beam**

Lic. # : KW-06009431

**DESCRIPTIO HDR#6**

Load Combination	Segment Length	Span #	Max Stress Ratios									Moment Values			Shear Values		
			M	V	C <sub>d</sub>	C <sub>F/V</sub>	C <sub>i</sub>	C <sub>r</sub>	C <sub>m</sub>	C <sub>t</sub>	C <sub>L</sub>	M	fb	F'b	V	fv	Fv
	Length = 7.0 ft	1	0.650	0.434	1.15	1.000	1.00	1.00	1.00	1.00	1.00	7.71	1,794.56	2760.00	3.63	132.16	304.75
+D+0.60W+H						1.000	1.00	1.00	1.00	1.00	1.00			0.00	0.00	0.00	0.00
	Length = 7.0 ft	1	0.206	0.137	1.60	1.000	1.00	1.00	1.00	1.00	1.00	3.39	789.62	3840.00	1.60	58.15	424.00
+D+0.750Lr+0.750L+0.450W-						1.000	1.00	1.00	1.00	1.00	1.00			0.00	0.00	0.00	0.00
	Length = 7.0 ft	1	0.328	0.219	1.60	1.000	1.00	1.00	1.00	1.00	1.00	5.41	1,260.02	3840.00	2.55	92.79	424.00
+D+0.750L+0.750S+0.450W+						1.000	1.00	1.00	1.00	1.00	1.00			0.00	0.00	0.00	0.00
	Length = 7.0 ft	1	0.467	0.312	1.60	1.000	1.00	1.00	1.00	1.00	1.00	7.71	1,794.56	3840.00	3.63	132.16	424.00
+0.60D+0.60W+0.60H						1.000	1.00	1.00	1.00	1.00	1.00			0.00	0.00	0.00	0.00
	Length = 7.0 ft	1	0.123	0.082	1.60	1.000	1.00	1.00	1.00	1.00	1.00	2.04	473.77	3840.00	0.96	34.89	424.00
+D+0.70E+0.60H						1.000	1.00	1.00	1.00	1.00	1.00			0.00	0.00	0.00	0.00
	Length = 7.0 ft	1	0.206	0.137	1.60	1.000	1.00	1.00	1.00	1.00	1.00	3.39	789.62	3840.00	1.60	58.15	424.00
+D+0.750L+0.750S+0.5250E-						1.000	1.00	1.00	1.00	1.00	1.00			0.00	0.00	0.00	0.00
	Length = 7.0 ft	1	0.467	0.312	1.60	1.000	1.00	1.00	1.00	1.00	1.00	7.71	1,794.56	3840.00	3.63	132.16	424.00
+0.60D+0.70E+H						1.000	1.00	1.00	1.00	1.00	1.00			0.00	0.00	0.00	0.00
	Length = 7.0 ft	1	0.123	0.082	1.60	1.000	1.00	1.00	1.00	1.00	1.00	2.04	473.77	3840.00	0.96	34.89	424.00

**Overall Maximum Deflections**

Load Combination	Span	Max. "-" Defl	Location in Span	Load Combination	Max. "+" Defl	Location in Span
+D+0.750L+0.750S+0.5250E+H	1	0.1965	3.526		0.0000	0.000

**Vertical Reactions**

Load Combination	Support notation : Far left is #'		Values in KIPS	
	Support 1	Support 2		
Overall MAXimum	4.406	4.406		
Overall MINimum	1.750	1.750		
+D+H	1.939	1.939		
+D+L+H	3.479	3.479		
+D+Lr+H	1.939	1.939		
+D+S+H	3.689	3.689		
+D+0.750Lr+0.750L+H	3.094	3.094		
+D+0.750L+0.750S+H	4.406	4.406		
+D+0.60W+H	1.939	1.939		
+D+0.750Lr+0.750L+0.450W+H	3.094	3.094		
+D+0.750L+0.750S+0.450W+H	4.406	4.406		
+0.60D+0.60W+0.60H	1.163	1.163		
+D+0.70E+0.60H	1.939	1.939		
+D+0.750L+0.750S+0.5250E+H	4.406	4.406		
+0.60D+0.70E+H	1.163	1.163		
D Only	1.939	1.939		
Lr Only				
L Only	1.540	1.540		
S Only	1.750	1.750		
W Only				
E Only				
H Only				

## Wood Beam

Lic. #: KW-06009431

### DESCRIPTION HDR#7

### CODE REFERENCES

Calculations per NDS 2015, IBC 2015, CBC 2016, ASCE 7-10  
Load Combination Set : ASCE 7-16

### Material Properties

Analysis Method	Allowable Stress Design	Fb +	2,400.0 psi	E : Modulus of Elasticity	
Load Combination	ASCE 7-16	Fb -	1,850.0 psi	Ebend- xx	1,800.0ksi
Wood Species	DF/DF	Fc - Prll	1,650.0 psi	Eminbend - x	950.0ksi
Wood Grade	24F - V4	Fc - Perp	650.0 psi	Ebend- yy	1,600.0ksi
		Fv	265.0 psi	Eminbend - y	850.0ksi
		Ft	1,100.0 psi	Density	31.210pcf
Beam Bracing	Beam is Fully Braced against lateral-torsional buckling				

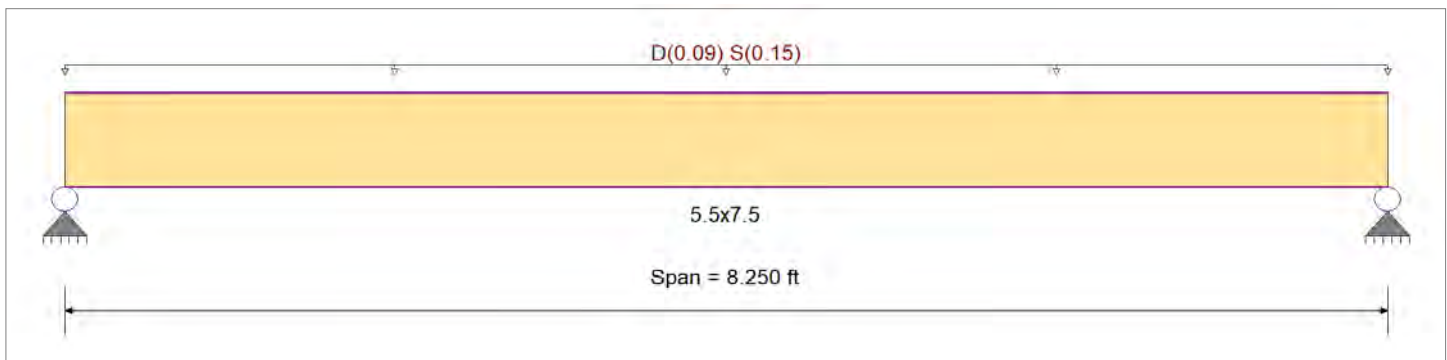

### Applied Loads

Service loads entered. Load Factors will be applied for calculations.

Beam self weight calculated and added to loads

Uniform Load : D = 0.0150, S = 0.0250 ksf, Tributary Width = 6.0 ft, (ROOF)

### DESIGN SUMMARY

**Design OK**

Maximum Bending Stress Ratio	=	<b>0.179</b> < 1	Maximum Shear Stress Ratio	=	<b>0.105</b> < 1
Section used for this span	=	<b>5.5x7.5</b>	Section used for this span	=	<b>5.5x7.5</b>
	=	492.90psi		=	31.89 psi
	=	2,760.00psi		=	304.75 psi
Load Combination	=	<b>+D+S+H</b>	Load Combination	=	<b>+D+S+H</b>
Location of maximum on span	=	4.125ft	Location of maximum on span	=	0.000ft
Span # where maximum occurs	=	Span # 1	Span # where maximum occurs	=	Span # 1
<b>Maximum Deflection</b>					
Max Downward Transient Deflection		0.045 in	Ratio =	2191	>=360
Max Upward Transient Deflection		0.000 in	Ratio =	0	<360
Max Downward Total Deflection		0.075 in	Ratio =	1320	>=240
Max Upward Total Deflection		0.000 in	Ratio =	0	<240

### Maximum Forces & Stresses for Load Combinations

Load Combination	Segment Length	Span #	Max Stress Ratios									Moment Values			Shear Values									
			M	V	C <sub>d</sub>	C <sub>F/V</sub>	C <sub>i</sub>	C <sub>r</sub>	C <sub>m</sub>	C <sub>t</sub>	C <sub>L</sub>	M	fb	F'b	V	fv	F'v							
+D+H	Length = 8.250 ft	1	0.091	0.053	0.90	1.000	1.00	1.00	1.00	1.00	1.00	1.00	1.00	1.00	0.84	195.90	2160.00	0.00	0.00	0.00	0.35	12.67	238.50	
+D+L+H	Length = 8.250 ft	1				1.000	1.00	1.00	1.00	1.00	1.00	1.00	1.00	1.00	0.84	195.90	2400.00	0.00	0.00	0.00	0.00	0.00	0.00	0.00
+D+Lr+H	Length = 8.250 ft	1	0.065	0.038	1.25	1.000	1.00	1.00	1.00	1.00	1.00	1.00	1.00	1.00	0.84	195.90	3000.00	0.00	0.00	0.00	0.35	12.67	331.25	
+D+S+H	Length = 8.250 ft	1	0.179	0.105	1.15	1.000	1.00	1.00	1.00	1.00	1.00	1.00	1.00	1.00	2.12	492.90	2760.00	0.00	0.00	0.00	0.88	31.89	304.75	
+D+0.750Lr+0.750L+H	Length = 8.250 ft	1	0.065	0.038	1.25	1.000	1.00	1.00	1.00	1.00	1.00	1.00	1.00	1.00	0.84	195.90	3000.00	0.00	0.00	0.00	0.35	12.67	331.25	
+D+0.750L+0.750S+H	Length = 8.250 ft	1				1.000	1.00	1.00	1.00	1.00	1.00	1.00	1.00	1.00				0.00	0.00	0.00	0.00	0.00	0.00	
+D+0.60W+H						1.000	1.00	1.00	1.00	1.00	1.00	1.00	1.00	1.00	1.80	418.65	2760.00	0.00	0.00	0.00	0.74	27.09	304.75	
							1.000	1.00	1.00	1.00	1.00	1.00	1.00	1.00				0.00	0.00	0.00	0.00	0.00	0.00	

**Wood Beam**

Lic. # : KW-06009431

**DESCRIPTIO HDR#7**

Load Combination	Segment Length	Span #	Max Stress Ratios									Moment Values			Shear Values		
			M	V	C <sub>d</sub>	C <sub>F/V</sub>	C <sub>i</sub>	C <sub>r</sub>	C <sub>m</sub>	C <sub>t</sub>	C <sub>L</sub>	M	fb	F'b	V	fv	F'v
Length = 8.250 ft	1	0.051	0.030	1.60	1.000	1.00	1.00	1.00	1.00	1.00	1.00	0.84	195.90	3840.00	0.35	12.67	424.00
+D+0.750Lr+0.750L+0.450W-					1.000	1.00	1.00	1.00	1.00	1.00	1.00			0.00	0.00	0.00	0.00
Length = 8.250 ft	1	0.051	0.030	1.60	1.000	1.00	1.00	1.00	1.00	1.00	1.00	0.84	195.90	3840.00	0.35	12.67	424.00
+D+0.750L+0.750S+0.450W+					1.000	1.00	1.00	1.00	1.00	1.00	1.00			0.00	0.00	0.00	0.00
Length = 8.250 ft	1	0.109	0.064	1.60	1.000	1.00	1.00	1.00	1.00	1.00	1.00	1.80	418.65	3840.00	0.74	27.09	424.00
+0.60D+0.60W+0.60H					1.000	1.00	1.00	1.00	1.00	1.00	1.00			0.00	0.00	0.00	0.00
Length = 8.250 ft	1	0.031	0.018	1.60	1.000	1.00	1.00	1.00	1.00	1.00	1.00	0.51	117.54	3840.00	0.21	7.60	424.00
+D+0.70E+0.60H					1.000	1.00	1.00	1.00	1.00	1.00	1.00			0.00	0.00	0.00	0.00
Length = 8.250 ft	1	0.051	0.030	1.60	1.000	1.00	1.00	1.00	1.00	1.00	1.00	0.84	195.90	3840.00	0.35	12.67	424.00
+D+0.750L+0.750S+0.5250E-					1.000	1.00	1.00	1.00	1.00	1.00	1.00			0.00	0.00	0.00	0.00
Length = 8.250 ft	1	0.109	0.064	1.60	1.000	1.00	1.00	1.00	1.00	1.00	1.00	1.80	418.65	3840.00	0.74	27.09	424.00
+0.60D+0.70E+H					1.000	1.00	1.00	1.00	1.00	1.00	1.00			0.00	0.00	0.00	0.00
Length = 8.250 ft	1	0.031	0.018	1.60	1.000	1.00	1.00	1.00	1.00	1.00	1.00	0.51	117.54	3840.00	0.21	7.60	424.00

**Overall Maximum Deflections**

Load Combination	Span	Max. "-" Defl	Location in Span	Load Combination	Max. "+" Defl	Location in Span
+D+S+H	1	0.0750	4.155		0.0000	0.000

**Vertical Reactions**

Support notation : Far left is #'

Values in KIPS

Load Combination	Support 1	Support 2
Overall MAXimum	1.027	1.027
Overall MINimum	0.619	0.619
+D+H	0.408	0.408
+D+L+H	0.408	0.408
+D+Lr+H	0.408	0.408
+D+S+H	1.027	1.027
+D+0.750Lr+0.750L+H	0.408	0.408
+D+0.750L+0.750S+H	0.872	0.872
+D+0.60W+H	0.408	0.408
+D+0.750Lr+0.750L+0.450W+H	0.408	0.408
+D+0.750L+0.750S+0.450W+H	0.872	0.872
+0.60D+0.60W+0.60H	0.245	0.245
+D+0.70E+0.60H	0.408	0.408
+D+0.750L+0.750S+0.5250E+H	0.872	0.872
+0.60D+0.70E+H	0.245	0.245
D Only	0.408	0.408
Lr Only		
L Only		
S Only	0.619	0.619
W Only		
E Only		
H Only		

## Wood Beam

Lic. #: KW-06009431

File = C:\Users\pasko\Desktop\test.ec6 .  
Software copyright ENERCALC, INC. 1983-2019, Build:12.19.11.30 .  
CK Engineering LLC

### DESCRIPTIO HDR#8

### CODE REFERENCES

Calculations per NDS 2015, IBC 2015, CBC 2016, ASCE 7-10  
Load Combination Set : ASCE 7-16

### Material Properties

Analysis Method	Allowable Stress Design	Fb +	2,400.0 psi	E : Modulus of Elasticity	
Load Combination	ASCE 7-16	Fb -	1,850.0 psi	Ebend- xx	1,800.0ksi
Wood Species	DF/DF	Fc - Prll	1,650.0 psi	Eminbend - x	950.0ksi
Wood Grade	24F - V4	Fc - Perp	650.0 psi	Ebend- yy	1,600.0ksi
		Fv	265.0 psi	Eminbend - y	850.0ksi
		Ft	1,100.0 psi	Density	31.210pcf
Beam Bracing	Beam is Fully Braced against lateral-torsional buckling				

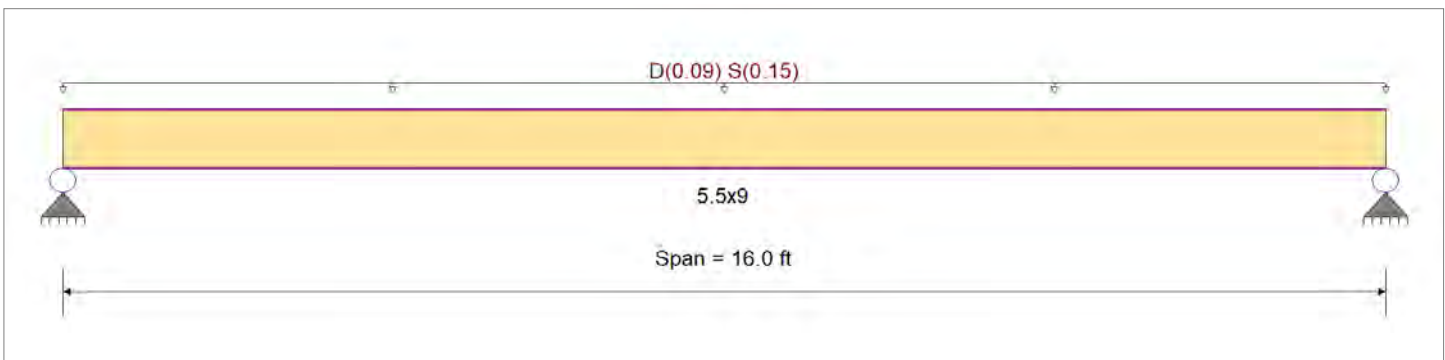

### Applied Loads

Service loads entered. Load Factors will be applied for calculations.

Beam self weight calculated and added to loads

Uniform Load : D = 0.0150, S = 0.0250 ksf, Tributary Width = 6.0 ft, (ROOF)

### DESIGN SUMMARY

**Design OK**

Maximum Bending Stress Ratio	=	<b>0.470</b>	1	Maximum Shear Stress Ratio	=	<b>0.182</b>	: 1
Section used for this span	=	<b>5.5x9</b>		Section used for this span	=	<b>5.5x9</b>	
	=	1,296.70psi			=	55.46 psi	
	=	2,760.00psi			=	304.75 psi	
Load Combination	=	<b>+D+S+H</b>		Load Combination	=	<b>+D+S+H</b>	
Location of maximum on span	=	<b>8.000ft</b>		Location of maximum on span	=	<b>15.299 ft</b>	
Span # where maximum occurs	=	<b>Span # 1</b>		Span # where maximum occurs	=	<b>Span # 1</b>	
<b>Maximum Deflection</b>							
Max Downward Transient Deflection		<b>0.370 in</b>	Ratio =	<b>519</b>	>=	<b>360</b>	
Max Upward Transient Deflection		<b>0.000 in</b>	Ratio =	<b>0</b>	<	<b>360</b>	
Max Downward Total Deflection		<b>0.618 in</b>	Ratio =	<b>310</b>	>=	<b>240</b>	
Max Upward Total Deflection		<b>0.000 in</b>	Ratio =	<b>0</b>	<	<b>240</b>	

### Maximum Forces & Stresses for Load Combinations

Load Combination	Segment Length	Span #	Max Stress Ratios									Moment Values			Shear Values						
			M	V	C <sub>d</sub>	C <sub>F/V</sub>	C <sub>i</sub>	C <sub>r</sub>	C <sub>m</sub>	C <sub>t</sub>	C <sub>L</sub>	M	fb	F'b	V	fv	F'v				
+D+H	Length = 16.0 ft	1	0.241	0.093	0.90	1.000	1.00	1.00	1.00	1.00	1.00	1.00	3.22	520.94	2160.00	0.00	0.00	0.00	0.74	22.28	238.50
+D+L+H	Length = 16.0 ft	1	0.217	0.084	1.00	1.000	1.00	1.00	1.00	1.00	1.00	1.00	3.22	520.94	2400.00	0.00	0.00	0.00	0.00	0.00	0.00
+D+Lr+H	Length = 16.0 ft	1	0.174	0.067	1.25	1.000	1.00	1.00	1.00	1.00	1.00	1.00	3.22	520.94	3000.00	0.00	0.00	0.00	0.74	22.28	331.25
+D+S+H	Length = 16.0 ft	1	0.470	0.182	1.15	1.000	1.00	1.00	1.00	1.00	1.00	1.00	8.02	1,296.70	2760.00	0.00	0.00	0.00	1.83	55.46	304.75
+D+0.750Lr+0.750L+H	Length = 16.0 ft	1	0.174	0.067	1.25	1.000	1.00	1.00	1.00	1.00	1.00	1.00	3.22	520.94	3000.00	0.00	0.00	0.00	0.74	22.28	331.25
+D+0.750L+0.750S+H	Length = 16.0 ft	1	0.400	0.155	1.15	1.000	1.00	1.00	1.00	1.00	1.00	1.00	6.82	1,102.76	2760.00	0.00	0.00	0.00	1.56	47.16	304.75
+D+0.60W+H						1.000	1.00	1.00	1.00	1.00	1.00	1.00				0.00	0.00	0.00	0.00	0.00	0.00



**Wood Beam**

Lic. # : KW-06009431

**DESCRIPTIO HDR#8**

Load Combination	Segment Length	Span #	Max Stress Ratios									Moment Values			Shear Values		
			M	V	C <sub>d</sub>	C <sub>F/V</sub>	C <sub>i</sub>	C <sub>r</sub>	C <sub>m</sub>	C <sub>t</sub>	C <sub>L</sub>	M	fb	F'b	V	fv	Fv
Length = 16.0 ft	1	0.136	0.053	1.60	1.000	1.00	1.00	1.00	1.00	1.00	1.00	3.22	520.94	3840.00	0.74	22.28	424.00
+D+0.750Lr+0.750L+0.450W-					1.000	1.00	1.00	1.00	1.00	1.00	1.00			0.00	0.00	0.00	0.00
Length = 16.0 ft	1	0.136	0.053	1.60	1.000	1.00	1.00	1.00	1.00	1.00	1.00	3.22	520.94	3840.00	0.74	22.28	424.00
+D+0.750L+0.750S+0.450W+					1.000	1.00	1.00	1.00	1.00	1.00	1.00			0.00	0.00	0.00	0.00
Length = 16.0 ft	1	0.287	0.111	1.60	1.000	1.00	1.00	1.00	1.00	1.00	1.00	6.82	1,102.76	3840.00	1.56	47.16	424.00
+0.60D+0.60W+0.60H					1.000	1.00	1.00	1.00	1.00	1.00	1.00			0.00	0.00	0.00	0.00
Length = 16.0 ft	1	0.081	0.032	1.60	1.000	1.00	1.00	1.00	1.00	1.00	1.00	1.93	312.56	3840.00	0.44	13.37	424.00
+D+0.70E+0.60H					1.000	1.00	1.00	1.00	1.00	1.00	1.00			0.00	0.00	0.00	0.00
Length = 16.0 ft	1	0.136	0.053	1.60	1.000	1.00	1.00	1.00	1.00	1.00	1.00	3.22	520.94	3840.00	0.74	22.28	424.00
+D+0.750L+0.750S+0.5250E-					1.000	1.00	1.00	1.00	1.00	1.00	1.00			0.00	0.00	0.00	0.00
Length = 16.0 ft	1	0.287	0.111	1.60	1.000	1.00	1.00	1.00	1.00	1.00	1.00	6.82	1,102.76	3840.00	1.56	47.16	424.00
+0.60D+0.70E+H					1.000	1.00	1.00	1.00	1.00	1.00	1.00			0.00	0.00	0.00	0.00
Length = 16.0 ft	1	0.081	0.032	1.60	1.000	1.00	1.00	1.00	1.00	1.00	1.00	1.93	312.56	3840.00	0.44	13.37	424.00

**Overall Maximum Deflections**

Load Combination	Span	Max. "-" Defl	Location in Span	Load Combination	Max. "+" Defl	Location in Span
+D+S+H	1	0.6183	8.058		0.0000	0.000

**Vertical Reactions**

Support notation : Far left is #'

Values in KIPS

Load Combination	Support 1	Support 2
Overall MAXimum	2.006	2.006
Overall MINimum	1.200	1.200
+D+H	0.806	0.806
+D+L+H	0.806	0.806
+D+Lr+H	0.806	0.806
+D+S+H	2.006	2.006
+D+0.750Lr+0.750L+H	0.806	0.806
+D+0.750L+0.750S+H	1.706	1.706
+D+0.60W+H	0.806	0.806
+D+0.750Lr+0.750L+0.450W+H	0.806	0.806
+D+0.750L+0.750S+0.450W+H	1.706	1.706
+0.60D+0.60W+0.60H	0.483	0.483
+D+0.70E+0.60H	0.806	0.806
+D+0.750L+0.750S+0.5250E+H	1.706	1.706
+0.60D+0.70E+H	0.483	0.483
D Only	0.806	0.806
Lr Only		
L Only		
S Only	1.200	1.200
W Only		
E Only		
H Only		

## Wood Beam

Lic. # : KW-06009431

### DESCRIPTIO HDR#9

### CODE REFERENCES

Calculations per NDS 2015, IBC 2015, CBC 2016, ASCE 7-10  
Load Combination Set : ASCE 7-16

### Material Properties

Analysis Method	Allowable Stress Design	Fb +	2,400.0 psi	E : Modulus of Elasti	
Load Combination	ASCE 7-16	Fb -	1,850.0 psi	Ebend- xx	1,800.0ksi
Wood Species	DF/DF	Fc - Prll	1,650.0 psi	Eminbend - x	950.0ksi
Wood Grade	24F - V4	Fc - Perp	650.0 psi	Ebend- yy	1,600.0ksi
		Fv	265.0 psi	Eminbend - y	850.0ksi
		Ft	1,100.0 psi	Density	31.210pcf
Beam Bracing	Beam is Fully Braced against lateral-torsional buckling				

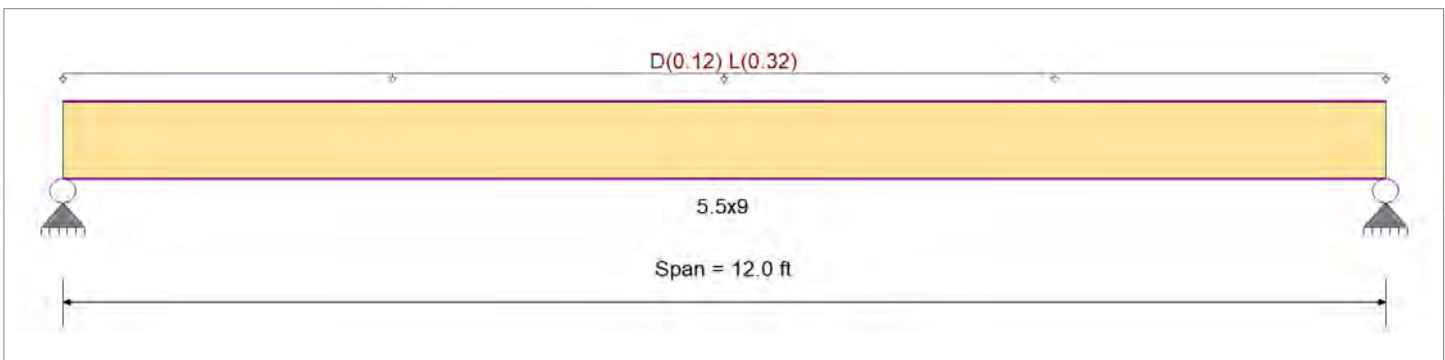

### Applied Loads

Service loads entered. Load Factors will be applied for calculations.

Beam self weight calculated and added to loads

Uniform Load : D = 0.0150, L = 0.040 ksf, Tributary Width = 8.0 ft, (FLOOR)

### DESIGN SUMMARY

**Design OK**

Maximum Bending Stress Ratio	=	<b>0.546</b>	1	Maximum Shear Stress Ratio	=	<b>0.271</b>	: 1
Section used for this span	=	<b>5.5x9</b>		Section used for this span	=	<b>5.5x9</b>	
	=	1,311.21 psi			=	71.78 psi	
	=	2,400.00 psi			=	265.00 psi	
Load Combination	=	<b>+D+L+H</b>		Load Combination	=	<b>+D+L+H</b>	
Location of maximum on span	=	<b>6.000</b> ft		Location of maximum on span	=	<b>6.000</b> ft	
Span # where maximum occurs	=	<b>Span # 1</b>		Span # where maximum occurs	=	<b>Span # 1</b>	
<b>Maximum Deflection</b>							
Max Downward Transient Deflection		<b>0.250</b> in	Ratio =	<b>576</b>	>=	<b>360</b>	
Max Upward Transient Deflection		<b>0.000</b> in	Ratio =	<b>0</b>	<	<b>360</b>	
Max Downward Total Deflection		<b>0.352</b> in	Ratio =	<b>409</b>	>=	<b>240</b>	
Max Upward Total Deflection		<b>0.000</b> in	Ratio =	<b>0</b>	<	<b>240</b>	

### Maximum Forces & Stresses for Load Combinations

Load Combination	Segment Length	Span #	Max Stress Ratios									Moment Values			Shear Values								
			M	V	C <sub>d</sub>	C <sub>F/V</sub>	C <sub>i</sub>	C <sub>r</sub>	C <sub>m</sub>	C <sub>t</sub>	C <sub>L</sub>	M	fb	F'b	V	fv	F'v						
+D+H	Length = 12.0 ft	1	0.176	0.087	0.90	1.000	1.00	1.00	1.00	1.00	1.00	1.00	1.00	2.35	380.30	2160.00	0.00	0.00	0.00	0.69	20.82	238.50	
+D+L+H	Length = 12.0 ft	1	0.546	0.271	1.00	1.000	1.00	1.00	1.00	1.00	1.00	1.00	1.00	8.11	1,311.21	2400.00	0.00	0.00	0.00	0.00	0.00	0.00	265.00
+D+Lr+H	Length = 12.0 ft	1	0.127	0.063	1.25	1.000	1.00	1.00	1.00	1.00	1.00	1.00	1.00	2.35	380.30	3000.00	0.00	0.00	0.00	0.69	20.82	331.25	
+D+S+H	Length = 12.0 ft	1	0.138	0.068	1.15	1.000	1.00	1.00	1.00	1.00	1.00	1.00	1.00	2.35	380.30	2760.00	0.00	0.00	0.00	0.69	20.82	304.75	
+D+0.750Lr+0.750L+H	Length = 12.0 ft	1	0.359	0.178	1.25	1.000	1.00	1.00	1.00	1.00	1.00	1.00	1.00	6.67	1,078.48	3000.00	0.00	0.00	0.00	1.95	59.04	331.25	
+D+0.750L+0.750S+H	Length = 12.0 ft	1	0.391	0.194	1.15	1.000	1.00	1.00	1.00	1.00	1.00	1.00	1.00	6.67	1,078.48	2760.00	0.00	0.00	0.00	1.95	59.04	304.75	
+D+0.60W+H						1.000	1.00	1.00	1.00	1.00	1.00	1.00	1.00			0.00	0.00	0.00	0.00	0.00	0.00	0.00	

**Wood Beam**

Lic. # : KW-06009431

**DESCRIPTIO HDR#9**

Load Combination	Segment Length	Span #	Max Stress Ratios									Moment Values			Shear Values		
			M	V	C <sub>d</sub>	C <sub>F/V</sub>	C <sub>i</sub>	C <sub>r</sub>	C <sub>m</sub>	C <sub>t</sub>	C <sub>L</sub>	M	fb	F'b	V	fv	F'v
Length = 12.0 ft	1	0.099	0.049	1.60	1.000	1.00	1.00	1.00	1.00	1.00	1.00	2.35	380.30	3840.00	0.69	20.82	424.00
+D+0.750Lr+0.750L+0.450W-					1.000	1.00	1.00	1.00	1.00	1.00	1.00			0.00	0.00	0.00	0.00
Length = 12.0 ft	1	0.281	0.139	1.60	1.000	1.00	1.00	1.00	1.00	1.00	1.00	6.67	1,078.48	3840.00	1.95	59.04	424.00
+D+0.750L+0.750S+0.450W+					1.000	1.00	1.00	1.00	1.00	1.00	1.00			0.00	0.00	0.00	0.00
Length = 12.0 ft	1	0.281	0.139	1.60	1.000	1.00	1.00	1.00	1.00	1.00	1.00	6.67	1,078.48	3840.00	1.95	59.04	424.00
+0.60D+0.60W+0.60H					1.000	1.00	1.00	1.00	1.00	1.00	1.00			0.00	0.00	0.00	0.00
Length = 12.0 ft	1	0.059	0.029	1.60	1.000	1.00	1.00	1.00	1.00	1.00	1.00	1.41	228.18	3840.00	0.41	12.49	424.00
+D+0.70E+0.60H					1.000	1.00	1.00	1.00	1.00	1.00	1.00			0.00	0.00	0.00	0.00
Length = 12.0 ft	1	0.099	0.049	1.60	1.000	1.00	1.00	1.00	1.00	1.00	1.00	2.35	380.30	3840.00	0.69	20.82	424.00
+D+0.750L+0.750S+0.5250E-					1.000	1.00	1.00	1.00	1.00	1.00	1.00			0.00	0.00	0.00	0.00
Length = 12.0 ft	1	0.281	0.139	1.60	1.000	1.00	1.00	1.00	1.00	1.00	1.00	6.67	1,078.48	3840.00	1.95	59.04	424.00
+0.60D+0.70E+H					1.000	1.00	1.00	1.00	1.00	1.00	1.00			0.00	0.00	0.00	0.00
Length = 12.0 ft	1	0.059	0.029	1.60	1.000	1.00	1.00	1.00	1.00	1.00	1.00	1.41	228.18	3840.00	0.41	12.49	424.00

**Overall Maximum Deflections**

Load Combination	Span	Max. "-" Defl	Location in Span	Load Combination	Max. "+" Defl	Location in Span
+D+L+H	1	0.3517	6.044		0.0000	0.000

**Vertical Reactions**

Support notation : Far left is #'

Values in KIPS

Load Combination	Support 1	Support 2
Overall MAXimum	2.704	2.704
Overall MINimum	1.920	1.920
+D+H	0.784	0.784
+D+L+H	2.704	2.704
+D+Lr+H	0.784	0.784
+D+S+H	0.784	0.784
+D+0.750Lr+0.750L+H	2.224	2.224
+D+0.750L+0.750S+H	2.224	2.224
+D+0.60W+H	0.784	0.784
+D+0.750Lr+0.750L+0.450W+H	2.224	2.224
+D+0.750L+0.750S+0.450W+H	2.224	2.224
+0.60D+0.60W+0.60H	0.471	0.471
+D+0.70E+0.60H	0.784	0.784
+D+0.750L+0.750S+0.5250E+H	2.224	2.224
+0.60D+0.70E+H	0.471	0.471
D Only	0.784	0.784
Lr Only		
L Only	1.920	1.920
S Only		
W Only		
E Only		
H Only		

**Wood Beam**

Lic. # : KW-06009431

**DESCRIPTIO HDR#10**

**CODE REFERENCES**

Calculations per NDS 2015, IBC 2015, CBC 2016, ASCE 7-10  
 Load Combination Set : ASCE 7-16

**Material Properties**

Analysis Method	Allowable Stress Design	Fb +	850 psi	E : Modulus of Elasticity	
Load Combination	ASCE 7-16	Fb -	850 psi	Ebend- xx	1300ksi
Wood Species	Hem Fir	Fc - Prll	1300 psi	Eminbend - x	470ksi
Wood Grade	No.2	Fc - Perp	405 psi		
		Fv	150 psi		
		Ft	525 psi	Density	26.84pcf
Beam Bracing	Beam is Fully Braced against lateral-torsional buckling				

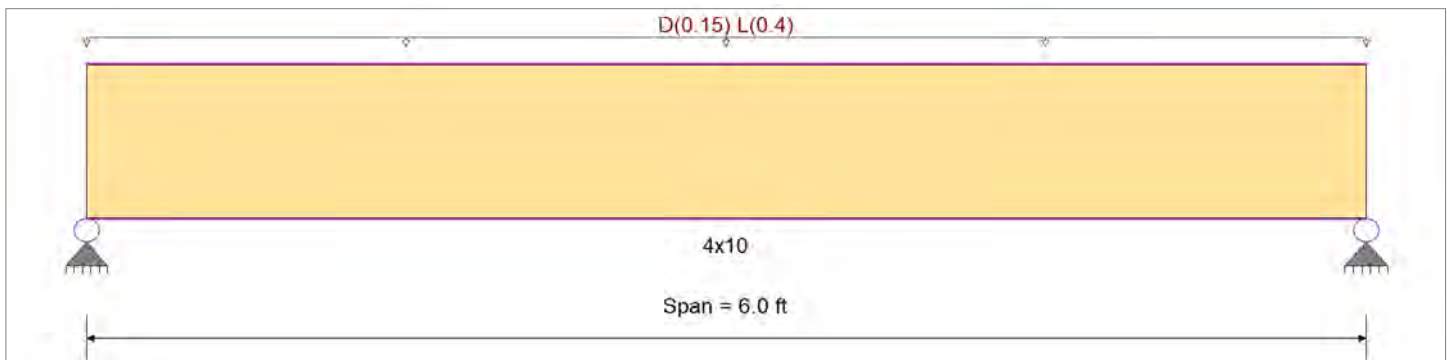

**Applied Loads**

Service loads entered. Load Factors will be applied for calculations.

Beam self weight calculated and added to loads

Uniform Load : D = 0.0150, L = 0.040 ksf, Tributary Width = 10.0 ft, (FLOOR)

**DESIGN SUMMARY**

**Design OK**

Maximum Bending Stress Ratio	=	<b>0.590</b> : 1	Maximum Shear Stress Ratio	=	<b>0.384</b> : 1
Section used for this span	=	<b>4x10</b>	Section used for this span	=	<b>4x10</b>
	=	601.58psi		=	57.54 psi
	=	1,020.00psi		=	150.00 psi
Load Combination	=	<b>+D+L+H</b>	Load Combination	=	<b>+D+L+H</b>
Location of maximum on span	=	<b>3.000ft</b>	Location of maximum on span	=	<b>0.000ft</b>
Span # where maximum occurs	=	<b>Span # 1</b>	Span # where maximum occurs	=	<b>Span # 1</b>
<b>Maximum Deflection</b>					
Max Downward Transient Deflection		<b>0.039</b> in	Ratio =	<b>1841</b>	<b>&gt;=360</b>
Max Upward Transient Deflection		<b>0.000</b> in	Ratio =	<b>0</b>	<b>&lt;360</b>
Max Downward Total Deflection		<b>0.054</b> in	Ratio =	<b>1324</b>	<b>&gt;=240</b>
Max Upward Total Deflection		<b>0.000</b> in	Ratio =	<b>0</b>	<b>&lt;240</b>

**Maximum Forces & Stresses for Load Combinations**

Load Combination	Segment Length	Span #	Max Stress Ratios									Moment Values			Shear Values								
			M	V	C <sub>d</sub>	C <sub>F/V</sub>	C <sub>i</sub>	C <sub>r</sub>	C <sub>m</sub>	C <sub>t</sub>	C <sub>L</sub>	M	fb	F'b	V	fv	F'v						
+D+H	Length = 6.0 ft	1	0.184	0.120	0.90	1.200	1.00	1.00	1.00	1.00	1.00	1.00	1.00	0.70	168.82	918.00	0.00	0.00	0.00	0.35	16.15	135.00	
+D+L+H	Length = 6.0 ft	1	0.590	0.384	1.00	1.200	1.00	1.00	1.00	1.00	1.00	1.00	1.00	2.50	601.58	1020.00	0.00	0.00	0.00	0.00	0.00	0.00	150.00
+D+Lr+H	Length = 6.0 ft	1	0.132	0.086	1.25	1.200	1.00	1.00	1.00	1.00	1.00	1.00	1.00	0.70	168.82	1275.00	0.00	0.00	0.00	0.35	16.15	187.50	
+D+S+H	Length = 6.0 ft	1	0.144	0.094	1.15	1.200	1.00	1.00	1.00	1.00	1.00	1.00	1.00	0.70	168.82	1173.00	0.00	0.00	0.00	0.35	16.15	172.50	
+D+0.750Lr+0.750L+H	Length = 6.0 ft	1	0.387	0.252	1.25	1.200	1.00	1.00	1.00	1.00	1.00	1.00	1.00	2.05	493.39	1275.00	0.00	0.00	0.00	1.02	47.19	187.50	
+D+0.750L+0.750S+H	Length = 6.0 ft	1	0.421	0.274	1.15	1.200	1.00	1.00	1.00	1.00	1.00	1.00	1.00	2.05	493.39	1173.00	0.00	0.00	0.00	1.02	47.19	172.50	
+D+0.60W+H						1.200	1.00	1.00	1.00	1.00	1.00	1.00	1.00			0.00			0.00	0.00	0.00	0.00	



**Wood Beam**

Lic. # : KW-06009431

**DESCRIPTIO HDR#10**

Load Combination	Segment Length	Span #	Max Stress Ratios									Moment Values			Shear Values		
			M	V	C <sub>d</sub>	C <sub>F/V</sub>	C <sub>i</sub>	C <sub>r</sub>	C <sub>m</sub>	C <sub>t</sub>	C <sub>L</sub>	M	fb	F'b	V	fv	Fv
Length = 6.0 ft	1	0.103	0.067	1.60	1.200	1.00	1.00	1.00	1.00	1.00	1.00	0.70	168.82	1632.00	0.35	16.15	240.00
+D+0.750Lr+0.750L+0.450W-					1.200	1.00	1.00	1.00	1.00	1.00	1.00			0.00	0.00	0.00	0.00
Length = 6.0 ft	1	0.302	0.197	1.60	1.200	1.00	1.00	1.00	1.00	1.00	1.00	2.05	493.39	1632.00	1.02	47.19	240.00
+D+0.750L+0.750S+0.450W+					1.200	1.00	1.00	1.00	1.00	1.00	1.00			0.00	0.00	0.00	0.00
Length = 6.0 ft	1	0.302	0.197	1.60	1.200	1.00	1.00	1.00	1.00	1.00	1.00	2.05	493.39	1632.00	1.02	47.19	240.00
+0.60D+0.60W+0.60H					1.200	1.00	1.00	1.00	1.00	1.00	1.00			0.00	0.00	0.00	0.00
Length = 6.0 ft	1	0.062	0.040	1.60	1.200	1.00	1.00	1.00	1.00	1.00	1.00	0.42	101.29	1632.00	0.21	9.69	240.00
+D+0.70E+0.60H					1.200	1.00	1.00	1.00	1.00	1.00	1.00			0.00	0.00	0.00	0.00
Length = 6.0 ft	1	0.103	0.067	1.60	1.200	1.00	1.00	1.00	1.00	1.00	1.00	0.70	168.82	1632.00	0.35	16.15	240.00
+D+0.750L+0.750S+0.5250E-					1.200	1.00	1.00	1.00	1.00	1.00	1.00			0.00	0.00	0.00	0.00
Length = 6.0 ft	1	0.302	0.197	1.60	1.200	1.00	1.00	1.00	1.00	1.00	1.00	2.05	493.39	1632.00	1.02	47.19	240.00
+0.60D+0.70E+H					1.200	1.00	1.00	1.00	1.00	1.00	1.00			0.00	0.00	0.00	0.00
Length = 6.0 ft	1	0.062	0.040	1.60	1.200	1.00	1.00	1.00	1.00	1.00	1.00	0.42	101.29	1632.00	0.21	9.69	240.00

**Overall Maximum Deflections**

Load Combination	Span	Max. "-" Defl	Location in Span	Load Combination	Max. "+" Defl	Location in Span
+D+L+H	1	0.0543	3.022		0.0000	0.000

**Vertical Reactions**

Support notation : Far left is #'

Values in KIPS

Load Combination	Support 1	Support 2
Overall MAXimum	1.668	1.668
Overall MINimum	1.200	1.200
+D+H	0.468	0.468
+D+L+H	1.668	1.668
+D+Lr+H	0.468	0.468
+D+S+H	0.468	0.468
+D+0.750Lr+0.750L+H	1.368	1.368
+D+0.750L+0.750S+H	1.368	1.368
+D+0.60W+H	0.468	0.468
+D+0.750Lr+0.750L+0.450W+H	1.368	1.368
+D+0.750L+0.750S+0.450W+H	1.368	1.368
+0.60D+0.60W+0.60H	0.281	0.281
+D+0.70E+0.60H	0.468	0.468
+D+0.750L+0.750S+0.5250E+H	1.368	1.368
+0.60D+0.70E+H	0.281	0.281
D Only	0.468	0.468
Lr Only		
L Only	1.200	1.200
S Only		
W Only		
E Only		
H Only		

**Wood Beam**

Lic. # : KW-06009431

**DESCRIPTIO HDR#11**

**CODE REFERENCES**

Calculations per NDS 2015, IBC 2015, CBC 2016, ASCE 7-10  
 Load Combination Set : ASCE 7-16

**Material Properties**

Analysis Method	Allowable Stress Design	Fb +	2900 psi	E : Modulus of Elasticity	
Load Combination	ASCE 7-16	Fb -	2900 psi	Ebend- xx	2000ksi
		Fc - Prll	2900 psi	Eminbend - x	1016.535ksi
Wood Species	Trus Joist	Fc - Perp	625 psi		
Wood Grade	Parallam PSL 2.0E	Fv	290 psi		
		Ft	2025 psi	Density	45.07pcf
Beam Bracing	Beam is Fully Braced against lateral-torsional buckling				

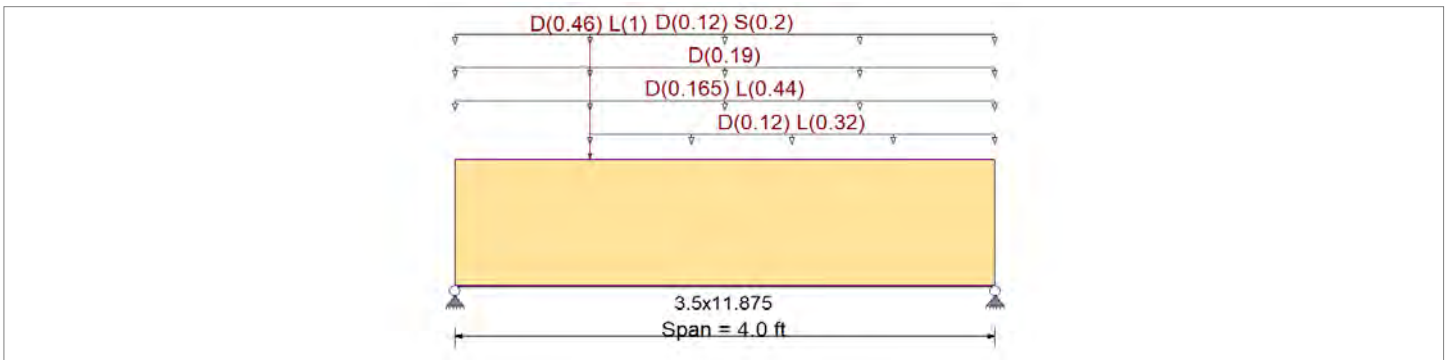

**Applied Loads**

Service loads entered. Load Factors will be applied for calculations.

Beam self weight calculated and added to loads  
 Load for Span Number 1

- Uniform Load : D = 0.0150, L = 0.040 ksf, Extent = 1.0 --> 4.0 ft, Tributary Width = 8.0 ft, (MAIN FLOOR)
- Uniform Load : D = 0.0150, L = 0.040 ksf, Tributary Width = 11.0 ft, (UPPER FLOOR)
- Uniform Load : D = 0.010 ksf, Tributary Width = 19.0 ft, (WALL)
- Uniform Load : D = 0.0150, S = 0.0250 ksf, Tributary Width = 8.0 ft, (ROOF)
- Point Load : D = 0.460, L = 1.0 k @ 1.0 ft, (BM#14)

**DESIGN SUMMARY**

**Design OK**

Maximum Bending Stress Ratio	=	<b>0.171</b> : 1	Maximum Shear Stress Ratio	=	<b>0.316</b> : 1
Section used for this span	=	<b>3.5x11.875</b>	Section used for this span	=	<b>3.5x11.875</b>
	=	494.70psi		=	91.61 psi
	=	2,900.00psi		=	290.00 psi
Load Combination	=	<b>+D+L+H</b>	Load Combination	=	<b>+D+L+H</b>
Location of maximum on span	=	1.766ft	Location of maximum on span	=	0.000ft
Span # where maximum occurs	=	<b>Span # 1</b>	Span # where maximum occurs	=	<b>Span # 1</b>
<b>Maximum Deflection</b>					
Max Downward Transient Deflection		0.006 in	Ratio =	<b>8174</b>	<b>&gt;=360</b>
Max Upward Transient Deflection		0.000 in	Ratio =	<b>0</b>	<b>&lt;360</b>
Max Downward Total Deflection		0.010 in	Ratio =	<b>4739</b>	<b>&gt;=240</b>
Max Upward Total Deflection		0.000 in	Ratio =	<b>0</b>	<b>&lt;240</b>

**Maximum Forces & Stresses for Load Combinations**

Load Combination	Segment Length	Span #	Max Stress Ratios								Moment Values			Shear Values						
			M	V	C <sub>d</sub>	C <sub>F/V</sub>	C <sub>i</sub>	C <sub>r</sub>	C <sub>m</sub>	C <sub>t</sub>	C <sub>L</sub>	M	fb	F'b	V	fv	F'v			
+D+H	Length = 4.0 ft	1	0.080	0.135	0.90	1.000	1.00	1.00	1.00	1.00	1.00	1.42	207.77	2610.00	0.00	0.00	0.00	0.00	0.00	0.00
+D+L+H	Length = 4.0 ft	1	0.171	0.316	1.00	1.000	1.00	1.00	1.00	1.00	1.00	3.39	494.70	2900.00	0.00	0.00	0.00	2.54	91.61	290.00
+D+Lr+H	Length = 4.0 ft	1	0.057	0.097	1.25	1.000	1.00	1.00	1.00	1.00	1.00	1.42	207.77	3625.00	0.00	0.00	0.00	0.98	35.32	362.50
+D+S+H	Length = 4.0 ft	1	0.080	0.128	1.15	1.000	1.00	1.00	1.00	1.00	1.00	1.82	265.82	3335.00	0.00	0.00	0.00	1.18	42.70	333.50

**Wood Beam**

Lic. # : KW-06009431

**DESCRIPTIO HDR#11**

Load Combination	Segment Length	Span #	Max Stress Ratios								Moment Values			Shear Values							
			M	V	C <sub>d</sub>	C <sub>F/V</sub>	C <sub>i</sub>	C <sub>r</sub>	C <sub>m</sub>	C <sub>t</sub>	C <sub>L</sub>	M	fb	F'b	V	fv	Fv				
+D+0.750Lr+0.750L+H	Length = 4.0 ft	1	0.117	0.214	1.25	1.000	1.00	1.00	1.00	1.00	1.00	1.00	1.00	1.00	1.00	0.00	0.00	0.00	0.00	0.00	0.00
+D+0.750L+0.750S+H	Length = 4.0 ft	1	0.140	0.249	1.15	1.000	1.00	1.00	1.00	1.00	1.00	1.00	1.00	1.00	1.00	0.00	0.00	0.00	0.00	0.00	0.00
+D+0.60W+H	Length = 4.0 ft	1	0.045	0.076	1.60	1.000	1.00	1.00	1.00	1.00	1.00	1.00	1.00	1.00	1.00	0.00	0.00	0.00	0.00	0.00	0.00
+D+0.750Lr+0.750L+0.450W-	Length = 4.0 ft	1	0.091	0.167	1.60	1.000	1.00	1.00	1.00	1.00	1.00	1.00	1.00	1.00	1.00	0.00	0.00	0.00	0.00	0.00	0.00
+D+0.750L+0.750S+0.450W+	Length = 4.0 ft	1	0.100	0.179	1.60	1.000	1.00	1.00	1.00	1.00	1.00	1.00	1.00	1.00	1.00	0.00	0.00	0.00	0.00	0.00	0.00
+0.60D+0.60W+0.60H	Length = 4.0 ft	1	0.027	0.046	1.60	1.000	1.00	1.00	1.00	1.00	1.00	1.00	1.00	1.00	1.00	0.00	0.00	0.00	0.00	0.00	0.00
+D+0.70E+0.60H	Length = 4.0 ft	1	0.045	0.076	1.60	1.000	1.00	1.00	1.00	1.00	1.00	1.00	1.00	1.00	1.00	0.00	0.00	0.00	0.00	0.00	0.00
+D+0.750L+0.750S+0.5250E-	Length = 4.0 ft	1	0.100	0.179	1.60	1.000	1.00	1.00	1.00	1.00	1.00	1.00	1.00	1.00	1.00	0.00	0.00	0.00	0.00	0.00	0.00
+0.60D+0.70E+H	Length = 4.0 ft	1	0.027	0.046	1.60	1.000	1.00	1.00	1.00	1.00	1.00	1.00	1.00	1.00	1.00	0.00	0.00	0.00	0.00	0.00	0.00

**Overall Maximum Deflections**

Load Combination	Span	Max. "-" Defl	Location in Span	Load Combination	Max. "+" Defl	Location in Span
+D+L+H	1	0.0101	1.956		0.0000	0.000

**Vertical Reactions**

Load Combination	Support notation : Far left is #'		Values in KIPS	
	Support 1	Support 2		
Overall MAXimum	3.446	3.046		
Overall MINimum	0.400	0.400		
+D+H	1.456	1.316		
+D+L+H	3.446	3.046		
+D+Lr+H	1.456	1.316		
+D+S+H	1.856	1.716		
+D+0.750Lr+0.750L+H	2.949	2.614		
+D+0.750L+0.750S+H	3.249	2.914		
+D+0.60W+H	1.456	1.316		
+D+0.750Lr+0.750L+0.450W+H	2.949	2.614		
+D+0.750L+0.750S+0.450W+H	3.249	2.914		
+0.60D+0.60W+0.60H	0.874	0.790		
+D+0.70E+0.60H	1.456	1.316		
+D+0.750L+0.750S+0.5250E+H	3.249	2.914		
+0.60D+0.70E+H	0.874	0.790		
D Only	1.456	1.316		
Lr Only				
L Only	1.990	1.730		
S Only	0.400	0.400		
W Only				
E Only				
H Only				

## Wood Beam

Lic. #: KW-06009431

### DESCRIPTIO BM#1

### CODE REFERENCES

Calculations per NDS 2015, IBC 2015, CBC 2016, ASCE 7-10  
Load Combination Set : ASCE 7-16

### Material Properties

Analysis Method	Allowable Stress Design	Fb +	850 psi	E : Modulus of Elasticity	
Load Combination	ASCE 7-16	Fb -	850 psi	Ebend- xx	1600ksi
		Fc - Prll	1400 psi	Eminbend - x	580ksi
Wood Species	Douglas Fir - Larch (North)	Fc - Perp	625 psi		
Wood Grade	No. 1/No. 2	Fv	180 psi		
		Ft	500 psi	Density	30.59pcf
Beam Bracing	Beam is Fully Braced against lateral-torsional buckling				

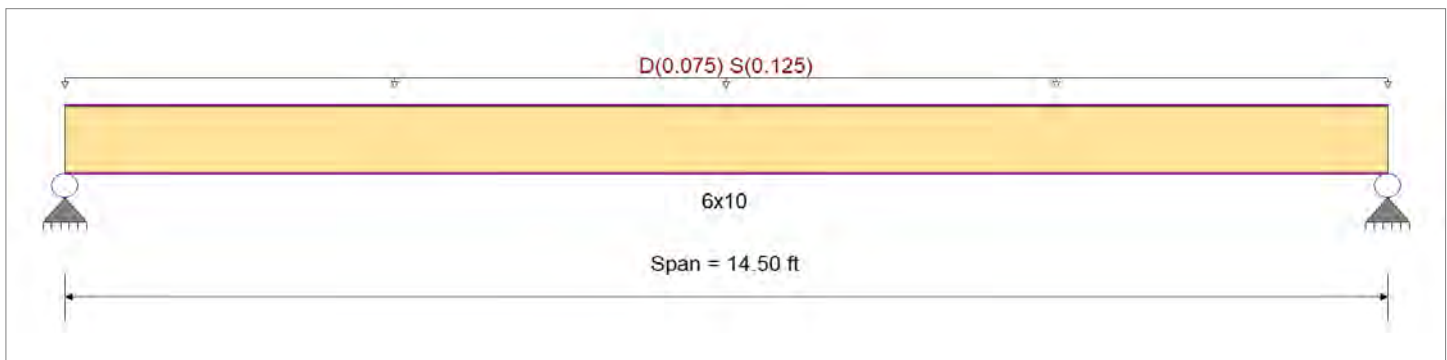

### Applied Loads

Service loads entered. Load Factors will be applied for calculations.

Beam self weight calculated and added to loads

Uniform Load : D = 0.0150, S = 0.0250 ksf, Tributary Width = 5.0 ft, (ROOF)

### DESIGN SUMMARY

**Design OK**

Maximum Bending Stress Ratio	=	<b>0.823</b> < 1	Maximum Shear Stress Ratio	=	<b>0.191</b> < 1
Section used for this span	=	<b>6x10</b>	Section used for this span	=	<b>6x10</b>
	=	804.74psi		=	39.45 psi
	=	977.50psi		=	207.00 psi
Load Combination	=	+D+S+H	Load Combination	=	+D+S+H
Location of maximum on span	=	7.250ft	Location of maximum on span	=	0.000ft
Span # where maximum occurs	=	Span # 1	Span # where maximum occurs	=	Span # 1
<b>Maximum Deflection</b>					
Max Downward Transient Deflection		0.199 in	Ratio =		874 >=360
Max Upward Transient Deflection		0.000 in	Ratio =		0 <360
Max Downward Total Deflection		0.336 in	Ratio =		518 >=240
Max Upward Total Deflection		0.000 in	Ratio =		0 <240

### Maximum Forces & Stresses for Load Combinations

Load Combination	Segment Length	Span #	Max Stress Ratios									Moment Values			Shear Values							
			M	V	C <sub>d</sub>	C <sub>F/V</sub>	C <sub>i</sub>	C <sub>r</sub>	C <sub>m</sub>	C <sub>t</sub>	C <sub>L</sub>	M	fb	F'b	V	fv	F'v					
+D+H	Length = 14.50 ft	1	0.429	0.099	0.90	1.000	1.00	1.00	1.00	1.00	1.00	1.00	1.00	2.26	328.22	765.00	0.00	0.00	0.00	0.56	16.09	162.00
+D+L+H	Length = 14.50 ft	1	0.386	0.089	1.00	1.000	1.00	1.00	1.00	1.00	1.00	1.00	1.00	2.26	328.22	850.00	0.00	0.00	0.00	0.00	0.00	180.00
+D+Lr+H	Length = 14.50 ft	1	0.309	0.072	1.25	1.000	1.00	1.00	1.00	1.00	1.00	1.00	1.00	2.26	328.22	1062.50	0.00	0.00	0.00	0.56	16.09	225.00
+D+S+H	Length = 14.50 ft	1	0.823	0.191	1.15	1.000	1.00	1.00	1.00	1.00	1.00	1.00	1.00	5.55	804.74	977.50	0.00	0.00	0.00	1.37	39.45	207.00
+D+0.750Lr+0.750L+H	Length = 14.50 ft	1	0.309	0.072	1.25	1.000	1.00	1.00	1.00	1.00	1.00	1.00	1.00	2.26	328.22	1062.50	0.00	0.00	0.00	0.56	16.09	225.00
+D+0.750L+0.750S+H	Length = 14.50 ft	1	0.701	0.162	1.15	1.000	1.00	1.00	1.00	1.00	1.00	1.00	1.00	4.73	685.61	977.50	0.00	0.00	0.00	1.17	33.61	207.00
+D+0.60W+H						1.000	1.00	1.00	1.00	1.00	1.00	1.00	1.00				0.00	0.00	0.00	0.00	0.00	0.00



**Wood Beam**

Lic. # : KW-06009431

**DESCRIPTIO BM#1**

Load Combination	Segment Length	Span #	Max Stress Ratios									Moment Values			Shear Values		
			M	V	C <sub>d</sub>	C <sub>F/V</sub>	C <sub>i</sub>	C <sub>r</sub>	C <sub>m</sub>	C <sub>t</sub>	C <sub>L</sub>	M	fb	F'b	V	fv	Fv
Length = 14.50 ft	1	0.241	0.056	1.60	1.000	1.00	1.00	1.00	1.00	1.00	1.00	2.26	328.22	1360.00	0.56	16.09	288.00
+D+0.750Lr+0.750L+0.450W-					1.000	1.00	1.00	1.00	1.00	1.00	1.00			0.00	0.00	0.00	0.00
Length = 14.50 ft	1	0.241	0.056	1.60	1.000	1.00	1.00	1.00	1.00	1.00	1.00	2.26	328.22	1360.00	0.56	16.09	288.00
+D+0.750L+0.750S+0.450W+					1.000	1.00	1.00	1.00	1.00	1.00	1.00			0.00	0.00	0.00	0.00
Length = 14.50 ft	1	0.504	0.117	1.60	1.000	1.00	1.00	1.00	1.00	1.00	1.00	4.73	685.61	1360.00	1.17	33.61	288.00
+0.60D+0.60W+0.60H					1.000	1.00	1.00	1.00	1.00	1.00	1.00			0.00	0.00	0.00	0.00
Length = 14.50 ft	1	0.145	0.034	1.60	1.000	1.00	1.00	1.00	1.00	1.00	1.00	1.36	196.93	1360.00	0.34	9.65	288.00
+D+0.70E+0.60H					1.000	1.00	1.00	1.00	1.00	1.00	1.00			0.00	0.00	0.00	0.00
Length = 14.50 ft	1	0.241	0.056	1.60	1.000	1.00	1.00	1.00	1.00	1.00	1.00	2.26	328.22	1360.00	0.56	16.09	288.00
+D+0.750L+0.750S+0.5250E-					1.000	1.00	1.00	1.00	1.00	1.00	1.00			0.00	0.00	0.00	0.00
Length = 14.50 ft	1	0.504	0.117	1.60	1.000	1.00	1.00	1.00	1.00	1.00	1.00	4.73	685.61	1360.00	1.17	33.61	288.00
+0.60D+0.70E+H					1.000	1.00	1.00	1.00	1.00	1.00	1.00			0.00	0.00	0.00	0.00
Length = 14.50 ft	1	0.145	0.034	1.60	1.000	1.00	1.00	1.00	1.00	1.00	1.00	1.36	196.93	1360.00	0.34	9.65	288.00

**Overall Maximum Deflections**

Load Combination	Span	Max. "-" Defl	Location in Span	Load Combination	Max. "+" Defl	Location in Span
+D+S+H	1	0.3359	7.303		0.0000	0.000

**Vertical Reactions**

Support notation : Far left is #'

Values in KIPS

Load Combination	Support 1	Support 2
Overall MAXimum	1.530	1.530
Overall MINimum	0.906	0.906
+D+H	0.624	0.624
+D+L+H	0.624	0.624
+D+Lr+H	0.624	0.624
+D+S+H	1.530	1.530
+D+0.750Lr+0.750L+H	0.624	0.624
+D+0.750L+0.750S+H	1.304	1.304
+D+0.60W+H	0.624	0.624
+D+0.750Lr+0.750L+0.450W+H	0.624	0.624
+D+0.750L+0.750S+0.450W+H	1.304	1.304
+0.60D+0.60W+0.60H	0.375	0.375
+D+0.70E+0.60H	0.624	0.624
+D+0.750L+0.750S+0.5250E+H	1.304	1.304
+0.60D+0.70E+H	0.375	0.375
D Only	0.624	0.624
Lr Only		
L Only		
S Only	0.906	0.906
W Only		
E Only		
H Only		

## Wood Beam

Lic. # : KW-06009431

### DESCRIPTIO BM#2

### CODE REFERENCES

Calculations per NDS 2015, IBC 2015, CBC 2016, ASCE 7-10  
Load Combination Set : ASCE 7-16

### Material Properties

Analysis Method	Allowable Stress Design	Fb +	850.0 psi	E : Modulus of Elasticity	
Load Combination	ASCE 7-16	Fb -	850.0 psi	Ebend- xx	1,600.0ksi
		Fc - Prll	1,400.0 psi	Eminbend - x	580.0ksi
Wood Species	Douglas Fir - Larch (North)	Fc - Perp	625.0 psi		
Wood Grade	No. 1/No. 2	Fv	180.0 psi		
		Ft	500.0 psi	Density	30.590pcf
Beam Bracing	Beam is Fully Braced against lateral-torsional buckling				

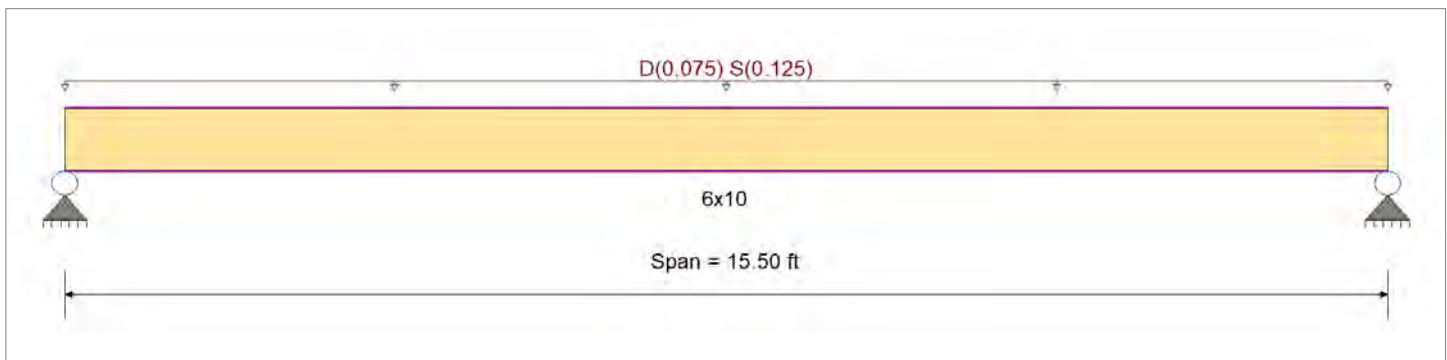

### Applied Loads

Service loads entered. Load Factors will be applied for calculations.

Beam self weight calculated and added to loads

Uniform Load : D = 0.0150, S = 0.0250 ksf, Tributary Width = 5.0 ft, (ROOF)

### DESIGN SUMMARY

**Design OK**

Maximum Bending Stress Ratio	=	<b>0.941</b> : 1	Maximum Shear Stress Ratio	=	<b>0.205</b> : 1
Section used for this span	=	<b>6x10</b>	Section used for this span	=	<b>6x10</b>
	=	919.57 psi		=	42.51 psi
	=	977.50 psi		=	207.00 psi
Load Combination	=	<b>+D+S+H</b>	Load Combination	=	<b>+D+S+H</b>
Location of maximum on span	=	<b>7.750</b> ft	Location of maximum on span	=	<b>14.765</b> ft
Span # where maximum occurs	=	<b>Span # 1</b>	Span # where maximum occurs	=	<b>Span # 1</b>
<b>Maximum Deflection</b>					
Max Downward Transient Deflection		<b>0.260</b> in	Ratio =	<b>716</b> >=360	
Max Upward Transient Deflection		<b>0.000</b> in	Ratio =	<b>0</b> <360	
Max Downward Total Deflection		<b>0.439</b> in	Ratio =	<b>424</b> >=240	
Max Upward Total Deflection		<b>0.000</b> in	Ratio =	<b>0</b> <240	

### Maximum Forces & Stresses for Load Combinations

Load Combination	Segment Length	Span #	Max Stress Ratios									Moment Values			Shear Values								
			M	V	C <sub>d</sub>	C <sub>F/V</sub>	C <sub>i</sub>	C <sub>r</sub>	C <sub>m</sub>	C <sub>t</sub>	C <sub>L</sub>	M	fb	F'b	V	fv	F'v						
+D+H	Length = 15.50 ft	1	0.490	0.107	0.90	1.000	1.00	1.00	1.00	1.00	1.00	1.00	1.00	2.59	375.06	765.00	0.00	0.00	0.00	0.60	17.34	162.00	
+D+L+H	Length = 15.50 ft	1	0.441	0.096	1.00	1.000	1.00	1.00	1.00	1.00	1.00	1.00	1.00	2.59	375.06	850.00	0.00	0.00	0.00	0.00	0.00	0.00	180.00
+D+Lr+H	Length = 15.50 ft	1	0.353	0.077	1.25	1.000	1.00	1.00	1.00	1.00	1.00	1.00	1.00	2.59	375.06	1062.50	0.00	0.00	0.00	0.60	17.34	225.00	
+D+S+H	Length = 15.50 ft	1	0.941	0.205	1.15	1.000	1.00	1.00	1.00	1.00	1.00	1.00	1.00	6.34	919.57	977.50	0.00	0.00	0.00	1.48	42.51	207.00	
+D+0.750Lr+0.750L+H	Length = 15.50 ft	1	0.353	0.077	1.25	1.000	1.00	1.00	1.00	1.00	1.00	1.00	1.00	2.59	375.06	1062.50	0.00	0.00	0.00	0.60	17.34	225.00	
+D+0.750L+0.750S+H	Length = 15.50 ft	1	0.801	0.175	1.15	1.000	1.00	1.00	1.00	1.00	1.00	1.00	1.00	5.40	783.44	977.50	0.00	0.00	0.00	1.26	36.22	207.00	
+D+0.60W+H						1.000	1.00	1.00	1.00	1.00	1.00	1.00	1.00				0.00	0.00	0.00	0.00	0.00	0.00	

**Wood Beam**

Lic. # : KW-06009431

**DESCRIPTIO BM#2**

Load Combination	Segment Length	Span #	Max Stress Ratios									Moment Values			Shear Values		
			M	V	C <sub>d</sub>	C <sub>F/V</sub>	C <sub>i</sub>	C <sub>r</sub>	C <sub>m</sub>	C <sub>t</sub>	C <sub>L</sub>	M	fb	F'b	V	fv	F'v
Length = 15.50 ft	1	0.276	0.060	1.60	1.000	1.00	1.00	1.00	1.00	1.00	1.00	2.59	375.06	1360.00	0.60	17.34	288.00
+D+0.750Lr+0.750L+0.450W-					1.000	1.00	1.00	1.00	1.00	1.00	1.00			0.00	0.00	0.00	0.00
Length = 15.50 ft	1	0.276	0.060	1.60	1.000	1.00	1.00	1.00	1.00	1.00	1.00	2.59	375.06	1360.00	0.60	17.34	288.00
+D+0.750L+0.750S+0.450W+					1.000	1.00	1.00	1.00	1.00	1.00	1.00			0.00	0.00	0.00	0.00
Length = 15.50 ft	1	0.576	0.126	1.60	1.000	1.00	1.00	1.00	1.00	1.00	1.00	5.40	783.44	1360.00	1.26	36.22	288.00
+0.60D+0.60W+0.60H					1.000	1.00	1.00	1.00	1.00	1.00	1.00			0.00	0.00	0.00	0.00
Length = 15.50 ft	1	0.165	0.036	1.60	1.000	1.00	1.00	1.00	1.00	1.00	1.00	1.55	225.03	1360.00	0.36	10.40	288.00
+D+0.70E+0.60H					1.000	1.00	1.00	1.00	1.00	1.00	1.00			0.00	0.00	0.00	0.00
Length = 15.50 ft	1	0.276	0.060	1.60	1.000	1.00	1.00	1.00	1.00	1.00	1.00	2.59	375.06	1360.00	0.60	17.34	288.00
+D+0.750L+0.750S+0.5250E-					1.000	1.00	1.00	1.00	1.00	1.00	1.00			0.00	0.00	0.00	0.00
Length = 15.50 ft	1	0.576	0.126	1.60	1.000	1.00	1.00	1.00	1.00	1.00	1.00	5.40	783.44	1360.00	1.26	36.22	288.00
+0.60D+0.70E+H					1.000	1.00	1.00	1.00	1.00	1.00	1.00			0.00	0.00	0.00	0.00
Length = 15.50 ft	1	0.165	0.036	1.60	1.000	1.00	1.00	1.00	1.00	1.00	1.00	1.55	225.03	1360.00	0.36	10.40	288.00

**Overall Maximum Deflections**

Load Combination	Span	Max. "-" Defl	Location in Span	Load Combination	Max. "+" Defl	Location in Span
+D+S+H	1	0.4386	7.807		0.0000	0.000

**Vertical Reactions**

Support notation : Far left is #'

Values in KIPS

Load Combination	Support 1	Support 2
Overall MAXimum	1.636	1.636
Overall MINimum	0.969	0.969
+D+H	0.667	0.667
+D+L+H	0.667	0.667
+D+Lr+H	0.667	0.667
+D+S+H	1.636	1.636
+D+0.750Lr+0.750L+H	0.667	0.667
+D+0.750L+0.750S+H	1.394	1.394
+D+0.60W+H	0.667	0.667
+D+0.750Lr+0.750L+0.450W+H	0.667	0.667
+D+0.750L+0.750S+0.450W+H	1.394	1.394
+0.60D+0.60W+0.60H	0.400	0.400
+D+0.70E+0.60H	0.667	0.667
+D+0.750L+0.750S+0.5250E+H	1.394	1.394
+0.60D+0.70E+H	0.400	0.400
D Only	0.667	0.667
Lr Only		
L Only		
S Only	0.969	0.969
W Only		
E Only		
H Only		

## Wood Beam

Lic. # : KW-06009431

### DESCRIPTIO BM#3

### CODE REFERENCES

Calculations per NDS 2015, IBC 2015, CBC 2016, ASCE 7-10  
Load Combination Set : ASCE 7-16

### Material Properties

Analysis Method	Allowable Stress Design	Fb +	2900 psi	E : Modulus of Elasticity	
Load Combination	ASCE 7-16	Fb -	2900 psi	Ebend- xx	2000ksi
		Fc - Prll	2900 psi	Eminbend - x	1016.535ksi
Wood Species	Trus Joist	Fc - Perp	625 psi		
Wood Grade	Parallam PSL 2.0E	Fv	290 psi		
		Ft	2025 psi	Density	45.07pcf
Beam Bracing	Beam is Fully Braced against lateral-torsional buckling				

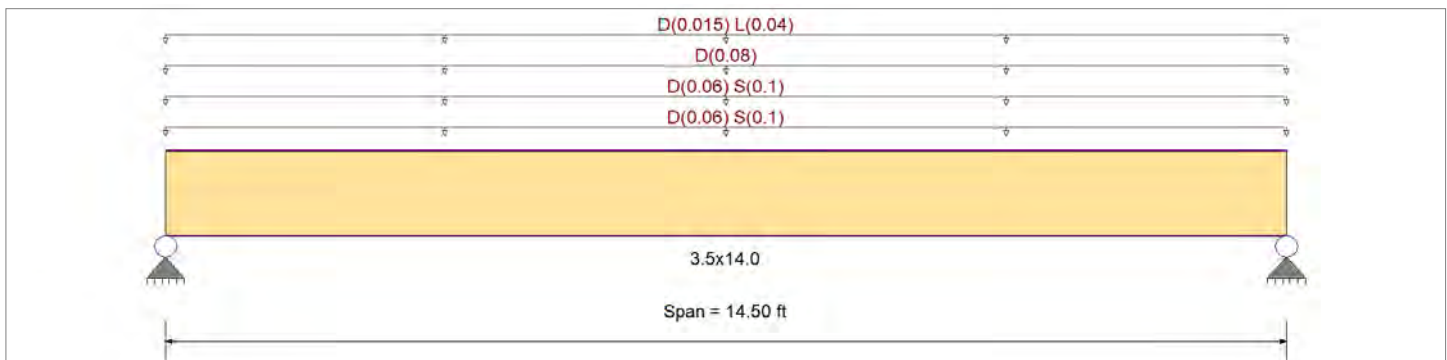

### Applied Loads

Service loads entered. Load Factors will be applied for calculations.

Beam self weight calculated and added to loads

- Uniform Load : D = 0.0150, S = 0.0250 ksf, Tributary Width = 4.0 ft, (UPPER ROOF)
- Uniform Load : D = 0.0150, S = 0.0250 ksf, Tributary Width = 4.0 ft, (LOWER ROOF)
- Uniform Load : D = 0.010 ksf, Tributary Width = 8.0 ft, (WALL)
- Uniform Load : D = 0.0150, L = 0.040 ksf, Tributary Width = 1.0 ft, (FLOOR)

### DESIGN SUMMARY

**Design OK**

Maximum Bending Stress Ratio	=	<b>0.356</b>	1	Maximum Shear Stress Ratio	=	<b>0.240</b>	: 1
Section used for this span	=	<b>3.5x14.0</b>		Section used for this span	=	<b>3.5x14.0</b>	
	=	1,187.03psi			=	80.17 psi	
	=	3,335.00psi			=	333.50 psi	
Load Combination	=	<b>+D+S+H</b>		Load Combination	=	<b>+D+S+H</b>	
Location of maximum on span	=	7.250ft		Location of maximum on span	=	0.000ft	
Span # where maximum occurs	=	Span # 1		Span # where maximum occurs	=	Span # 1	
<b>Maximum Deflection</b>							
Max Downward Transient Deflection		0.125 in	Ratio =	1391	>=	360	
Max Upward Transient Deflection		0.000 in	Ratio =	0	<	360	
Max Downward Total Deflection		0.269 in	Ratio =	646	>=	240	
Max Upward Total Deflection		0.000 in	Ratio =	0	<	240	

### Maximum Forces & Stresses for Load Combinations

Load Combination	Segment Length	Span #	Max Stress Ratios								Moment Values			Shear Values						
			M	V	C <sub>d</sub>	C <sub>F/V</sub>	C <sub>i</sub>	C <sub>r</sub>	C <sub>m</sub>	C <sub>t</sub>	C <sub>L</sub>	M	fb	F'b	V	fv	F'v			
+D+H	Length = 14.50 ft	1	0.243	0.164	0.90	1.000	1.00	1.00	1.00	1.00	1.00	6.05	635.36	2610.00	0.00	0.00	0.00	1.40	42.91	261.00
+D+L+H	Length = 14.50 ft	1	0.257	0.174	1.00	1.000	1.00	1.00	1.00	1.00	1.00	7.10	745.69	2900.00	0.00	0.00	0.00	0.00	0.00	0.00
+D+Lr+H	Length = 14.50 ft	1	0.175	0.118	1.25	1.000	1.00	1.00	1.00	1.00	1.00	6.05	635.36	3625.00	0.00	0.00	0.00	1.40	42.91	362.50
+D+S+H	Length = 14.50 ft	1	0.356	0.240	1.15	1.000	1.00	1.00	1.00	1.00	1.00	11.31	1,187.03	3335.00	0.00	0.00	0.00	2.62	80.17	333.50
+D+0.750Lr+0.750L+H	Length = 14.50 ft	1	0.198	0.134	1.25	1.000	1.00	1.00	1.00	1.00	1.00	6.84	718.11	3625.00	0.00	0.00	0.00	1.58	48.50	362.50



**Wood Beam**

Lic. # : KW-06009431

**DESCRIPTIO BM#3**

Load Combination Segment Length	Span #	Max Stress Ratios									Moment Values			Shear Values		
		M	V	C <sub>d</sub>	C <sub>F/V</sub>	C <sub>i</sub>	C <sub>r</sub>	C <sub>m</sub>	C <sub>t</sub>	C <sub>L</sub>	M	fb	F'b	V	fv	Fv
+D+0.750L+0.750S+H Length = 14.50 ft	1	0.339	0.229	1.15	1.000	1.00	1.00	1.00	1.00	1.00	10.78	1,131.86	3335.00	0.00	0.00	0.00
+D+0.60W+H Length = 14.50 ft	1	0.137	0.092	1.60	1.000	1.00	1.00	1.00	1.00	1.00	6.05	635.36	4640.00	0.00	0.00	0.00
+D+0.750Lr+0.750L+0.450W- Length = 14.50 ft	1	0.155	0.105	1.60	1.000	1.00	1.00	1.00	1.00	1.00	6.84	718.11	4640.00	0.00	0.00	0.00
+D+0.750L+0.750S+0.450W+ Length = 14.50 ft	1	0.244	0.165	1.60	1.000	1.00	1.00	1.00	1.00	1.00	10.78	1,131.86	4640.00	0.00	0.00	0.00
+0.60D+0.60W+0.60H Length = 14.50 ft	1	0.082	0.055	1.60	1.000	1.00	1.00	1.00	1.00	1.00	3.63	381.21	4640.00	0.00	0.00	0.00
+D+0.70E+0.60H Length = 14.50 ft	1	0.137	0.092	1.60	1.000	1.00	1.00	1.00	1.00	1.00	6.05	635.36	4640.00	0.00	0.00	0.00
+D+0.750L+0.750S+0.5250E- Length = 14.50 ft	1	0.244	0.165	1.60	1.000	1.00	1.00	1.00	1.00	1.00	10.78	1,131.86	4640.00	0.00	0.00	0.00
+0.60D+0.70E+H Length = 14.50 ft	1	0.082	0.055	1.60	1.000	1.00	1.00	1.00	1.00	1.00	3.63	381.21	4640.00	0.00	0.00	0.00

**Overall Maximum Deflections**

Load Combination	Span	Max. "-" Defl	Location in Span	Load Combination	Max. "+" Defl	Location in Span
+D+S+H	1	0.2690	7.303		0.0000	0.000

**Vertical Reactions**

Load Combination	Support notation : Far left is #'		Values in KIPS	
	Support 1	Support 2		
Overall MAXimum	3.120	3.120		
Overall MINimum	1.450	1.450		
+D+H	1.670	1.670		
+D+L+H	1.960	1.960		
+D+Lr+H	1.670	1.670		
+D+S+H	3.120	3.120		
+D+0.750Lr+0.750L+H	1.887	1.887		
+D+0.750L+0.750S+H	2.975	2.975		
+D+0.60W+H	1.670	1.670		
+D+0.750Lr+0.750L+0.450W+H	1.887	1.887		
+D+0.750L+0.750S+0.450W+H	2.975	2.975		
+0.60D+0.60W+0.60H	1.002	1.002		
+D+0.70E+0.60H	1.670	1.670		
+D+0.750L+0.750S+0.5250E+H	2.975	2.975		
+0.60D+0.70E+H	1.002	1.002		
D Only	1.670	1.670		
Lr Only				
L Only	0.290	0.290		
S Only	1.450	1.450		
W Only				
E Only				
H Only				

## Wood Beam

Lic. # : KW-06009431

### DESCRIPTIO BM#4

### CODE REFERENCES

Calculations per NDS 2015, IBC 2015, CBC 2016, ASCE 7-10  
Load Combination Set : ASCE 7-16

### Material Properties

Analysis Method	Allowable Stress Design	Fb +	2,900.0 psi	E : Modulus of Elasticity	
Load Combination	ASCE 7-16	Fb -	2,900.0 psi	Ebend- xx	2,000.0ksi
Wood Species	Trus Joist	Fc - Prll	2,900.0 psi	Eminbend - x	1,016.54ksi
Wood Grade	Parallam PSL 2.0E	Fc - Perp	625.0 psi		
		Fv	290.0 psi		
		Ft	2,025.0 psi	Density	45.070pcf
Beam Bracing	Beam is Fully Braced against lateral-torsional buckling				

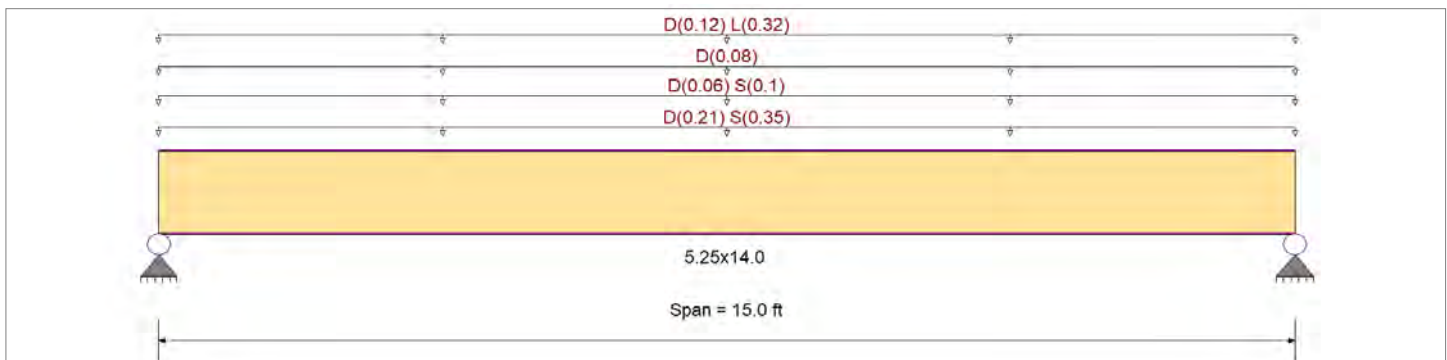

### Applied Loads

Service loads entered. Load Factors will be applied for calculations.

Beam self weight calculated and added to loads

- Uniform Load : D = 0.0150, S = 0.0250 ksf, Tributary Width = 14.0 ft, (UPPER ROOF)
- Uniform Load : D = 0.0150, S = 0.0250 ksf, Tributary Width = 4.0 ft, (LOWER ROOF)
- Uniform Load : D = 0.010 ksf, Tributary Width = 8.0 ft, (WALL)
- Uniform Load : D = 0.0150, L = 0.040 ksf, Tributary Width = 8.0 ft, (FLOOR)

### DESIGN SUMMARY

**Design OK**

Maximum Bending Stress Ratio	=	<b>0.643</b> < 1	Maximum Shear Stress Ratio	=	<b>0.416</b> < 1
Section used for this span		<b>5.25x14.0</b>	Section used for this span		<b>5.25x14.0</b>
	=	2,106.68psi		=	138.74 psi
	=	3,278.42psi		=	333.50 psi
Load Combination	+D+0.750L+0.750S+H		Load Combination	+D+0.750L+0.750S+H	
Location of maximum on span	=	7.500ft	Location of maximum on span	=	13.850 ft
Span # where maximum occurs	=	Span # 1	Span # where maximum occurs	=	Span # 1
<b>Maximum Deflection</b>					
Max Downward Transient Deflection		0.215 in	Ratio =	<b>838</b> >= 360	
Max Upward Transient Deflection		0.000 in	Ratio =	<b>0</b> < 360	
Max Downward Total Deflection		0.511 in	Ratio =	<b>352</b> >= 240	
Max Upward Total Deflection		0.000 in	Ratio =	<b>0</b> < 240	

### Maximum Forces & Stresses for Load Combinations

Load Combination	Segment Length	Span #	Max Stress Ratios								Moment Values			Shear Values						
			M	V	C <sub>d</sub>	C <sub>F/V</sub>	C <sub>i</sub>	C <sub>r</sub>	C <sub>m</sub>	C <sub>t</sub>	C <sub>L</sub>	M	fb	F'b	V	fv	F'v			
+D+H	Length = 15.0 ft	1	0.378	0.245	0.90	0.983	1.00	1.00	1.00	1.00	1.00	13.87	970.20	2565.72	0.00	0.00	0.00	0.00	0.00	261.00
+D+L+H	Length = 15.0 ft	1	0.561	0.363	1.00	0.983	1.00	1.00	1.00	1.00	1.00	22.87	1,599.94	2850.80	0.00	0.00	0.00	0.00	0.00	290.00
+D+Lr+H	Length = 15.0 ft	1	0.272	0.176	1.25	0.983	1.00	1.00	1.00	1.00	1.00	13.87	970.20	3563.50	0.00	0.00	0.00	0.00	0.00	362.50
+D+S+H	Length = 15.0 ft	1	0.566	0.366	1.15	0.983	1.00	1.00	1.00	1.00	1.00	26.52	1,855.77	3278.42	0.00	0.00	0.00	0.00	0.00	333.50
+D+0.750Lr+0.750L+H	Length = 15.0 ft	1	0.405	0.262	1.25	0.983	1.00	1.00	1.00	1.00	1.00	20.62	1,442.50	3563.50	0.00	0.00	0.00	0.00	0.00	362.50

**Wood Beam**

Lic. # : KW-06009431

**DESCRIPTIO BM#4**

Load Combination	Segment Length	Span #	Max Stress Ratios								Moment Values			Shear Values								
			M	V	C <sub>d</sub>	C <sub>F/V</sub>	C <sub>i</sub>	C <sub>r</sub>	C <sub>m</sub>	C <sub>t</sub>	C <sub>L</sub>	M	fb	F'b	V	f <sub>v</sub>	F <sub>v</sub>					
+D+0.750L+0.750S+H	Length = 15.0 ft	1	0.643	0.416	1.15	0.983	1.00	1.00	1.00	1.00	1.00	1.00	1.00	30.11	2,106.68	3278.42	0.00	0.00	0.00	6.80	138.74	333.50
+D+0.60W+H	Length = 15.0 ft	1	0.213	0.138	1.60	0.983	1.00	1.00	1.00	1.00	1.00	1.00	1.00	13.87	970.20	4561.28	0.00	0.00	0.00	0.00	0.00	0.00
+D+0.750Lr+0.750L+0.450W-	Length = 15.0 ft	1	0.316	0.205	1.60	0.983	1.00	1.00	1.00	1.00	1.00	1.00	1.00	20.62	1,442.50	4561.28	0.00	0.00	0.00	4.65	95.00	464.00
+D+0.750L+0.750S+0.450W+	Length = 15.0 ft	1	0.462	0.299	1.60	0.983	1.00	1.00	1.00	1.00	1.00	1.00	1.00	30.11	2,106.68	4561.28	0.00	0.00	0.00	6.80	138.74	464.00
+0.60D+0.60W+0.60H	Length = 15.0 ft	1	0.128	0.083	1.60	0.983	1.00	1.00	1.00	1.00	1.00	1.00	1.00	8.32	582.12	4561.28	0.00	0.00	0.00	1.88	38.34	464.00
+D+0.70E+0.60H	Length = 15.0 ft	1	0.213	0.138	1.60	0.983	1.00	1.00	1.00	1.00	1.00	1.00	1.00	13.87	970.20	4561.28	0.00	0.00	0.00	3.13	63.89	464.00
+D+0.750L+0.750S+0.5250E-	Length = 15.0 ft	1	0.462	0.299	1.60	0.983	1.00	1.00	1.00	1.00	1.00	1.00	1.00	30.11	2,106.68	4561.28	0.00	0.00	0.00	6.80	138.74	464.00
+0.60D+0.70E+H	Length = 15.0 ft	1	0.128	0.083	1.60	0.983	1.00	1.00	1.00	1.00	1.00	1.00	1.00	8.32	582.12	4561.28	0.00	0.00	0.00	1.88	38.34	464.00

**Overall Maximum Deflections**

Load Combination	Span	Max. "-" Defl	Location in Span	Load Combination	Max. "+" Defl	Location in Span
+D+0.750L+0.750S+0.5250E+H	1	0.5108	7.555		0.0000	0.000

**Vertical Reactions**

Load Combination	Support notation : Far left is #'		Values in KIPS	
	Support 1	Support 2		
Overall MAXimum	8.029	8.029		
Overall MINimum	3.375	3.375		
+D+H	3.698	3.698		
+D+L+H	6.098	6.098		
+D+Lr+H	3.698	3.698		
+D+S+H	7.073	7.073		
+D+0.750Lr+0.750L+H	5.498	5.498		
+D+0.750L+0.750S+H	8.029	8.029		
+D+0.60W+H	3.698	3.698		
+D+0.750Lr+0.750L+0.450W+H	5.498	5.498		
+D+0.750L+0.750S+0.450W+H	8.029	8.029		
+0.60D+0.60W+0.60H	2.219	2.219		
+D+0.70E+0.60H	3.698	3.698		
+D+0.750L+0.750S+0.5250E+H	8.029	8.029		
+0.60D+0.70E+H	2.219	2.219		
D Only	3.698	3.698		
Lr Only				
L Only	2.400	2.400		
S Only	3.375	3.375		
W Only				
E Only				
H Only				

## Wood Beam

Lic. #: KW-06009431

### DESCRIPTIO BM#5

### CODE REFERENCES

Calculations per NDS 2015, IBC 2015, CBC 2016, ASCE 7-10  
Load Combination Set : ASCE 7-16

### Material Properties

Analysis Method	Allowable Stress Design	Fb +	2,900.0 psi	E : Modulus of Elasticity	
Load Combination	ASCE 7-16	Fb -	2,900.0 psi	Ebend- xx	2,000.0ksi
Wood Species	Trus Joist	Fc - Prll	2,900.0 psi	Eminbend - x	1,016.54ksi
Wood Grade	Parallam PSL 2.0E	Fc - Perp	625.0 psi		
		Fv	290.0 psi		
		Ft	2,025.0 psi	Density	45.070pcf
Beam Bracing	Beam is Fully Braced against lateral-torsional buckling				

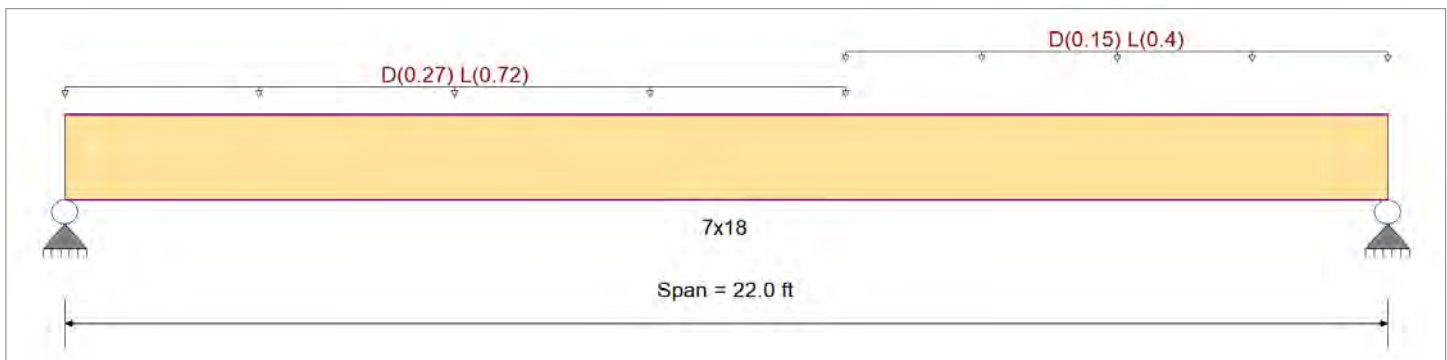

### Applied Loads

Service loads entered. Load Factors will be applied for calculations.

Beam self weight calculated and added to loads  
Load for Span Number 1

Uniform Load : D = 0.0150, L = 0.040 ksf, Extent = 0.0 --> 13.0 ft, Tributary Width = 18.0 ft, (FLOOR)

Uniform Load : D = 0.0150, L = 0.040 ksf, Extent = 13.0 --> 22.0 ft, Tributary Width = 10.0 ft, (FLOOR)

### DESIGN SUMMARY

**Design OK**

Maximum Bending Stress Ratio	=	<b>0.615</b>	1	Maximum Shear Stress Ratio	=	<b>0.371</b>	: 1
Section used for this span		<b>7x18</b>		Section used for this span		<b>7x18</b>	
	=	1,704.43psi			=	107.45 psi	
	=	2,772.37psi			=	290.00 psi	
Load Combination		<b>+D+L+H</b>		Load Combination		<b>+D+L+H</b>	
Location of maximum on span	=	10.197ft		Location of maximum on span	=	0.000ft	
Span # where maximum occurs	=	Span # 1		Span # where maximum occurs	=	Span # 1	
<b>Maximum Deflection</b>							
Max Downward Transient Deflection		0.472 in	Ratio =	<b>558</b>	>=	360	
Max Upward Transient Deflection		0.000 in	Ratio =	<b>0</b>	<	360	
Max Downward Total Deflection		0.680 in	Ratio =	<b>388</b>	>=	240	
Max Upward Total Deflection		0.000 in	Ratio =	<b>0</b>	<	240	

### Maximum Forces & Stresses for Load Combinations

Load Combination	Segment Length	Span #	Max Stress Ratios								Moment Values			Shear Values								
			M	V	C <sub>d</sub>	C <sub>F/V</sub>	C <sub>i</sub>	C <sub>r</sub>	C <sub>m</sub>	C <sub>t</sub>	C <sub>L</sub>	M	fb	F'b	V	fv	F'v					
+D+H	Length = 22.0 ft	1	0.208	0.125	0.90	0.956	1.00	1.00	1.00	1.00	1.00	1.00	1.00	16.37	519.67	2495.14	0.00	0.00	0.00	2.74	32.57	261.00
+D+L+H	Length = 22.0 ft	1	0.615	0.371	1.00	0.956	1.00	1.00	1.00	1.00	1.00	1.00	1.00	53.69	1,704.43	2772.37	0.00	0.00	0.00	9.03	107.45	290.00
+D+Lr+H	Length = 22.0 ft	1	0.150	0.090	1.25	0.956	1.00	1.00	1.00	1.00	1.00	1.00	1.00	16.37	519.67	3465.47	0.00	0.00	0.00	2.74	32.57	362.50
+D+S+H	Length = 22.0 ft	1	0.163	0.098	1.15	0.956	1.00	1.00	1.00	1.00	1.00	1.00	1.00	16.37	519.67	3188.23	0.00	0.00	0.00	2.74	32.57	333.50
+D+0.750Lr+0.750L+H	Length = 22.0 ft	1	0.406	0.245	1.25	0.956	1.00	1.00	1.00	1.00	1.00	1.00	1.00	44.36	1,408.23	3465.47	0.00	0.00	0.00	7.45	88.73	362.50
+D+0.750L+0.750S+H					0.956	1.00	1.00	1.00	1.00	1.00	1.00	1.00	1.00			0.00	0.00	0.00	0.00	0.00	0.00	0.00



**Wood Beam**

Lic. # : KW-06009431

**DESCRIPTIO BM#5**

Load Combination	Segment Length	Span #	Max Stress Ratios									Moment Values			Shear Values		
			M	V	C <sub>d</sub>	C <sub>F/V</sub>	C <sub>i</sub>	C <sub>r</sub>	C <sub>m</sub>	C <sub>t</sub>	C <sub>L</sub>	M	fb	F'b	V	fv	F'v
Length = 22.0 ft	1	0.442	0.266	1.15	0.956	1.00	1.00	1.00	1.00	1.00	44.36	1,408.23	3188.23	7.45	88.73	333.50	
+D+0.60W+H					0.956	1.00	1.00	1.00	1.00	1.00			0.00	0.00	0.00	0.00	
Length = 22.0 ft	1	0.117	0.070	1.60	0.956	1.00	1.00	1.00	1.00	1.00	16.37	519.67	4435.80	2.74	32.57	464.00	
+D+0.750Lr+0.750L+0.450W-					0.956	1.00	1.00	1.00	1.00	1.00			0.00	0.00	0.00	0.00	
Length = 22.0 ft	1	0.317	0.191	1.60	0.956	1.00	1.00	1.00	1.00	1.00	44.36	1,408.23	4435.80	7.45	88.73	464.00	
+D+0.750L+0.750S+0.450W+					0.956	1.00	1.00	1.00	1.00	1.00			0.00	0.00	0.00	0.00	
Length = 22.0 ft	1	0.317	0.191	1.60	0.956	1.00	1.00	1.00	1.00	1.00	44.36	1,408.23	4435.80	7.45	88.73	464.00	
+0.60D+0.60W+0.60H					0.956	1.00	1.00	1.00	1.00	1.00			0.00	0.00	0.00	0.00	
Length = 22.0 ft	1	0.070	0.042	1.60	0.956	1.00	1.00	1.00	1.00	1.00	9.82	311.80	4435.80	1.64	19.54	464.00	
+D+0.70E+0.60H					0.956	1.00	1.00	1.00	1.00	1.00			0.00	0.00	0.00	0.00	
Length = 22.0 ft	1	0.117	0.070	1.60	0.956	1.00	1.00	1.00	1.00	1.00	16.37	519.67	4435.80	2.74	32.57	464.00	
+D+0.750L+0.750S+0.5250E-					0.956	1.00	1.00	1.00	1.00	1.00			0.00	0.00	0.00	0.00	
Length = 22.0 ft	1	0.317	0.191	1.60	0.956	1.00	1.00	1.00	1.00	1.00	44.36	1,408.23	4435.80	7.45	88.73	464.00	
+0.60D+0.70E+H					0.956	1.00	1.00	1.00	1.00	1.00			0.00	0.00	0.00	0.00	
Length = 22.0 ft	1	0.070	0.042	1.60	0.956	1.00	1.00	1.00	1.00	1.00	9.82	311.80	4435.80	1.64	19.54	464.00	

**Overall Maximum Deflections**

Load Combination	Span	Max. "-" Defl	Location in Span	Load Combination	Max. "+" Defl	Location in Span
+D+L+H	1	0.6802	10.839		0.0000	0.000

**Vertical Reactions**

Load Combination	Support notation : Far left is #'		Values in KIPS	
	Support 1	Support 2		
Overall MAXimum	10.514	8.174		
Overall MINimum	7.331	5.629		
+D+H	3.183	2.545		
+D+L+H	10.514	8.174		
+D+Lr+H	3.183	2.545		
+D+S+H	3.183	2.545		
+D+0.750Lr+0.750L+H	8.681	6.767		
+D+0.750L+0.750S+H	8.681	6.767		
+D+0.60W+H	3.183	2.545		
+D+0.750Lr+0.750L+0.450W+H	8.681	6.767		
+D+0.750L+0.750S+0.450W+H	8.681	6.767		
+0.60D+0.60W+0.60H	1.910	1.527		
+D+0.70E+0.60H	3.183	2.545		
+D+0.750L+0.750S+0.5250E+H	8.681	6.767		
+0.60D+0.70E+H	1.910	1.527		
D Only	3.183	2.545		
Lr Only				
L Only	7.331	5.629		
S Only				
W Only				
E Only				
H Only				

## Wood Beam

Lic. # : KW-06009431

### DESCRIPTIO BM#6

### CODE REFERENCES

Calculations per NDS 2015, IBC 2015, CBC 2016, ASCE 7-10  
Load Combination Set : ASCE 7-16

### Material Properties

Analysis Method	Allowable Stress Design	Fb +	2,900.0 psi	E : Modulus of Elasti	
Load Combination	ASCE 7-16	Fb -	2,900.0 psi	Ebend- xx	2,000.0ksi
Wood Species	Trus Joist	Fc - Prll	2,900.0 psi	Eminbend - x	1,016.54ksi
Wood Grade	Parallam PSL 2.0E	Fc - Perp	625.0 psi		
		Fv	290.0 psi		
		Ft	2,025.0 psi	Density	45.070pcf
Beam Bracing	Beam is Fully Braced against lateral-torsional buckling				

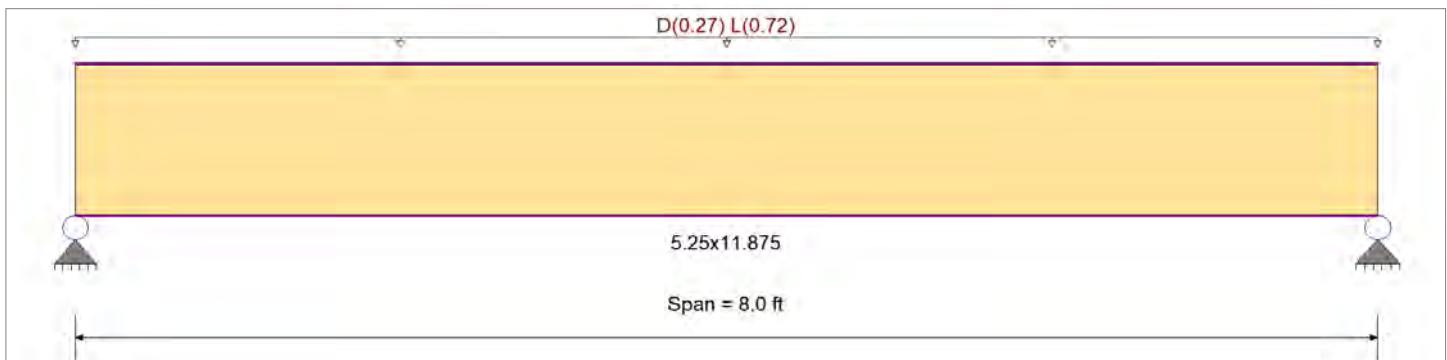

### Applied Loads

Service loads entered. Load Factors will be applied for calculations.

Beam self weight calculated and added to loads

Uniform Load : D = 0.0150, L = 0.040 ksf, Tributary Width = 18.0 ft, (FLOOR)

### DESIGN SUMMARY

**Design OK**

Maximum Bending Stress Ratio	=	<b>0.271</b> : 1	Maximum Shear Stress Ratio	=	<b>0.254</b> : 1
Section used for this span	=	<b>5.25x11.875</b>	Section used for this span	=	<b>5.25x11.875</b>
	=	785.43psi		=	73.75 psi
	=	2,900.00psi		=	290.00 psi
Load Combination	=	+D+L+H	Load Combination	=	+D+L+H
Location of maximum on span	=	4.000ft	Location of maximum on span	=	7.036 ft
Span # where maximum occurs	=	Span # 1	Span # where maximum occurs	=	Span # 1
<b>Maximum Deflection</b>					
Max Downward Transient Deflection		0.046 in	Ratio =	2107	>=360
Max Upward Transient Deflection		0.000 in	Ratio =	0	<360
Max Downward Total Deflection		0.064 in	Ratio =	1503	>=240
Max Upward Total Deflection		0.000 in	Ratio =	0	<240

### Maximum Forces & Stresses for Load Combinations

Load Combination	Segment Length	Span #	Max Stress Ratios									Moment Values			Shear Values							
			M	V	C <sub>d</sub>	C <sub>F/V</sub>	C <sub>i</sub>	C <sub>r</sub>	C <sub>m</sub>	C <sub>t</sub>	C <sub>L</sub>	M	fb	F'b	V	fv	F'v					
+D+H	Length = 8.0 ft	1	0.086	0.081	0.90	1.000	1.00	1.00	1.00	1.00	1.00	1.00	1.00	1.00	1.00	1.00	0.00	0.00	0.00	0.00	0.00	0.00
+D+L+H	Length = 8.0 ft	1	0.271	0.254	1.00	1.000	1.00	1.00	1.00	1.00	1.00	1.00	1.00	1.00	1.00	1.00	0.00	0.00	0.00	0.00	0.00	0.00
+D+Lr+H	Length = 8.0 ft	1	0.062	0.058	1.25	1.000	1.00	1.00	1.00	1.00	1.00	1.00	1.00	1.00	1.00	1.00	0.00	0.00	0.00	0.00	0.00	0.00
+D+S+H	Length = 8.0 ft	1	0.068	0.063	1.15	1.000	1.00	1.00	1.00	1.00	1.00	1.00	1.00	1.00	1.00	1.00	0.00	0.00	0.00	0.00	0.00	0.00
+D+0.750Lr+0.750L+H	Length = 8.0 ft	1	0.178	0.167	1.25	1.000	1.00	1.00	1.00	1.00	1.00	1.00	1.00	1.00	1.00	1.00	0.00	0.00	0.00	0.00	0.00	0.00
+D+0.750L+0.750S+H	Length = 8.0 ft	1	0.194	0.182	1.15	1.000	1.00	1.00	1.00	1.00	1.00	1.00	1.00	1.00	1.00	1.00	0.00	0.00	0.00	0.00	0.00	0.00
+D+0.60W+H						1.000	1.00	1.00	1.00	1.00	1.00	1.00	1.00	1.00	1.00	1.00	0.00	0.00	0.00	0.00	0.00	0.00

**Wood Beam**

Lic. # : KW-06009431

**DESCRIPTIO BM#6**

Load Combination	Segment Length	Span #	Max Stress Ratios									Moment Values			Shear Values		
			M	V	C <sub>d</sub>	C <sub>F/V</sub>	C <sub>i</sub>	C <sub>r</sub>	C <sub>m</sub>	C <sub>t</sub>	C <sub>L</sub>	M	fb	F'b	V	fv	F'v
Length = 8.0 ft	1	0.049	0.046	1.60	1.000	1.00	1.00	1.00	1.00	1.00	1.00	2.32	225.25	4640.00	0.88	21.15	464.00
+D+0.750Lr+0.750L+0.450W-					1.000	1.00	1.00	1.00	1.00	1.00	1.00			0.00	0.00	0.00	0.00
Length = 8.0 ft	1	0.139	0.131	1.60	1.000	1.00	1.00	1.00	1.00	1.00	1.00	6.64	645.39	4640.00	2.52	60.60	464.00
+D+0.750L+0.750S+0.450W+					1.000	1.00	1.00	1.00	1.00	1.00	1.00			0.00	0.00	0.00	0.00
Length = 8.0 ft	1	0.139	0.131	1.60	1.000	1.00	1.00	1.00	1.00	1.00	1.00	6.64	645.39	4640.00	2.52	60.60	464.00
+0.60D+0.60W+0.60H					1.000	1.00	1.00	1.00	1.00	1.00	1.00			0.00	0.00	0.00	0.00
Length = 8.0 ft	1	0.029	0.027	1.60	1.000	1.00	1.00	1.00	1.00	1.00	1.00	1.39	135.15	4640.00	0.53	12.69	464.00
+D+0.70E+0.60H					1.000	1.00	1.00	1.00	1.00	1.00	1.00			0.00	0.00	0.00	0.00
Length = 8.0 ft	1	0.049	0.046	1.60	1.000	1.00	1.00	1.00	1.00	1.00	1.00	2.32	225.25	4640.00	0.88	21.15	464.00
+D+0.750L+0.750S+0.5250E-					1.000	1.00	1.00	1.00	1.00	1.00	1.00			0.00	0.00	0.00	0.00
Length = 8.0 ft	1	0.139	0.131	1.60	1.000	1.00	1.00	1.00	1.00	1.00	1.00	6.64	645.39	4640.00	2.52	60.60	464.00
+0.60D+0.70E+H					1.000	1.00	1.00	1.00	1.00	1.00	1.00			0.00	0.00	0.00	0.00
Length = 8.0 ft	1	0.029	0.027	1.60	1.000	1.00	1.00	1.00	1.00	1.00	1.00	1.39	135.15	4640.00	0.53	12.69	464.00

**Overall Maximum Deflections**

Load Combination	Span	Max. "-" Defl	Location in Span	Load Combination	Max. "+" Defl	Location in Span
+D+L+H	1	0.0639	4.029		0.0000	0.000

**Vertical Reactions**

Support notation : Far left is #'

Values in KIPS

Load Combination	Support 1	Support 2
Overall MAXimum	4.038	4.038
Overall MINimum	2.880	2.880
+D+H	1.158	1.158
+D+L+H	4.038	4.038
+D+Lr+H	1.158	1.158
+D+S+H	1.158	1.158
+D+0.750Lr+0.750L+H	3.318	3.318
+D+0.750L+0.750S+H	3.318	3.318
+D+0.60W+H	1.158	1.158
+D+0.750Lr+0.750L+0.450W+H	3.318	3.318
+D+0.750L+0.750S+0.450W+H	3.318	3.318
+0.60D+0.60W+0.60H	0.695	0.695
+D+0.70E+0.60H	1.158	1.158
+D+0.750L+0.750S+0.5250E+H	3.318	3.318
+0.60D+0.70E+H	0.695	0.695
D Only	1.158	1.158
Lr Only		
L Only	2.880	2.880
S Only		
W Only		
E Only		
H Only		

**Wood Beam**

File = C:\Users\pasko\Desktop\test.ec6 .  
 Software copyright ENERCALC, INC. 1983-2019, Build:12.19.11.30 .  
 CK Engineering LLC

Lic. # : KW-06009431

**DESCRIPTIO BM#7**

**CODE REFERENCES**

Calculations per NDS 2015, IBC 2015, CBC 2016, ASCE 7-10  
 Load Combination Set : ASCE 7-16

**Material Properties**

Analysis Method	Allowable Stress Design	Fb +	2,900.0 psi	E : Modulus of Elasticity	
Load Combination	ASCE 7-16	Fb -	2,900.0 psi	Ebend- xx	2,000.0ksi
Wood Species	Trus Joist	Fc - Prll	2,900.0 psi	Eminbend - x	1,016.54ksi
Wood Grade	Parallam PSL 2.0E	Fc - Perp	625.0 psi		
		Fv	290.0 psi		
		Ft	2,025.0 psi	Density	45.070pcf
Beam Bracing	Beam is Fully Braced against lateral-torsional buckling				



**Applied Loads**

Service loads entered. Load Factors will be applied for calculations.

Beam self weight calculated and added to loads  
 Point Load : D = 3.180, L = 7.330 k @ 1.50 ft, (BM#5)  
 Point Load : D = 1.160, L = 2.880 k @ 3.50 ft, (BM#6)

**DESIGN SUMMARY**

**Design OK**

Maximum Bending Stress Ratio	=	<b>0.172</b>	1	Maximum Shear Stress Ratio	=	<b>0.370</b>	: 1
Section used for this span	=	<b>5.25x16.0</b>		Section used for this span	=	<b>5.25x16.0</b>	
	=	482.96psi			=	107.44 psi	
	=	2,808.86psi			=	290.00 psi	
Load Combination	=	<b>+D+L+H</b>		Load Combination	=	<b>+D+L+H</b>	
Location of maximum on span	=	1.507ft		Location of maximum on span	=	0.000ft	
Span # where maximum occurs	=	<b>Span # 1</b>		Span # where maximum occurs	=	<b>Span # 1</b>	
<b>Maximum Deflection</b>							
Max Downward Transient Deflection		0.003 in	Ratio =	13590	>=	360	
Max Upward Transient Deflection		0.000 in	Ratio =	0	<	360	
Max Downward Total Deflection		0.004 in	Ratio =	9425	>=	240	
Max Upward Total Deflection		0.000 in	Ratio =	0	<	240	

**Maximum Forces & Stresses for Load Combinations**

Load Combination	Segment Length	Span #	Max Stress Ratios								Moment Values			Shear Values						
			M	V	C <sub>d</sub>	C <sub>F/V</sub>	C <sub>i</sub>	C <sub>r</sub>	C <sub>m</sub>	C <sub>t</sub>	C <sub>L</sub>	M	fb	F'b	V	fv	F'v			
+D+H	Length = 3.50 ft	1	0.058	0.125	0.90	0.969	1.00	1.00	1.00	1.00	1.00	2.76	147.60	2527.97	0.00	0.00	0.00	1.83	32.65	261.00
+D+L+H	Length = 3.50 ft	1				0.969	1.00	1.00	1.00	1.00	1.00	9.02	482.96	2808.86	0.00	0.00	0.00	6.02	107.44	290.00
+D+Lr+H	Length = 3.50 ft	1				0.969	1.00	1.00	1.00	1.00	1.00	2.76	147.60	3511.07	0.00	0.00	0.00	1.83	32.65	362.50
+D+S+H	Length = 3.50 ft	1				0.969	1.00	1.00	1.00	1.00	1.00	2.76	147.60	3230.19	0.00	0.00	0.00	1.83	32.65	333.50
+D+0.750Lr+0.750L+H	Length = 3.50 ft	1				0.969	1.00	1.00	1.00	1.00	1.00	7.45	399.12	3511.07	0.00	0.00	0.00	4.97	88.74	362.50
+D+0.750L+0.750S+H	Length = 3.50 ft	1				0.969	1.00	1.00	1.00	1.00	1.00	7.45	399.12	3230.19	0.00	0.00	0.00	4.97	88.74	333.50



**Wood Beam**

Lic. # : KW-06009431

**DESCRIPTIO BM#7**

Load Combination	Segment Length	Span #	Max Stress Ratios							Moment Values			Shear Values										
			M	V	C <sub>d</sub>	C <sub>F/V</sub>	C <sub>i</sub>	C <sub>r</sub>	C <sub>m</sub>	C <sub>t</sub>	C <sub>L</sub>	M	fb	F'b	V	fv	F'v						
+D+0.60W+H	Length = 3.50 ft	1	0.033	0.070	1.60	0.969	1.00	1.00	1.00	1.00	1.00	1.00	1.00	1.00	2.76	147.60	4494.17	0.00	0.00	0.00	1.83	32.65	464.00
+D+0.750Lr+0.750L+0.450W-	Length = 3.50 ft	1	0.089	0.191	1.60	0.969	1.00	1.00	1.00	1.00	1.00	1.00	1.00	1.00	7.45	399.12	4494.17	0.00	0.00	0.00	4.97	88.74	464.00
+D+0.750L+0.750S+0.450W+	Length = 3.50 ft	1	0.089	0.191	1.60	0.969	1.00	1.00	1.00	1.00	1.00	1.00	1.00	1.00	7.45	399.12	4494.17	0.00	0.00	0.00	4.97	88.74	464.00
+0.60D+0.60W+0.60H	Length = 3.50 ft	1	0.020	0.042	1.60	0.969	1.00	1.00	1.00	1.00	1.00	1.00	1.00	1.00	1.65	88.56	4494.17	0.00	0.00	0.00	1.10	19.59	464.00
+D+0.70E+0.60H	Length = 3.50 ft	1	0.033	0.070	1.60	0.969	1.00	1.00	1.00	1.00	1.00	1.00	1.00	1.00	2.76	147.60	4494.17	0.00	0.00	0.00	1.83	32.65	464.00
+D+0.750L+0.750S+0.5250E-	Length = 3.50 ft	1	0.089	0.191	1.60	0.969	1.00	1.00	1.00	1.00	1.00	1.00	1.00	1.00	7.45	399.12	4494.17	0.00	0.00	0.00	4.97	88.74	464.00
+0.60D+0.70E+H	Length = 3.50 ft	1	0.020	0.042	1.60	0.969	1.00	1.00	1.00	1.00	1.00	1.00	1.00	1.00	1.65	88.56	4494.17	0.00	0.00	0.00	1.10	19.59	464.00

**Overall Maximum Deflections**

Load Combination	Span	Max. "-" Defl	Location in Span	Load Combination	Max. "+" Defl	Location in Span
+D+L+H	1	0.0045	1.686		0.0000	0.000

**Vertical Reactions**

Load Combination	Support notation : Far left is #'		Values in KIPS	
	Support 1	Support 2		
Overall MAXimum	6.052	8.590		
Overall MINimum	4.189	6.021		
+D+H	1.863	2.569		
+D+L+H	6.052	8.590		
+D+Lr+H	1.863	2.569		
+D+S+H	1.863	2.569		
+D+0.750Lr+0.750L+H	5.005	7.085		
+D+0.750L+0.750S+H	5.005	7.085		
+D+0.60W+H	1.863	2.569		
+D+0.750Lr+0.750L+0.450W+H	5.005	7.085		
+D+0.750L+0.750S+0.450W+H	5.005	7.085		
+0.60D+0.60W+0.60H	1.118	1.541		
+D+0.70E+0.60H	1.863	2.569		
+D+0.750L+0.750S+0.5250E+H	5.005	7.085		
+0.60D+0.70E+H	1.118	1.541		
D Only	1.863	2.569		
Lr Only				
L Only	4.189	6.021		
S Only				
W Only				
E Only				
H Only				

## Wood Beam

Lic. # : KW-06009431

### DESCRIPTIO BM#8

### CODE REFERENCES

Calculations per NDS 2015, IBC 2015, CBC 2016, ASCE 7-10  
Load Combination Set : ASCE 7-16

### Material Properties

Analysis Method	Allowable Stress Design	Fb +	2400 psi	E : Modulus of Elasticity	
Load Combination	ASCE 7-16	Fb -	1850 psi	Ebend- xx	1800ksi
Wood Species	DF/DF	Fc - Prll	1650 psi	Eminbend - x	950ksi
Wood Grade	24F - V4	Fc - Perp	650 psi	Ebend- yy	1600ksi
		Fv	265 psi	Eminbend - y	850ksi
		Ft	1100 psi	Density	31.21 pcf
Beam Bracing	Beam is Fully Braced against lateral-torsional buckling				

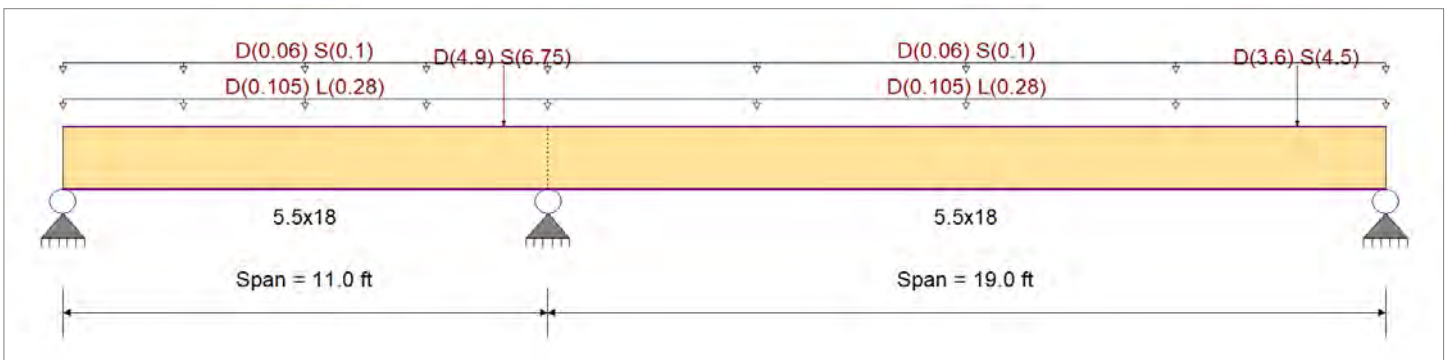

### Applied Loads

Service loads entered. Load Factors will be applied for calculations.

Beam self weight calculated and added to loads  
Load for Span Number 1

- Uniform Load : D = 0.0150, L = 0.040 ksf, Tributary Width = 7.0 ft, (FLOOR)
- Uniform Load : D = 0.0150, S = 0.0250 ksf, Tributary Width = 4.0 ft, (LOWER ROOF)
- Point Load : D = 4.90, S = 6.750 k @ 10.0 ft, (G.T.#1)

Load for Span Number 2

- Uniform Load : D = 0.0150, L = 0.040 ksf, Tributary Width = 7.0 ft, (FLOOR)
- Uniform Load : D = 0.0150, S = 0.0250 ksf, Tributary Width = 4.0 ft, (LOWER ROOF)
- Point Load : D = 3.60, S = 4.50 k @ 17.0 ft, (G.T.#3)

### DESIGN SUMMARY

**Design OK**

Maximum Bending Stress Ratio	=	<b>0.466</b>	1	Maximum Shear Stress Ratio	=	<b>0.436</b>	: 1
Section used for this span	=	<b>5.5x18</b>		Section used for this span	=	<b>5.5x18</b>	
	=	954.62psi			=	132.96 psi	
	=	2,048.99psi			=	304.75 psi	
Load Combination	+D+0.750L+0.750S+H			Load Combination	+D+0.750L+0.750S+H		
Location of maximum on span	=	0.000ft		Location of maximum on span	=	17.514 ft	
Span # where maximum occurs	=	Span # 2		Span # where maximum occurs	=	Span # 2	
<b>Maximum Deflection</b>							
Max Downward Transient Deflection		0.095 in	Ratio =	2403	>=	360	
Max Upward Transient Deflection		-0.009 in	Ratio =	14413	>=	360	
Max Downward Total Deflection		0.217 in	Ratio =	1052	>=	240	
Max Upward Total Deflection		-0.013 in	Ratio =	10354	>=	240	

### Maximum Forces & Stresses for Load Combinations

Load Combination	Segment Length	Span #	Max Stress Ratios									Moment Values			Shear Values						
			M	V	C <sub>d</sub>	C <sub>F/V</sub>	C <sub>i</sub>	C <sub>r</sub>	C <sub>m</sub>	C <sub>t</sub>	C <sub>L</sub>	M	fb	F'b	V	fv	F'v				
+D+H	Length = 11.0 ft	1	0.247	0.153	0.90	1.000	1.00	1.00	1.00	1.00	1.00	1.00	1.00	1.00	10.18	411.18	1665.00	0.00	0.00	0.00	0.00
	Length = 19.0 ft	2	0.256	0.266	0.90	0.963	1.00	1.00	1.00	1.00	1.00	1.00	1.00	1.00	10.18	411.18	1603.56	0.00	4.18	63.33	238.50
+D+L+H	Length = 11.0 ft	1	0.431	0.295	1.00	1.000	1.00	1.00	1.00	1.00	1.00	1.00	1.00	1.00	19.73	797.24	1850.00	5.16	0.00	0.00	0.00

**Wood Beam**

Lic. # : KW-06009431

**DESCRIPTIO BM#8**

Load Combination	Segment Length	Span #	Max Stress Ratios								Moment Values			Shear Values			
			M	V	C <sub>d</sub>	C <sub>F/V</sub>	C <sub>i</sub>	C <sub>r</sub>	C <sub>m</sub>	C <sub>t</sub>	C <sub>L</sub>	M	fb	F'b	V	fv	F'v
+D+Lr+H	Length = 19.0 ft	2	0.447	0.339	1.00	0.963	1.00	1.00	1.00	1.00	1.00	19.73	797.24	1781.73	5.92	89.71	265.00
						0.963	1.00	1.00	1.00	1.00	1.00			0.00	0.00	0.00	0.00
+D+S+H	Length = 11.0 ft	1	0.178	0.110	1.25	1.000	1.00	1.00	1.00	1.00	1.00	10.18	411.18	2312.50	2.41	36.50	331.25
	Length = 19.0 ft	2	0.185	0.191	1.25	0.963	1.00	1.00	1.00	1.00	1.00	10.18	411.18	2227.16	4.18	63.33	331.25
+D+0.750Lr+0.750L+H						0.963	1.00	1.00	1.00	1.00				0.00	0.00	0.00	
	Length = 11.0 ft	1	0.352	0.205	1.15	1.000	1.00	1.00	1.00	1.00	1.00	18.56	749.71	2127.50	4.12	62.50	304.75
+D+0.750L+0.750S+H	Length = 19.0 ft	2	0.366	0.426	1.15	0.963	1.00	1.00	1.00	1.00	1.00	18.56	749.71	2048.99	8.57	129.79	304.75
						0.963	1.00	1.00	1.00	1.00				0.00	0.00	0.00	
+D+0.60W+H	Length = 11.0 ft	1	0.303	0.204	1.25	1.000	1.00	1.00	1.00	1.00	1.00	17.34	700.72	2312.50	4.47	67.71	331.25
	Length = 19.0 ft	2	0.315	0.251	1.25	0.963	1.00	1.00	1.00	1.00	1.00	17.34	700.72	2227.16	5.49	83.11	331.25
+D+0.750L+0.750S+0.450W+						0.963	1.00	1.00	1.00	1.00				0.00	0.00	0.00	
	Length = 11.0 ft	1	0.449	0.286	1.15	1.000	1.00	1.00	1.00	1.00	1.00	23.63	954.62	2127.50	5.76	87.21	304.75
+D+0.60D+0.60W+0.60H	Length = 19.0 ft	2	0.466	0.436	1.15	0.963	1.00	1.00	1.00	1.00	1.00	23.63	954.62	2048.99	8.78	132.96	304.75
						0.963	1.00	1.00	1.00	1.00				0.00	0.00	0.00	
+D+0.750Lr+0.750L+0.450W-	Length = 11.0 ft	1	0.139	0.086	1.60	1.000	1.00	1.00	1.00	1.00	1.00	10.18	411.18	2960.00	2.41	36.50	424.00
	Length = 19.0 ft	2	0.144	0.149	1.60	0.963	1.00	1.00	1.00	1.00	1.00	10.18	411.18	2850.77	4.18	63.33	424.00
+D+0.750L+0.750S+0.450W+						0.963	1.00	1.00	1.00	1.00				0.00	0.00	0.00	
	Length = 11.0 ft	1	0.237	0.160	1.60	1.000	1.00	1.00	1.00	1.00	1.00	17.34	700.72	2960.00	4.47	67.71	424.00
+D+0.60D+0.60W+0.60H	Length = 19.0 ft	2	0.246	0.196	1.60	0.963	1.00	1.00	1.00	1.00	1.00	17.34	700.72	2850.77	5.49	83.11	424.00
						0.963	1.00	1.00	1.00	1.00				0.00	0.00	0.00	
+D+0.70E+0.60H	Length = 11.0 ft	1	0.323	0.206	1.60	1.000	1.00	1.00	1.00	1.00	1.00	23.63	954.62	2960.00	5.76	87.21	424.00
	Length = 19.0 ft	2	0.335	0.314	1.60	0.963	1.00	1.00	1.00	1.00	1.00	23.63	954.62	2850.77	8.78	132.96	424.00
+D+0.750L+0.750S+0.5250E-						0.963	1.00	1.00	1.00	1.00				0.00	0.00	0.00	
	Length = 11.0 ft	1	0.083	0.052	1.60	1.000	1.00	1.00	1.00	1.00	1.00	6.11	246.71	2960.00	1.45	21.90	424.00
+D+0.60D+0.70E+H	Length = 19.0 ft	2	0.087	0.090	1.60	0.963	1.00	1.00	1.00	1.00	1.00	6.11	246.71	2850.77	2.51	38.00	424.00
						0.963	1.00	1.00	1.00	1.00				0.00	0.00	0.00	
+D+0.750L+0.750S+0.5250E+H	Length = 11.0 ft	1	0.139	0.086	1.60	1.000	1.00	1.00	1.00	1.00	1.00	10.18	411.18	2960.00	2.41	36.50	424.00
	Length = 19.0 ft	2	0.144	0.149	1.60	0.963	1.00	1.00	1.00	1.00	1.00	10.18	411.18	2850.77	4.18	63.33	424.00
+D+0.60D+0.70E+H						0.963	1.00	1.00	1.00	1.00				0.00	0.00	0.00	
	Length = 11.0 ft	1	0.083	0.052	1.60	1.000	1.00	1.00	1.00	1.00	1.00	6.11	246.71	2960.00	1.45	21.90	424.00
+D+0.60D+0.70E+H	Length = 19.0 ft	2	0.087	0.090	1.60	0.963	1.00	1.00	1.00	1.00	1.00	6.11	246.71	2850.77	2.51	38.00	424.00
						0.963	1.00	1.00	1.00	1.00				0.00	0.00	0.00	

**Overall Maximum Deflections**

Load Combination	Span	Max. "-" Defl	Location in Span	Load Combination	Max. "+" Defl	Location in Span
+D+S+H	1	0.0019	2.212	+D+L+H	-0.0127	8.112
+D+0.750L+0.750S+0.5250E+H	2	0.2166	11.145		0.0000	8.112

**Vertical Reactions**

Load Combination	Support notation : Far left is #'			Values in KIPS
	Support 1	Support 2	Support 3	
Overall MAXimum	1.351	20.254	9.476	
Overall MINimum	0.402	9.313	4.535	
+D+H	0.546	9.091	4.457	
+D+L+H	1.217	14.663	6.614	
+D+Lr+H	0.546	9.091	4.457	
+D+S+H	0.948	18.404	8.992	
+D+0.750Lr+0.750L+H	1.049	13.270	6.075	
+D+0.750L+0.750S+H	1.351	20.254	9.476	
+D+0.60W+H	0.546	9.091	4.457	
+D+0.750Lr+0.750L+0.450W+H	1.049	13.270	6.075	
+D+0.750L+0.750S+0.450W+H	1.351	20.254	9.476	
+0.60D+0.60W+0.60H	0.327	5.455	2.674	
+D+0.70E+0.60H	0.546	9.091	4.457	
+D+0.750L+0.750S+0.5250E+H	1.351	20.254	9.476	
+0.60D+0.70E+H	0.327	5.455	2.674	
D Only	0.546	9.091	4.457	
Lr Only				
L Only	0.671	5.572	2.157	

Feaster Residence  
7544 31st Ave NW  
Seattle, WA 98117  
Permit # 6736413 - CM

Project Title:  
Engineer:  
Project ID:  
Project Descr:

Printed: 12 JAN 2020, 10:14AM

## Wood Beam

File = C:\Users\pasko\Desktop\test.ec6 .  
Software copyright ENERCALC, INC. 1983-2019, Build:12.19.11.30 .  
CK Engineering LLC

Lic. # : KW-06009431

### DESCRIPTIO BM#8

#### Vertical Reactions

Support notation : Far left is #'

Values in KIPS

Load Combination	Support 1	Support 2	Support 3
S Only	0.402	9.313	4.535
W Only			
E Only			
H Only			

**Wood Beam**

Lic. # : KW-06009431

**DESCRIPTIO BM#9**

**CODE REFERENCES**

Calculations per NDS 2015, IBC 2015, CBC 2016, ASCE 7-10  
 Load Combination Set : ASCE 7-16

**Material Properties**

Analysis Method	Allowable Stress Design	Fb +	2,900.0 psi	E : Modulus of Elasti	
Load Combination	ASCE 7-16	Fb -	2,900.0 psi	Ebend- xx	2,000.0ksi
Wood Species	Trus Joist	Fc - Prll	2,900.0 psi	Eminbend - x	1,016.54ksi
Wood Grade	Parallam PSL 2.0E	Fc - Perp	625.0 psi		
		Fv	290.0 psi		
		Ft	2,025.0 psi	Density	45.070pcf
Beam Bracing	Beam is Fully Braced against lateral-torsional buckling				

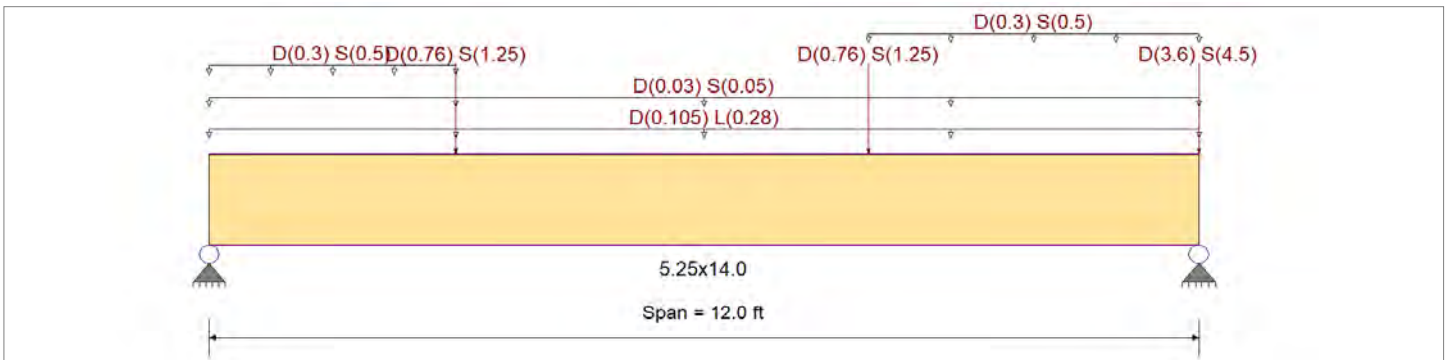

**Applied Loads**

Service loads entered. Load Factors will be applied for calculations.

Beam self weight calculated and added to loads

- Uniform Load : D = 0.0150, L = 0.040 ksf, Tributary Width = 7.0 ft, (FLOOR)
- Uniform Load : D = 0.0150, S = 0.0250 ksf, Tributary Width = 2.0 ft, (LOWER ROOF)
- Point Load : D = 3.60, S = 4.50 k @ 12.0 ft, (G.T.#3)
- Uniform Load : D = 0.0150, S = 0.0250 ksf, Extent = 0.0 -->> 3.0 ft, Tributary Width = 20.0 ft, (UPPER ROOF)
- Uniform Load : D = 0.0150, S = 0.0250 ksf, Extent = 8.0 -->> 12.0 ft, Tributary Width = 20.0 ft, (UPPER ROOF)
- Point Load : D = 0.760, S = 1.250 k @ 3.0 ft, (HDR#2)
- Point Load : D = 0.760, S = 1.250 k @ 8.0 ft, (HDR#2)

**DESIGN SUMMARY**

**Design OK**

Maximum Bending Stress Ratio	=	<b>0.376</b> : 1	Maximum Shear Stress Ratio	=	<b>0.322</b> : 1
Section used for this span	=	<b>5.25x14.0</b>	Section used for this span	=	<b>5.25x14.0</b>
	=	1,231.50psi		=	107.42 psi
	=	3,278.42psi		=	333.50 psi
Load Combination	+D+0.750L+0.750S+H		Load Combination	+D+0.750L+0.750S+H	
Location of maximum on span	=	6.832ft	Location of maximum on span	=	0.000ft
Span # where maximum occurs	=	Span # 1	Span # where maximum occurs	=	Span # 1

**Maximum Deflection**

Max Downward Transient Deflection	0.098 in	Ratio =	<b>1467</b> >=360
Max Upward Transient Deflection	0.000 in	Ratio =	<b>0</b> <360
Max Downward Total Deflection	0.199 in	Ratio =	<b>723</b> >=240
Max Upward Total Deflection	0.000 in	Ratio =	<b>0</b> <240

**Maximum Forces & Stresses for Load Combinations**

Load Combination	Segment Length	Span #	Max Stress Ratios									Moment Values			Shear Values			
			M	V	C <sub>d</sub>	C <sub>F/V</sub>	C <sub>i</sub>	C <sub>r</sub>	C <sub>m</sub>	C <sub>t</sub>	C <sub>L</sub>	M	fb	F'b	V	fv	F'v	
+D+H	Length = 12.0 ft	1	0.203	0.175	0.90	0.983	1.00	1.00	1.00	1.00	1.00	7.45	521.36	2565.72	0.00	0.00	0.00	0.00
+D+L+H	Length = 12.0 ft	1	0.305	0.253	1.00	0.983	1.00	1.00	1.00	1.00	1.00	12.45	870.79	2850.80	0.00	0.00	0.00	0.00
+D+Lr+H	Length = 12.0 ft	1	0.146	0.126	1.25	0.983	1.00	1.00	1.00	1.00	1.00	7.45	521.36	3563.50	0.00	0.00	0.00	0.00



**Wood Beam**

Lic. # : KW-06009431

**DESCRIPTIO BM#9**

Load Combination	Segment Length	Span #	Max Stress Ratios								Moment Values			Shear Values					
			M	V	C <sub>d</sub>	C <sub>F/V</sub>	C <sub>i</sub>	C <sub>r</sub>	C <sub>m</sub>	C <sub>t</sub>	C <sub>L</sub>	M	fb	F'b	V	fv	Fv		
+D+S+H	Length = 12.0 ft	1	0.345	0.301	1.15	0.983	1.00	1.00	1.00	1.00	1.00	1.00	1.00	16.17	1,131.10	3278.42	4.91	100.23	333.50
+D+0.750Lr+0.750L+H	Length = 12.0 ft	1	0.220	0.183	1.25	0.983	1.00	1.00	1.00	1.00	1.00	1.00	1.00	11.19	782.97	3563.50	3.26	66.49	362.50
+D+0.750L+0.750S+H	Length = 12.0 ft	1	0.376	0.322	1.15	0.983	1.00	1.00	1.00	1.00	1.00	1.00	1.00	17.60	1,231.50	3278.42	5.26	107.42	333.50
+D+0.60W+H	Length = 12.0 ft	1	0.114	0.098	1.60	0.983	1.00	1.00	1.00	1.00	1.00	1.00	1.00	7.45	521.36	4561.28	2.24	45.66	464.00
+D+0.750Lr+0.750L+0.450W-	Length = 12.0 ft	1	0.172	0.143	1.60	0.983	1.00	1.00	1.00	1.00	1.00	1.00	1.00	11.19	782.97	4561.28	3.26	66.49	464.00
+D+0.750L+0.750S+0.450W+	Length = 12.0 ft	1	0.270	0.232	1.60	0.983	1.00	1.00	1.00	1.00	1.00	1.00	1.00	17.60	1,231.50	4561.28	5.26	107.42	464.00
+0.60D+0.60W+0.60H	Length = 12.0 ft	1	0.069	0.059	1.60	0.983	1.00	1.00	1.00	1.00	1.00	1.00	1.00	4.47	312.81	4561.28	1.34	27.40	464.00
+D+0.70E+0.60H	Length = 12.0 ft	1	0.114	0.098	1.60	0.983	1.00	1.00	1.00	1.00	1.00	1.00	1.00	7.45	521.36	4561.28	2.24	45.66	464.00
+D+0.750L+0.750S+0.5250E-	Length = 12.0 ft	1	0.270	0.232	1.60	0.983	1.00	1.00	1.00	1.00	1.00	1.00	1.00	17.60	1,231.50	4561.28	5.26	107.42	464.00
+0.60D+0.70E+H	Length = 12.0 ft	1	0.069	0.059	1.60	0.983	1.00	1.00	1.00	1.00	1.00	1.00	1.00	4.47	312.81	4561.28	1.34	27.40	464.00

**Overall Maximum Deflections**

Load Combination	Span	Max. "-" Defl	Location in Span	Load Combination	Max. "+" Defl	Location in Span
+D+0.750L+0.750S+0.5250E+H	1	0.1989	6.044		0.0000	0.000

**Vertical Reactions**

Load Combination	Support notation : Far left is #'		Values in KIPS	
	Support 1	Support 2		
Overall MAXimum	6.494	14.157		
Overall MINimum	3.300	7.800		
+D+H	2.759	6.357		
+D+L+H	4.439	8.037		
+D+Lr+H	2.759	6.357		
+D+S+H	6.059	14.157		
+D+0.750Lr+0.750L+H	4.019	7.617		
+D+0.750L+0.750S+H	6.494	13.467		
+D+0.60W+H	2.759	6.357		
+D+0.750Lr+0.750L+0.450W+H	4.019	7.617		
+D+0.750L+0.750S+0.450W+H	6.494	13.467		
+0.60D+0.60W+0.60H	1.655	3.814		
+D+0.70E+0.60H	2.759	6.357		
+D+0.750L+0.750S+0.5250E+H	6.494	13.467		
+0.60D+0.70E+H	1.655	3.814		
D Only	2.759	6.357		
Lr Only				
L Only	1.680	1.680		
S Only	3.300	7.800		
W Only				
E Only				
H Only				

**Wood Beam**

Lic. # : KW-06009431

**DESCRIPTIO BM#10**

**CODE REFERENCES**

Calculations per NDS 2015, IBC 2015, CBC 2016, ASCE 7-10  
 Load Combination Set : ASCE 7-16

**Material Properties**

Analysis Method	Allowable Stress Design	Fb +	2,900.0 psi	E : Modulus of Elasticity	
Load Combination	ASCE 7-16	Fb -	2,900.0 psi	Ebend- xx	2,000.0ksi
		Fc - Prll	2,900.0 psi	Eminbend - x	1,016.54ksi
Wood Species	Trus Joist	Fc - Perp	625.0 psi		
Wood Grade	Parallam PSL 2.0E	Fv	290.0 psi		
		Ft	2,025.0 psi	Density	45.070pcf
Beam Bracing	Beam is Fully Braced against lateral-torsional buckling				

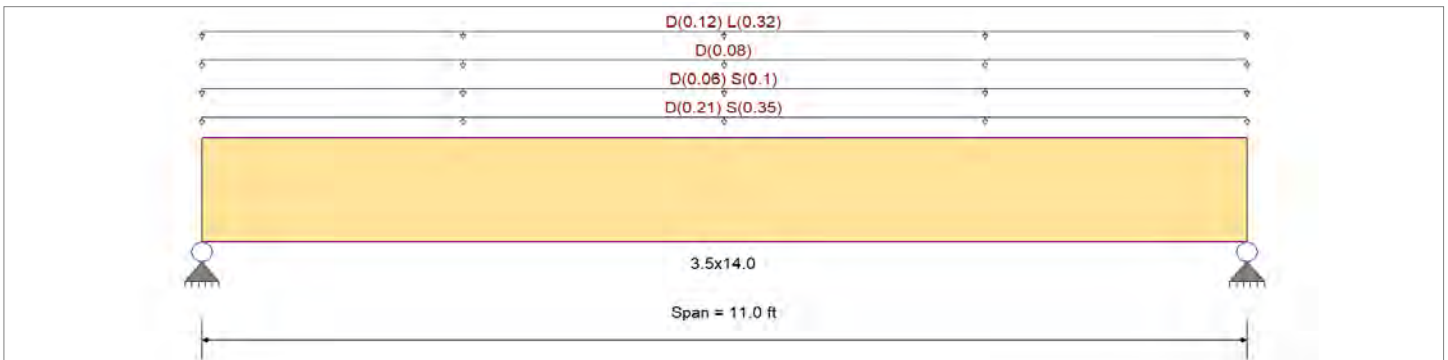

**Applied Loads**

Service loads entered. Load Factors will be applied for calculations.

Beam self weight calculated and added to loads

- Uniform Load : D = 0.0150, S = 0.0250 ksf, Tributary Width = 14.0 ft, (UPPER ROOF)
- Uniform Load : D = 0.0150, S = 0.0250 ksf, Tributary Width = 4.0 ft, (LOWER ROOF)
- Uniform Load : D = 0.010 ksf, Tributary Width = 8.0 ft, (WALL)
- Uniform Load : D = 0.0150, L = 0.040 ksf, Tributary Width = 8.0 ft, (FLOOR)

**DESIGN SUMMARY**

**Design OK**

Maximum Bending Stress Ratio =	<b>0.515</b> : 1	Maximum Shear Stress Ratio =	<b>0.423</b> : 1
Section used for this span =	<b>3.5x14.0</b>	Section used for this span =	<b>3.5x14.0</b>
=	1,687.21 psi	=	141.07 psi
=	3,278.42 psi	=	333.50 psi
Load Combination	+D+0.750L+0.750S+H	Load Combination	+D+0.750L+0.750S+H
Location of maximum on span =	5.500ft	Location of maximum on span =	9.836 ft
Span # where maximum occurs =	Span # 1	Span # where maximum occurs =	Span # 1
<b>Maximum Deflection</b>			
Max Downward Transient Deflection	0.093 in	Ratio =	<b>1417</b> >=360
Max Upward Transient Deflection	0.000 in	Ratio =	<b>0</b> <360
Max Downward Total Deflection	0.220 in	Ratio =	<b>599</b> >=240
Max Upward Total Deflection	0.000 in	Ratio =	<b>0</b> <240

**Maximum Forces & Stresses for Load Combinations**

Load Combination	Segment Length	Span #	Max Stress Ratios								Moment Values			Shear Values				
			M	V	C <sub>d</sub>	C <sub>F/V</sub>	C <sub>i</sub>	C <sub>r</sub>	C <sub>m</sub>	C <sub>t</sub>	C <sub>L</sub>	M	fb	F'b	V	fv	F'v	
+D+H	Length = 11.0 ft	1	0.300	0.247	0.90	0.983	1.00	1.00	1.00	1.00	1.00	7.34	770.45	2565.72	0.00	0.00	0.00	261.00
+D+L+H	Length = 11.0 ft	1	0.448	0.369	1.00	0.983	1.00	1.00	1.00	1.00	1.00	12.18	1,278.44	2850.80	0.00	0.00	0.00	290.00
+D+Lr+H	Length = 11.0 ft	1	0.216	0.178	1.25	0.983	1.00	1.00	1.00	1.00	1.00	7.34	770.45	3563.50	0.00	0.00	0.00	362.50
+D+S+H	Length = 11.0 ft	1	0.453	0.372	1.15	0.983	1.00	1.00	1.00	1.00	1.00	14.15	1,484.81	3278.42	0.00	0.00	0.00	333.50
+D+0.750Lr+0.750L+H	Length = 11.0 ft	1	0.323	0.266	1.25	0.983	1.00	1.00	1.00	1.00	1.00	10.97	1,151.44	3563.50	0.00	0.00	0.00	362.50

**Wood Beam**

Lic. # : KW-06009431

**DESCRIPTIO BM#10**

Load Combination	Segment Length	Span #	Max Stress Ratios								Moment Values			Shear Values								
			M	V	C <sub>d</sub>	C <sub>F/V</sub>	C <sub>i</sub>	C <sub>r</sub>	C <sub>m</sub>	C <sub>t</sub>	C <sub>L</sub>	M	fb	F'b	V	fv	Fv					
+D+0.750L+0.750S+H	Length = 11.0 ft	1	0.515	0.423	1.15	0.983	1.00	1.00	1.00	1.00	1.00	1.00	1.00	16.08	1,687.21	3278.42	0.00	0.00	0.00	0.00	141.07	333.50
+D+0.60W+H	Length = 11.0 ft	1	0.169	0.139	1.60	0.983	1.00	1.00	1.00	1.00	1.00	1.00	1.00	7.34	770.45	4561.28	0.00	0.00	0.00	0.00	64.42	464.00
+D+0.750Lr+0.750L+0.450W-	Length = 11.0 ft	1	0.252	0.207	1.60	0.983	1.00	1.00	1.00	1.00	1.00	1.00	1.00	10.97	1,151.44	4561.28	0.00	0.00	0.00	0.00	96.27	464.00
+D+0.750L+0.750S+0.450W+	Length = 11.0 ft	1	0.370	0.304	1.60	0.983	1.00	1.00	1.00	1.00	1.00	1.00	1.00	16.08	1,687.21	4561.28	0.00	0.00	0.00	4.61	141.07	464.00
+0.60D+0.60W+0.60H	Length = 11.0 ft	1	0.101	0.083	1.60	0.983	1.00	1.00	1.00	1.00	1.00	1.00	1.00	4.40	462.27	4561.28	0.00	0.00	0.00	1.26	38.65	464.00
+D+0.70E+0.60H	Length = 11.0 ft	1	0.169	0.139	1.60	0.983	1.00	1.00	1.00	1.00	1.00	1.00	1.00	7.34	770.45	4561.28	0.00	0.00	0.00	2.10	64.42	464.00
+D+0.750L+0.750S+0.5250E-	Length = 11.0 ft	1	0.370	0.304	1.60	0.983	1.00	1.00	1.00	1.00	1.00	1.00	1.00	16.08	1,687.21	4561.28	0.00	0.00	0.00	4.61	141.07	464.00
+0.60D+0.70E+H	Length = 11.0 ft	1	0.101	0.083	1.60	0.983	1.00	1.00	1.00	1.00	1.00	1.00	1.00	4.40	462.27	4561.28	0.00	0.00	0.00	1.26	38.65	464.00

**Overall Maximum Deflections**

Load Combination	Span	Max. "-" Defl	Location in Span	Load Combination	Max. "+" Defl	Location in Span
+D+0.750L+0.750S+0.5250E+H	1	0.2200	5.540		0.0000	0.000

**Vertical Reactions**

Load Combination	Support notation : Far left is #'		Values in KIPS	
	Support 1	Support 2		
Overall MAXimum	5.846	5.846		
Overall MINimum	2.475	2.475		
+D+H	2.669	2.669		
+D+L+H	4.429	4.429		
+D+Lr+H	2.669	2.669		
+D+S+H	5.144	5.144		
+D+0.750Lr+0.750L+H	3.989	3.989		
+D+0.750L+0.750S+H	5.846	5.846		
+D+0.60W+H	2.669	2.669		
+D+0.750Lr+0.750L+0.450W+H	3.989	3.989		
+D+0.750L+0.750S+0.450W+H	5.846	5.846		
+0.60D+0.60W+0.60H	1.602	1.602		
+D+0.70E+0.60H	2.669	2.669		
+D+0.750L+0.750S+0.5250E+H	5.846	5.846		
+0.60D+0.70E+H	1.602	1.602		
D Only	2.669	2.669		
Lr Only				
L Only	1.760	1.760		
S Only	2.475	2.475		
W Only				
E Only				
H Only				

## Wood Beam

Lic. # : KW-06009431

### DESCRIPTIO BM#11

### CODE REFERENCES

Calculations per NDS 2015, IBC 2015, CBC 2016, ASCE 7-10  
Load Combination Set : ASCE 7-16

### Material Properties

Analysis Method	Allowable Stress Design	Fb +	2,900.0 psi	E : Modulus of Elasticity	
Load Combination	ASCE 7-16	Fb -	2,900.0 psi	Ebend- xx	2,000.0ksi
Wood Species	Trus Joist	Fc - Prll	2,900.0 psi	Eminbend - x	1,016.54ksi
Wood Grade	Parallam PSL 2.0E	Fc - Perp	625.0 psi		
		Fv	290.0 psi		
		Ft	2,025.0 psi	Density	45.070pcf
Beam Bracing	Beam is Fully Braced against lateral-torsional buckling				

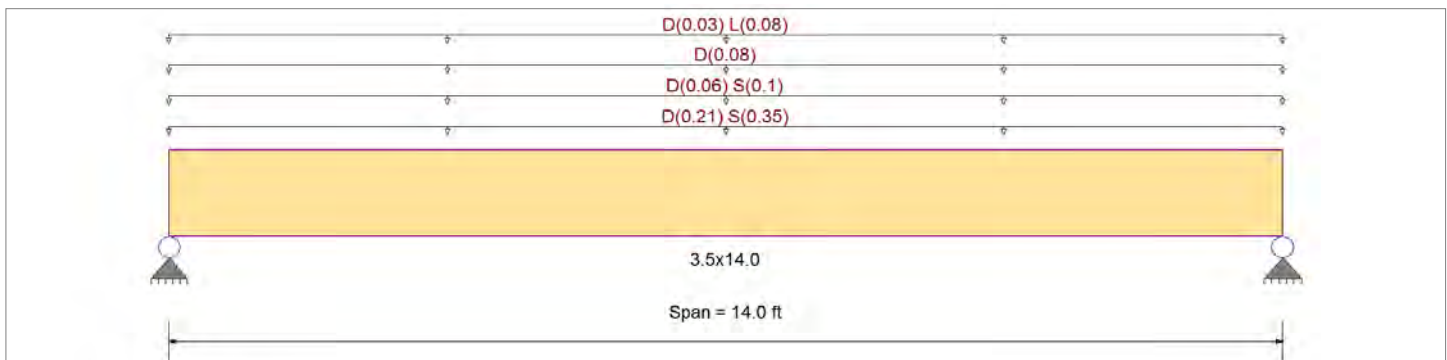

### Applied Loads

Service loads entered. Load Factors will be applied for calculations.

Beam self weight calculated and added to loads

- Uniform Load : D = 0.0150, S = 0.0250 ksf, Tributary Width = 14.0 ft, (UPPER ROOF)
- Uniform Load : D = 0.0150, S = 0.0250 ksf, Tributary Width = 4.0 ft, (LOWER ROOF)
- Uniform Load : D = 0.010 ksf, Tributary Width = 8.0 ft, (WALL)
- Uniform Load : D = 0.0150, L = 0.040 ksf, Tributary Width = 2.0 ft, (FLOOR)

### DESIGN SUMMARY

**Design OK**

Maximum Bending Stress Ratio	=	<b>0.663</b> < 1	Maximum Shear Stress Ratio	=	<b>0.456</b> < 1
Section used for this span	=	<b>3.5x14.0</b>	Section used for this span	=	<b>3.5x14.0</b>
	=	2,173.72psi		=	152.05 psi
	=	3,278.42psi		=	333.50 psi
Load Combination	=	+D+S+H	Load Combination	=	+D+S+H
Location of maximum on span	=	7.000ft	Location of maximum on span	=	12.876 ft
Span # where maximum occurs	=	Span # 1	Span # where maximum occurs	=	Span # 1
<b>Maximum Deflection</b>					
Max Downward Transient Deflection		0.244 in	Ratio =		<b>687</b> >=360
Max Upward Transient Deflection		0.000 in	Ratio =		<b>0</b> <360
Max Downward Total Deflection		0.459 in	Ratio =		<b>365</b> >=240
Max Upward Total Deflection		0.000 in	Ratio =		<b>0</b> <240

### Maximum Forces & Stresses for Load Combinations

Load Combination	Segment Length	Span #	Max Stress Ratios								Moment Values			Shear Values						
			M	V	C <sub>d</sub>	C <sub>F/V</sub>	C <sub>i</sub>	C <sub>r</sub>	C <sub>m</sub>	C <sub>t</sub>	C <sub>L</sub>	M	fb	F'b	V	fv	F'v			
+D+H	Length = 14.0 ft	1	0.396	0.272	0.90	0.983	1.00	1.00	1.00	1.00	1.00	9.69	1,016.58	2565.72	0.00	0.00	0.00	2.32	71.11	261.00
+D+L+H	Length = 14.0 ft	1	0.429	0.295	1.00	0.983	1.00	1.00	1.00	1.00	1.00	11.65	1,222.29	2850.80	0.00	0.00	0.00	2.79	85.50	290.00
+D+Lr+H	Length = 14.0 ft	1	0.285	0.196	1.25	0.983	1.00	1.00	1.00	1.00	1.00	9.69	1,016.58	3563.50	0.00	0.00	0.00	2.32	71.11	362.50
+D+S+H	Length = 14.0 ft	1	0.663	0.456	1.15	0.983	1.00	1.00	1.00	1.00	1.00	20.71	2,173.72	3278.42	0.00	0.00	0.00	4.97	152.05	333.50
+D+0.750Lr+0.750L+H	Length = 14.0 ft	1	0.329	0.226	1.25	0.983	1.00	1.00	1.00	1.00	1.00	11.16	1,170.86	3563.50	0.00	0.00	0.00	2.68	81.90	362.50

**Wood Beam**

Lic. # : KW-06009431

**DESCRIPTIO BM#11**

Load Combination	Segment Length	Span #	Max Stress Ratios								Moment Values			Shear Values								
			M	V	C <sub>d</sub>	C <sub>F/V</sub>	C <sub>i</sub>	C <sub>r</sub>	C <sub>m</sub>	C <sub>t</sub>	C <sub>L</sub>	M	fb	F'b	V	f <sub>v</sub>	F <sub>v</sub>					
+D+0.750L+0.750S+H	Length = 14.0 ft	1	0.622	0.428	1.15	0.983	1.00	1.00	1.00	1.00	1.00	1.00	1.00	19.42	2,038.72	3278.42	0.00	0.00	0.00	4.66	142.61	333.50
+D+0.60W+H	Length = 14.0 ft	1	0.223	0.153	1.60	0.983	1.00	1.00	1.00	1.00	1.00	1.00	1.00	9.69	1,016.58	4561.28	0.00	0.00	0.00	2.32	71.11	464.00
+D+0.750Lr+0.750L+0.450W-	Length = 14.0 ft	1	0.257	0.177	1.60	0.983	1.00	1.00	1.00	1.00	1.00	1.00	1.00	11.16	1,170.86	4561.28	0.00	0.00	0.00	2.68	81.90	464.00
+D+0.750L+0.750S+0.450W+	Length = 14.0 ft	1	0.447	0.307	1.60	0.983	1.00	1.00	1.00	1.00	1.00	1.00	1.00	19.42	2,038.72	4561.28	0.00	0.00	0.00	4.66	142.61	464.00
+0.60D+0.60W+0.60H	Length = 14.0 ft	1	0.134	0.092	1.60	0.983	1.00	1.00	1.00	1.00	1.00	1.00	1.00	5.81	609.95	4561.28	0.00	0.00	0.00	1.39	42.67	464.00
+D+0.70E+0.60H	Length = 14.0 ft	1	0.223	0.153	1.60	0.983	1.00	1.00	1.00	1.00	1.00	1.00	1.00	9.69	1,016.58	4561.28	0.00	0.00	0.00	2.32	71.11	464.00
+D+0.750L+0.750S+0.5250E-	Length = 14.0 ft	1	0.447	0.307	1.60	0.983	1.00	1.00	1.00	1.00	1.00	1.00	1.00	19.42	2,038.72	4561.28	0.00	0.00	0.00	4.66	142.61	464.00
+0.60D+0.70E+H	Length = 14.0 ft	1	0.134	0.092	1.60	0.983	1.00	1.00	1.00	1.00	1.00	1.00	1.00	5.81	609.95	4561.28	0.00	0.00	0.00	1.39	42.67	464.00

**Overall Maximum Deflections**

Load Combination	Span	Max. "-" Defl	Location in Span	Load Combination	Max. "+" Defl	Location in Span
+D+S+H	1	0.4591	7.051		0.0000	0.000

**Vertical Reactions**

Load Combination	Support notation : Far left is #'		Values in KIPS	
	Support 1	Support 2		
Overall MAXimum	5.917	5.917		
Overall MINimum	3.150	3.150		
+D+H	2.767	2.767		
+D+L+H	3.327	3.327		
+D+Lr+H	2.767	2.767		
+D+S+H	5.917	5.917		
+D+0.750Lr+0.750L+H	3.187	3.187		
+D+0.750L+0.750S+H	5.550	5.550		
+D+0.60W+H	2.767	2.767		
+D+0.750Lr+0.750L+0.450W+H	3.187	3.187		
+D+0.750L+0.750S+0.450W+H	5.550	5.550		
+0.60D+0.60W+0.60H	1.660	1.660		
+D+0.70E+0.60H	2.767	2.767		
+D+0.750L+0.750S+0.5250E+H	5.550	5.550		
+0.60D+0.70E+H	1.660	1.660		
D Only	2.767	2.767		
Lr Only				
L Only	0.560	0.560		
S Only	3.150	3.150		
W Only				
E Only				
H Only				



## Wood Beam

Lic. # : KW-06009431

### DESCRIPTION BM#12

### CODE REFERENCES

Calculations per NDS 2015, IBC 2015, CBC 2016, ASCE 7-10  
Load Combination Set : ASCE 7-16

### Material Properties

Analysis Method	Allowable Stress Design	Fb +	2,900.0 psi	E : Modulus of Elasticity	
Load Combination	ASCE 7-16	Fb -	2,900.0 psi	Ebend- xx	2,000.0ksi
		Fc - Prll	2,900.0 psi	Eminbend - x	1,016.54ksi
Wood Species	Trus Joist	Fc - Perp	625.0 psi		
Wood Grade	Parallam PSL 2.0E	Fv	290.0 psi		
		Ft	2,025.0 psi	Density	45.070pcf
Beam Bracing	Beam is Fully Braced against lateral-torsional buckling				

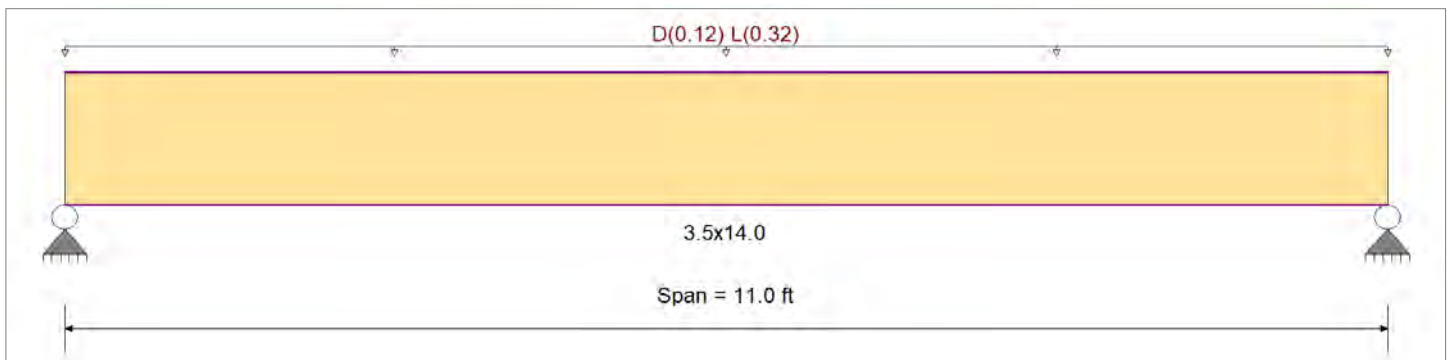

### Applied Loads

Service loads entered. Load Factors will be applied for calculations.

Beam self weight calculated and added to loads

Uniform Load : D = 0.0150, L = 0.040 ksf, Tributary Width = 8.0 ft, (FLOOR)

### DESIGN SUMMARY

**Design OK**

Maximum Bending Stress Ratio	=	<b>0.254</b> < 1	Maximum Shear Stress Ratio	=	<b>0.208</b> < 1
Section used for this span	=	<b>3.5x14.0</b>	Section used for this span	=	<b>3.5x14.0</b>
	=	722.83psi		=	60.44 psi
	=	2,850.80psi		=	290.00 psi
Load Combination	=	+D+L+H	Load Combination	=	+D+L+H
Location of maximum on span	=	5.500ft	Location of maximum on span	=	9.836 ft
Span # where maximum occurs	=	Span # 1	Span # where maximum occurs	=	Span # 1
<b>Maximum Deflection</b>					
Max Downward Transient Deflection		0.066 in	Ratio =		1992 >= 360
Max Upward Transient Deflection		0.000 in	Ratio =		0 < 360
Max Downward Total Deflection		0.094 in	Ratio =		1400 >= 240
Max Upward Total Deflection		0.000 in	Ratio =		0 < 240

### Maximum Forces & Stresses for Load Combinations

Load Combination	Segment Length	Span #	Max Stress Ratios									Moment Values			Shear Values				
			M	V	C <sub>d</sub>	C <sub>F/V</sub>	C <sub>i</sub>	C <sub>r</sub>	C <sub>m</sub>	C <sub>t</sub>	C <sub>L</sub>	M	fb	F'b	V	fv	F'v		
+D+H	Length = 11.0 ft	1	0.084	0.069	0.90	0.983	1.00	1.00	1.00	1.00	1.00	1.00	1.00	2.05	214.84	2565.72	0.59	17.96	261.00
+D+L+H	Length = 11.0 ft	1	0.254	0.208	1.00	0.983	1.00	1.00	1.00	1.00	1.00	1.00	1.00	6.89	722.83	2850.80	1.97	60.44	290.00
+D+Lr+H	Length = 11.0 ft	1	0.060	0.050	1.25	0.983	1.00	1.00	1.00	1.00	1.00	1.00	1.00	2.05	214.84	3563.50	0.59	17.96	362.50
+D+S+H	Length = 11.0 ft	1	0.066	0.054	1.15	0.983	1.00	1.00	1.00	1.00	1.00	1.00	1.00	2.05	214.84	3278.42	0.59	17.96	333.50
+D+0.750Lr+0.750L+H	Length = 11.0 ft	1	0.167	0.137	1.25	0.983	1.00	1.00	1.00	1.00	1.00	1.00	1.00	5.68	595.83	3563.50	1.63	49.82	362.50
+D+0.750L+0.750S+H	Length = 11.0 ft	1	0.182	0.149	1.15	0.983	1.00	1.00	1.00	1.00	1.00	1.00	1.00	5.68	595.83	3278.42	1.63	49.82	333.50
+D+0.60W+H						0.983	1.00	1.00	1.00	1.00	1.00	1.00			0.00		0.00	0.00	0.00

**Wood Beam**

Lic. # : KW-06009431

**DESCRIPTIO BM#12**

Load Combination	Segment Length	Span #	Max Stress Ratios									Moment Values			Shear Values				
			M	V	C <sub>d</sub>	C <sub>F/V</sub>	C <sub>i</sub>	C <sub>r</sub>	C <sub>m</sub>	C <sub>t</sub>	C <sub>L</sub>	M	fb	F'b	V	f <sub>v</sub>	F'v		
Length = 11.0 ft	1	0.047	0.039	1.60	0.983	1.00	1.00	1.00	1.00	1.00	1.00	1.00	1.00	2.05	214.84	4561.28	0.59	17.96	464.00
+D+0.750Lr+0.750L+0.450W-				0.983	1.00	1.00	1.00	1.00	1.00	1.00	1.00	1.00	1.00			0.00	0.00	0.00	0.00
Length = 11.0 ft	1	0.131	0.107	1.60	0.983	1.00	1.00	1.00	1.00	1.00	1.00	1.00	1.00	5.68	595.83	4561.28	1.63	49.82	464.00
+D+0.750L+0.750S+0.450W+				0.983	1.00	1.00	1.00	1.00	1.00	1.00	1.00	1.00	1.00			0.00	0.00	0.00	0.00
Length = 11.0 ft	1	0.131	0.107	1.60	0.983	1.00	1.00	1.00	1.00	1.00	1.00	1.00	1.00	5.68	595.83	4561.28	1.63	49.82	464.00
+0.60D+0.60W+0.60H				0.983	1.00	1.00	1.00	1.00	1.00	1.00	1.00	1.00	1.00			0.00	0.00	0.00	0.00
Length = 11.0 ft	1	0.028	0.023	1.60	0.983	1.00	1.00	1.00	1.00	1.00	1.00	1.00	1.00	1.23	128.90	4561.28	0.35	10.78	464.00
+D+0.70E+0.60H				0.983	1.00	1.00	1.00	1.00	1.00	1.00	1.00	1.00	1.00			0.00	0.00	0.00	0.00
Length = 11.0 ft	1	0.047	0.039	1.60	0.983	1.00	1.00	1.00	1.00	1.00	1.00	1.00	1.00	2.05	214.84	4561.28	0.59	17.96	464.00
+D+0.750L+0.750S+0.5250E-				0.983	1.00	1.00	1.00	1.00	1.00	1.00	1.00	1.00	1.00			0.00	0.00	0.00	0.00
Length = 11.0 ft	1	0.131	0.107	1.60	0.983	1.00	1.00	1.00	1.00	1.00	1.00	1.00	1.00	5.68	595.83	4561.28	1.63	49.82	464.00
+0.60D+0.70E+H				0.983	1.00	1.00	1.00	1.00	1.00	1.00	1.00	1.00	1.00			0.00	0.00	0.00	0.00
Length = 11.0 ft	1	0.028	0.023	1.60	0.983	1.00	1.00	1.00	1.00	1.00	1.00	1.00	1.00	1.23	128.90	4561.28	0.35	10.78	464.00

**Overall Maximum Deflections**

Load Combination	Span	Max. "-" Defl	Location in Span	Load Combination	Max. "+" Defl	Location in Span
+D+L+H	1	0.0943	5.540		0.0000	0.000

**Vertical Reactions**

Support notation : Far left is #'

Values in KIPS

Load Combination	Support 1	Support 2
Overall MAXimum	2.504	2.504
Overall MINimum	1.760	1.760
+D+H	0.744	0.744
+D+L+H	2.504	2.504
+D+Lr+H	0.744	0.744
+D+S+H	0.744	0.744
+D+0.750Lr+0.750L+H	2.064	2.064
+D+0.750L+0.750S+H	2.064	2.064
+D+0.60W+H	0.744	0.744
+D+0.750Lr+0.750L+0.450W+H	2.064	2.064
+D+0.750L+0.750S+0.450W+H	2.064	2.064
+0.60D+0.60W+0.60H	0.447	0.447
+D+0.70E+0.60H	0.744	0.744
+D+0.750L+0.750S+0.5250E+H	2.064	2.064
+0.60D+0.70E+H	0.447	0.447
D Only	0.744	0.744
Lr Only		
L Only	1.760	1.760
S Only		
W Only		
E Only		
H Only		

## Wood Beam

Lic. # : KW-06009431

### DESCRIPTIO BM#13

### CODE REFERENCES

Calculations per NDS 2015, IBC 2015, CBC 2016, ASCE 7-10  
Load Combination Set : ASCE 7-16

### Material Properties

Analysis Method	Allowable Stress Design	Fb +	2,900.0 psi	E : Modulus of Elasticity	
Load Combination	ASCE 7-16	Fb -	2,900.0 psi	Ebend- xx	2,000.0ksi
		Fc - Prll	2,900.0 psi	Eminbend - x	1,016.54ksi
Wood Species	Trus Joist	Fc - Perp	625.0 psi		
Wood Grade	Parallam PSL 2.0E	Fv	290.0 psi		
		Ft	2,025.0 psi	Density	45.070pcf
Beam Bracing	Beam is Fully Braced against lateral-torsional buckling				

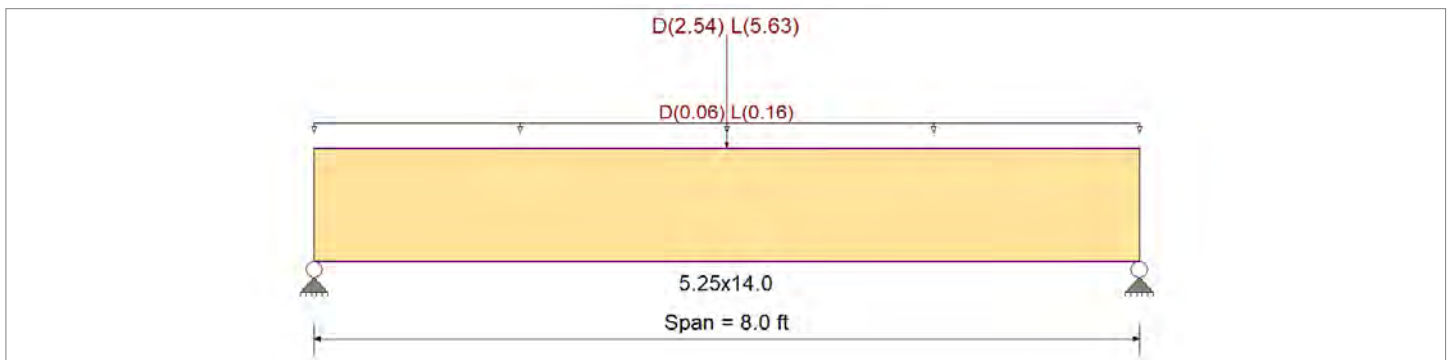

### Applied Loads

Service loads entered. Load Factors will be applied for calculations.

Beam self weight calculated and added to loads

Uniform Load : D = 0.0150, L = 0.040 ksf, Tributary Width = 4.0 ft, (FLOOR)

Point Load : D = 2.540, L = 5.630 k @ 4.0 ft, (BM#5)

### DESIGN SUMMARY

**Design OK**

Maximum Bending Stress Ratio	=	<b>0.449</b>	1	Maximum Shear Stress Ratio	=	<b>0.336</b>	: 1
Section used for this span	=	<b>5.25x14.0</b>		Section used for this span	=	<b>5.25x14.0</b>	
	=	1,279.35psi			=	97.56 psi	
	=	2,850.80psi			=	290.00 psi	
Load Combination	=	<b>+D+L+H</b>		Load Combination	=	<b>+D+L+H</b>	
Location of maximum on span	=	4.000ft		Location of maximum on span	=	6.861 ft	
Span # where maximum occurs	=	Span # 1		Span # where maximum occurs	=	Span # 1	
<b>Maximum Deflection</b>							
Max Downward Transient Deflection		0.050 in	Ratio =	1934	>=	360	
Max Upward Transient Deflection		0.000 in	Ratio =	0	<	360	
Max Downward Total Deflection		0.072 in	Ratio =	1325	>=	240	
Max Upward Total Deflection		0.000 in	Ratio =	0	<	240	

### Maximum Forces & Stresses for Load Combinations

Load Combination	Segment Length	Span #	Max Stress Ratios								Moment Values			Shear Values								
			M	V	C <sub>d</sub>	C <sub>F/V</sub>	C <sub>i</sub>	C <sub>r</sub>	C <sub>m</sub>	C <sub>t</sub>	C <sub>L</sub>	M	fb	F'b	V	fv	F'v					
+D+H	Length = 8.0 ft	1	0.157	0.118	0.90	0.983	1.00	1.00	1.00	1.00	1.00	1.00	1.00	5.74	401.92	2565.72	0.00	0.00	0.00	1.51	30.77	261.00
+D+L+H	Length = 8.0 ft	1	0.449	0.336	1.00	0.983	1.00	1.00	1.00	1.00	1.00	1.00	1.00	18.28	1,279.35	2850.80	0.00	0.00	0.00	4.78	97.56	290.00
+D+Lr+H	Length = 8.0 ft	1	0.113	0.085	1.25	0.983	1.00	1.00	1.00	1.00	1.00	1.00	1.00	5.74	401.92	3563.50	0.00	0.00	0.00	1.51	30.77	362.50
+D+S+H	Length = 8.0 ft	1	0.123	0.092	1.15	0.983	1.00	1.00	1.00	1.00	1.00	1.00	1.00	5.74	401.92	3278.42	0.00	0.00	0.00	1.51	30.77	333.50
+D+0.750Lr+0.750L+H	Length = 8.0 ft	1	0.297	0.223	1.25	0.983	1.00	1.00	1.00	1.00	1.00	1.00	1.00	15.15	1,059.99	3563.50	0.00	0.00	0.00	3.96	80.86	362.50
+D+0.750L+0.750S+H	Length = 8.0 ft	1	0.323	0.242	1.15	0.983	1.00	1.00	1.00	1.00	1.00	1.00	1.00	15.15	1,059.99	3278.42	0.00	0.00	0.00	3.96	80.86	333.50

**Wood Beam**

Lic. # : KW-06009431

**DESCRIPTIO BM#13**

Load Combination Segment Length	Span #	Max Stress Ratios									Moment Values			Shear Values			
		M	V	C <sub>d</sub>	C <sub>F/V</sub>	C <sub>i</sub>	C <sub>r</sub>	C <sub>m</sub>	C <sub>t</sub>	C <sub>L</sub>	M	fb	F'b	V	fv	Fv	
+D+0.60W+H Length = 8.0 ft	1	0.088	0.066	1.60	0.983	1.00	1.00	1.00	1.00	1.00	1.00	5.74	401.92	4561.28	0.00	0.00	0.00
+D+0.750Lr+0.750L+0.450W- Length = 8.0 ft	1	0.232	0.174	1.60	0.983	1.00	1.00	1.00	1.00	1.00	1.00	15.15	1,059.99	4561.28	0.00	0.00	0.00
+D+0.750L+0.750S+0.450W+ Length = 8.0 ft	1	0.232	0.174	1.60	0.983	1.00	1.00	1.00	1.00	1.00	1.00	15.15	1,059.99	4561.28	0.00	0.00	0.00
+0.60D+0.60W+0.60H Length = 8.0 ft	1	0.053	0.040	1.60	0.983	1.00	1.00	1.00	1.00	1.00	1.00	3.45	241.15	4561.28	0.00	0.00	0.00
+D+0.70E+0.60H Length = 8.0 ft	1	0.088	0.066	1.60	0.983	1.00	1.00	1.00	1.00	1.00	1.00	5.74	401.92	4561.28	0.00	0.00	0.00
+D+0.750L+0.750S+0.5250E- Length = 8.0 ft	1	0.232	0.174	1.60	0.983	1.00	1.00	1.00	1.00	1.00	1.00	15.15	1,059.99	4561.28	0.00	0.00	0.00
+0.60D+0.70E+H Length = 8.0 ft	1	0.053	0.040	1.60	0.983	1.00	1.00	1.00	1.00	1.00	1.00	3.45	241.15	4561.28	0.00	0.00	0.00

**Overall Maximum Deflections**

Load Combination	Span	Max. "-" Defl	Location in Span	Load Combination	Max. "+" Defl	Location in Span
+D+L+H	1	0.0724	4.029		0.0000	0.000

**Vertical Reactions**

Load Combination	Support notation : Far left is #'		Values in KIPS	
	Support 1	Support 2		
Overall MAXimum	5.057	5.057		
Overall MINimum	3.455	3.455		
+D+H	1.602	1.602		
+D+L+H	5.057	5.057		
+D+Lr+H	1.602	1.602		
+D+S+H	1.602	1.602		
+D+0.750Lr+0.750L+H	4.193	4.193		
+D+0.750L+0.750S+H	4.193	4.193		
+D+0.60W+H	1.602	1.602		
+D+0.750Lr+0.750L+0.450W+H	4.193	4.193		
+D+0.750L+0.750S+0.450W+H	4.193	4.193		
+0.60D+0.60W+0.60H	0.961	0.961		
+D+0.70E+0.60H	1.602	1.602		
+D+0.750L+0.750S+0.5250E+H	4.193	4.193		
+0.60D+0.70E+H	0.961	0.961		
D Only	1.602	1.602		
Lr Only				
L Only	3.455	3.455		
S Only				
W Only				
E Only				
H Only				

## Wood Beam

Lic. #: KW-06009431

### DESCRIPTIO BM#14

### CODE REFERENCES

Calculations per NDS 2015, IBC 2015, CBC 2016, ASCE 7-10  
Load Combination Set : ASCE 7-16

### Material Properties

Analysis Method	Allowable Stress Design	Fb +	2,900.0 psi	E : Modulus of Elasti	
Load Combinati	ASCE 7-16	Fb -	2,900.0 psi	Ebend- xx	2,000.0ksi
		Fc - Prll	2,900.0 psi	Eminbend - x	1,016.54ksi
Wood Species	Trus Joist	Fc - Perp	625.0 psi		
Wood Grade	Parallam PSL 2.0E	Fv	290.0 psi		
		Ft	2,025.0 psi	Density	45.070pcf
Beam Bracing	Beam is Fully Braced against lateral-torsional buckling				

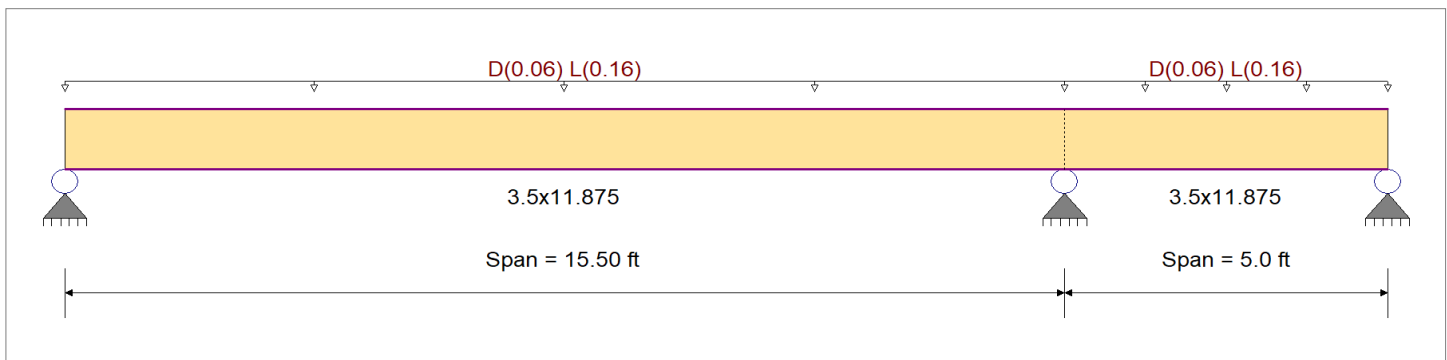

### Applied Loads

Service loads entered. Load Factors will be applied for calculations.

Beam self weight calculated and added to loads

Load for Span Number 1

Uniform Load : D = 0.0150, L = 0.040 ksf, Tributary Width = 4.0 ft, (FLOOR)

Load for Span Number 2

Uniform Load : D = 0.0150, L = 0.040 ksf, Tributary Width = 4.0 ft, (FLOOR)

### DESIGN SUMMARY

**Design OK**

Maximum Bending Stress Ratio	=	<b>0.275</b>	1	Maximum Shear Stress Ratio	=	<b>0.241</b>	: 1
Section used for this span	=	<b>3.5x11.875</b>		Section used for this span	=	<b>3.5x11.875</b>	
	=	797.74	psi		=	69.89	psi
	=	2,900.00	psi		=	290.00	psi
Load Combination	=	<b>+D+L+H</b>		Load Combination	=	<b>+D+L+H</b>	
Location of maximum on span	=	15.500ft		Location of maximum on span	=	14.547 ft	
Span # where maximum occurs	=	Span # 1		Span # where maximum occurs	=	Span # 1	
<b>Maximum Deflection</b>							
Max Downward Transient Deflection		0.116	in	Ratio =	<b>1605</b>	>=	360
Max Upward Transient Deflection		-0.009	in	Ratio =	<b>7001</b>	>=	360
Max Downward Total Deflection		0.169	in	Ratio =	<b>1102</b>	>=	240
Max Upward Total Deflection		-0.012	in	Ratio =	<b>4808</b>	>=	240

### Maximum Forces & Stresses for Load Combinations

Load Combination	Segment Length	Span #	Max Stress Ratios								Moment Values			Shear Values						
			M	V	C <sub>d</sub>	C <sub>F/V</sub>	C <sub>i</sub>	C <sub>r</sub>	C <sub>m</sub>	C <sub>t</sub>	C <sub>L</sub>	M	fb	F'b	V	f <sub>v</sub>	F'v			
+D+H	Length = 15.50 ft	1	0.096	0.084	0.90	1.000	1.00	1.00	1.00	1.00	1.00	1.71	249.95	2610.00	0.00	0.00	0.00	0.00	0.00	261.00
	Length = 5.0 ft	2	0.096	0.084	0.90	1.000	1.00	1.00	1.00	1.00	1.00	1.71	249.95	2610.00	0.45	21.90	261.00	0.00	0.00	0.00
+D+L+H	Length = 15.50 ft	1	0.275	0.241	1.00	1.000	1.00	1.00	1.00	1.00	1.00	5.47	797.74	2900.00	1.94	69.89	290.00	0.00	0.00	0.00
	Length = 5.0 ft	2	0.275	0.241	1.00	1.000	1.00	1.00	1.00	1.00	1.00	5.47	797.74	2900.00	1.45	69.89	290.00	0.00	0.00	0.00
+D+Lr+H	Length = 15.50 ft	1	0.069	0.060	1.25	1.000	1.00	1.00	1.00	1.00	1.00	1.71	249.95	3625.00	0.61	21.90	362.50	0.00	0.00	0.00
	Length = 5.0 ft	2	0.069	0.060	1.25	1.000	1.00	1.00	1.00	1.00	1.00	1.71	249.95	3625.00	0.45	21.90	362.50	0.00	0.00	0.00
+D+S+H					1.000	1.00	1.00	1.00	1.00	1.00				0.00	0.00	0.00	0.00	0.00	0.00	0.00



**Wood Beam**

Lic. # : KW-06009431

**DESCRIPTIO BM#14**

Load Combination	Segment Length	Span #	Max Stress Ratios								Moment Values			Shear Values			
			M	V	C <sub>d</sub>	C <sub>F/V</sub>	C <sub>i</sub>	C <sub>r</sub>	C <sub>m</sub>	C <sub>t</sub>	C <sub>L</sub>	M	fb	F <sup>b</sup>	V	f <sub>v</sub>	F <sup>v</sup>
	Length = 15.50 ft	1	0.075	0.066	1.15	1.000	1.00	1.00	1.00	1.00	1.00	1.71	249.95	3335.00	0.61	21.90	333.50
	Length = 5.0 ft	2	0.075	0.066	1.15	1.000	1.00	1.00	1.00	1.00	1.71	249.95	3335.00	0.45	21.90	333.50	
+D+0.750Lr+0.750L+H						1.000	1.00	1.00	1.00	1.00			0.00	0.00	0.00	0.00	
	Length = 15.50 ft	1	0.182	0.160	1.25	1.000	1.00	1.00	1.00	1.00	4.53	660.79	3625.00	1.60	57.90	362.50	
	Length = 5.0 ft	2	0.182	0.160	1.25	1.000	1.00	1.00	1.00	1.00	4.53	660.79	3625.00	1.20	57.90	362.50	
+D+0.750L+0.750S+H						1.000	1.00	1.00	1.00	1.00			0.00	0.00	0.00	0.00	
	Length = 15.50 ft	1	0.198	0.174	1.15	1.000	1.00	1.00	1.00	1.00	4.53	660.79	3335.00	1.60	57.90	333.50	
	Length = 5.0 ft	2	0.198	0.174	1.15	1.000	1.00	1.00	1.00	1.00	4.53	660.79	3335.00	1.20	57.90	333.50	
+D+0.60W+H						1.000	1.00	1.00	1.00	1.00			0.00	0.00	0.00	0.00	
	Length = 15.50 ft	1	0.054	0.047	1.60	1.000	1.00	1.00	1.00	1.00	1.71	249.95	4640.00	0.61	21.90	464.00	
	Length = 5.0 ft	2	0.054	0.047	1.60	1.000	1.00	1.00	1.00	1.00	1.71	249.95	4640.00	0.45	21.90	464.00	
+D+0.750Lr+0.750L+0.450W-						1.000	1.00	1.00	1.00	1.00			0.00	0.00	0.00	0.00	
	Length = 15.50 ft	1	0.142	0.125	1.60	1.000	1.00	1.00	1.00	1.00	4.53	660.79	4640.00	1.60	57.90	464.00	
	Length = 5.0 ft	2	0.142	0.125	1.60	1.000	1.00	1.00	1.00	1.00	4.53	660.79	4640.00	1.20	57.90	464.00	
+D+0.750L+0.750S+0.450W+						1.000	1.00	1.00	1.00	1.00			0.00	0.00	0.00	0.00	
	Length = 15.50 ft	1	0.142	0.125	1.60	1.000	1.00	1.00	1.00	1.00	4.53	660.79	4640.00	1.60	57.90	464.00	
	Length = 5.0 ft	2	0.142	0.125	1.60	1.000	1.00	1.00	1.00	1.00	4.53	660.79	4640.00	1.20	57.90	464.00	
+0.60D+0.60W+0.60H						1.000	1.00	1.00	1.00	1.00			0.00	0.00	0.00	0.00	
	Length = 15.50 ft	1	0.032	0.028	1.60	1.000	1.00	1.00	1.00	1.00	1.03	149.97	4640.00	0.36	13.14	464.00	
	Length = 5.0 ft	2	0.032	0.028	1.60	1.000	1.00	1.00	1.00	1.00	1.03	149.97	4640.00	0.27	13.14	464.00	
+D+0.70E+0.60H						1.000	1.00	1.00	1.00	1.00			0.00	0.00	0.00	0.00	
	Length = 15.50 ft	1	0.054	0.047	1.60	1.000	1.00	1.00	1.00	1.00	1.71	249.95	4640.00	0.61	21.90	464.00	
	Length = 5.0 ft	2	0.054	0.047	1.60	1.000	1.00	1.00	1.00	1.00	1.71	249.95	4640.00	0.45	21.90	464.00	
+D+0.750L+0.750S+0.5250E-						1.000	1.00	1.00	1.00	1.00			0.00	0.00	0.00	0.00	
	Length = 15.50 ft	1	0.142	0.125	1.60	1.000	1.00	1.00	1.00	1.00	4.53	660.79	4640.00	1.60	57.90	464.00	
	Length = 5.0 ft	2	0.142	0.125	1.60	1.000	1.00	1.00	1.00	1.00	4.53	660.79	4640.00	1.20	57.90	464.00	
+0.60D+0.70E+H						1.000	1.00	1.00	1.00	1.00			0.00	0.00	0.00	0.00	
	Length = 15.50 ft	1	0.032	0.028	1.60	1.000	1.00	1.00	1.00	1.00	1.03	149.97	4640.00	0.36	13.14	464.00	
	Length = 5.0 ft	2	0.032	0.028	1.60	1.000	1.00	1.00	1.00	1.00	1.03	149.97	4640.00	0.27	13.14	464.00	

**Overall Maximum Deflections**

Load Combination	Span	Max. "-" Defl	Location in Span	Load Combination	Max. "+" Defl	Location in Span
+D+L+H	1	0.1688	7.014		0.0000	0.000
	2	0.0000	7.014	+D+L+H	-0.0125	2.011

**Vertical Reactions**

Load Combination	Support notation : Far left is #'			Values in KIPS
	Support 1	Support 2	Support 3	
Overall MAXimum	1.453	3.835	-0.511	
Overall MINimum	0.998	2.633	-0.160	
+D+H	0.455	1.202	-0.160	
+D+L+H	1.453	3.835	-0.511	
+D+Lr+H	0.455	1.202	-0.160	
+D+S+H	0.455	1.202	-0.160	
+D+0.750Lr+0.750L+H	1.204	3.177	-0.423	
+D+0.750L+0.750S+H	1.204	3.177	-0.423	
+D+0.60W+H	0.455	1.202	-0.160	
+D+0.750Lr+0.750L+0.450W+H	1.204	3.177	-0.423	
+D+0.750L+0.750S+0.450W+H	1.204	3.177	-0.423	
+0.60D+0.60W+0.60H	0.273	0.721	-0.096	
+D+0.70E+0.60H	0.455	1.202	-0.160	
+D+0.750L+0.750S+0.5250E+H	1.204	3.177	-0.423	
+0.60D+0.70E+H	0.273	0.721	-0.096	
D Only	0.455	1.202	-0.160	
Lr Only				
L Only	0.998	2.633	-0.351	
S Only				
W Only				
E Only				
H Only				

**Wood Beam**

Lic. # : KW-06009431

**DESCRIPTIO BM#15**

**CODE REFERENCES**

Calculations per NDS 2015, IBC 2015, CBC 2016, ASCE 7-10  
 Load Combination Set : ASCE 7-16

**Material Properties**

Analysis Method	Allowable Stress Design	Fb +	2,900.0 psi	E : Modulus of Elasticity	
Load Combination	ASCE 7-16	Fb -	2,900.0 psi	Ebend- xx	2,000.0ksi
Wood Species	Trus Joist	Fc - Prll	2,900.0 psi	Eminbend - x	1,016.54ksi
Wood Grade	Parallam PSL 2.0E	Fc - Perp	625.0 psi		
		Fv	290.0 psi		
		Ft	2,025.0 psi	Density	45.070pcf
Beam Bracing	Beam is Fully Braced against lateral-torsional buckling				

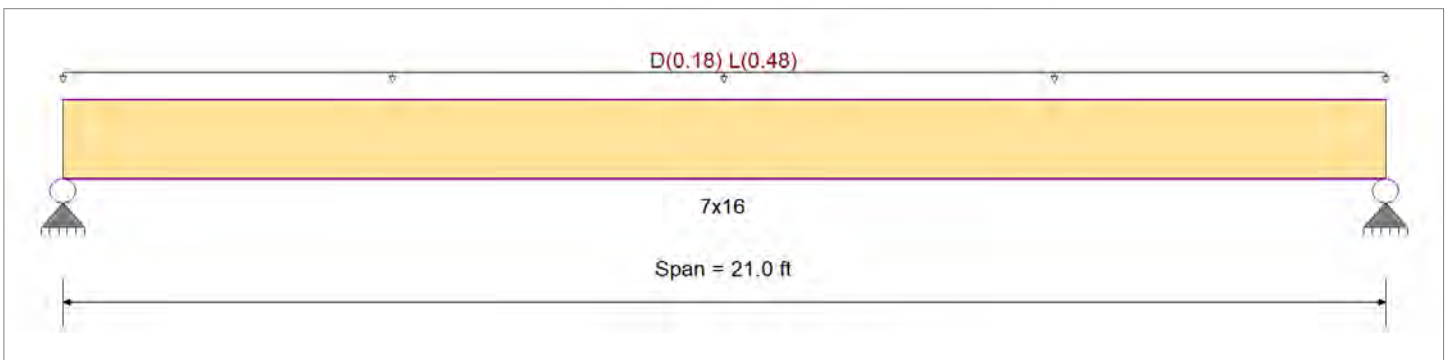

**Applied Loads**

Service loads entered. Load Factors will be applied for calculations.

Beam self weight calculated and added to loads

Uniform Load : D = 0.0150, L = 0.040 ksf, Tributary Width = 12.0 ft, (FLOOR)

**DESIGN SUMMARY**

**Design OK**

Maximum Bending Stress Ratio	=	<b>0.548</b>	1	Maximum Shear Stress Ratio	=	<b>0.295</b>	: 1
Section used for this span	=	<b>7x16</b>		Section used for this span	=	<b>7x16</b>	
	=	1,539.44	psi		=	85.61	psi
	=	2,808.86	psi		=	290.00	psi
Load Combination	=	<b>+D+L+H</b>		Load Combination	=	<b>+D+L+H</b>	
Location of maximum on span	=	<b>10.500</b>	ft	Location of maximum on span	=	<b>0.000</b>	ft
Span # where maximum occurs	=	<b>Span # 1</b>		Span # where maximum occurs	=	<b>Span # 1</b>	
<b>Maximum Deflection</b>							
Max Downward Transient Deflection		<b>0.442</b>	in	Ratio =	<b>570</b>	>=360	
Max Upward Transient Deflection		<b>0.000</b>	in	Ratio =	<b>0</b>	<360	
Max Downward Total Deflection		<b>0.640</b>	in	Ratio =	<b>393</b>	>=240	
Max Upward Total Deflection		<b>0.000</b>	in	Ratio =	<b>0</b>	<240	

**Maximum Forces & Stresses for Load Combinations**

Load Combination	Segment Length	Span #	Max Stress Ratios									Moment Values			Shear Values								
			M	V	C <sub>d</sub>	C <sub>F/V</sub>	C <sub>i</sub>	C <sub>r</sub>	C <sub>m</sub>	C <sub>t</sub>	C <sub>L</sub>	M	fb	F'b	V	fv	F'v						
+D+H	Length = 21.0 ft	1	0.188	0.101	0.90	0.969	1.00	1.00	1.00	1.00	1.00	1.00	1.00	11.85	476.31	2527.97	0.00	0.00	0.00	1.98	26.49	261.00	
+D+L+H	Length = 21.0 ft	1	0.548	0.295	1.00	0.969	1.00	1.00	1.00	1.00	1.00	1.00	1.00	38.31	1,539.44	2808.86	0.00	0.00	0.00	0.00	0.00	0.00	290.00
+D+Lr+H	Length = 21.0 ft	1	0.136	0.073	1.25	0.969	1.00	1.00	1.00	1.00	1.00	1.00	1.00	11.85	476.31	3511.07	0.00	0.00	0.00	1.98	26.49	362.50	
+D+S+H	Length = 21.0 ft	1	0.147	0.079	1.15	0.969	1.00	1.00	1.00	1.00	1.00	1.00	1.00	11.85	476.31	3230.19	0.00	0.00	0.00	1.98	26.49	333.50	
+D+0.750Lr+0.750L+H	Length = 21.0 ft	1	0.363	0.195	1.25	0.969	1.00	1.00	1.00	1.00	1.00	1.00	1.00	31.70	1,273.66	3511.07	0.00	0.00	0.00	5.29	70.83	362.50	
+D+0.750L+0.750S+H	Length = 21.0 ft	1	0.394	0.212	1.15	0.969	1.00	1.00	1.00	1.00	1.00	1.00	1.00	31.70	1,273.66	3230.19	0.00	0.00	0.00	5.29	70.83	333.50	
+D+0.60W+H						0.969	1.00	1.00	1.00	1.00	1.00	1.00				0.00			0.00	0.00	0.00		

**Wood Beam**

Lic. # : KW-06009431

**DESCRIPTIO BM#15**

Load Combination	Segment Length	Span #	Max Stress Ratios									Moment Values			Shear Values		
			M	V	C <sub>d</sub>	C <sub>F/V</sub>	C <sub>i</sub>	C <sub>r</sub>	C <sub>m</sub>	C <sub>t</sub>	C <sub>L</sub>	M	fb	F'b	V	fv	F'v
Length = 21.0 ft	1	0.106	0.057	1.60	0.969	1.00	1.00	1.00	1.00	1.00	11.85	476.31	4494.17	1.98	26.49	464.00	
+D+0.750Lr+0.750L+0.450W-					0.969	1.00	1.00	1.00	1.00	1.00			0.00	0.00	0.00	0.00	
Length = 21.0 ft	1	0.283	0.153	1.60	0.969	1.00	1.00	1.00	1.00	1.00	31.70	1,273.66	4494.17	5.29	70.83	464.00	
+D+0.750L+0.750S+0.450W+					0.969	1.00	1.00	1.00	1.00	1.00			0.00	0.00	0.00	0.00	
Length = 21.0 ft	1	0.283	0.153	1.60	0.969	1.00	1.00	1.00	1.00	1.00	31.70	1,273.66	4494.17	5.29	70.83	464.00	
+0.60D+0.60W+0.60H					0.969	1.00	1.00	1.00	1.00	1.00			0.00	0.00	0.00	0.00	
Length = 21.0 ft	1	0.064	0.034	1.60	0.969	1.00	1.00	1.00	1.00	1.00	7.11	285.79	4494.17	1.19	15.89	464.00	
+D+0.70E+0.60H					0.969	1.00	1.00	1.00	1.00	1.00			0.00	0.00	0.00	0.00	
Length = 21.0 ft	1	0.106	0.057	1.60	0.969	1.00	1.00	1.00	1.00	1.00	11.85	476.31	4494.17	1.98	26.49	464.00	
+D+0.750L+0.750S+0.5250E-					0.969	1.00	1.00	1.00	1.00	1.00			0.00	0.00	0.00	0.00	
Length = 21.0 ft	1	0.283	0.153	1.60	0.969	1.00	1.00	1.00	1.00	1.00	31.70	1,273.66	4494.17	5.29	70.83	464.00	
+0.60D+0.70E+H					0.969	1.00	1.00	1.00	1.00	1.00			0.00	0.00	0.00	0.00	
Length = 21.0 ft	1	0.064	0.034	1.60	0.969	1.00	1.00	1.00	1.00	1.00	7.11	285.79	4494.17	1.19	15.89	464.00	

**Overall Maximum Deflections**

Load Combination	Span	Max. "-" Defl	Location in Span	Load Combination	Max. "+" Defl	Location in Span
+D+L+H	1	0.6402	10.577		0.0000	0.000

**Vertical Reactions**

Support notation : Far left is #'

Values in KIPS

Load Combination	Support 1	Support 2
Overall MAXimum	7.298	7.298
Overall MINimum	5.040	5.040
+D+H	2.258	2.258
+D+L+H	7.298	7.298
+D+Lr+H	2.258	2.258
+D+S+H	2.258	2.258
+D+0.750Lr+0.750L+H	6.038	6.038
+D+0.750L+0.750S+H	6.038	6.038
+D+0.60W+H	2.258	2.258
+D+0.750Lr+0.750L+0.450W+H	6.038	6.038
+D+0.750L+0.750S+0.450W+H	6.038	6.038
+0.60D+0.60W+0.60H	1.355	1.355
+D+0.70E+0.60H	2.258	2.258
+D+0.750L+0.750S+0.5250E+H	6.038	6.038
+0.60D+0.70E+H	1.355	1.355
D Only	2.258	2.258
Lr Only		
L Only	5.040	5.040
S Only		
W Only		
E Only		
H Only		

## Wood Beam

Lic. # : KW-06009431

### DESCRIPTIO BM#16

### CODE REFERENCES

Calculations per NDS 2015, IBC 2015, CBC 2016, ASCE 7-10  
Load Combination Set : ASCE 7-16

### Material Properties

Analysis Method	Allowable Stress Design	Fb +	2,900.0 psi	E : Modulus of Elasticity	
Load Combination	ASCE 7-16	Fb -	2,900.0 psi	Ebend- xx	2,000.0ksi
Wood Species	Trus Joist	Fc - Prll	2,900.0 psi	Eminbend - x	1,016.54ksi
Wood Grade	Parallam PSL 2.0E	Fc - Perp	625.0 psi		
		Fv	290.0 psi		
		Ft	2,025.0 psi	Density	45.070pcf
Beam Bracing	Beam is Fully Braced against lateral-torsional buckling				

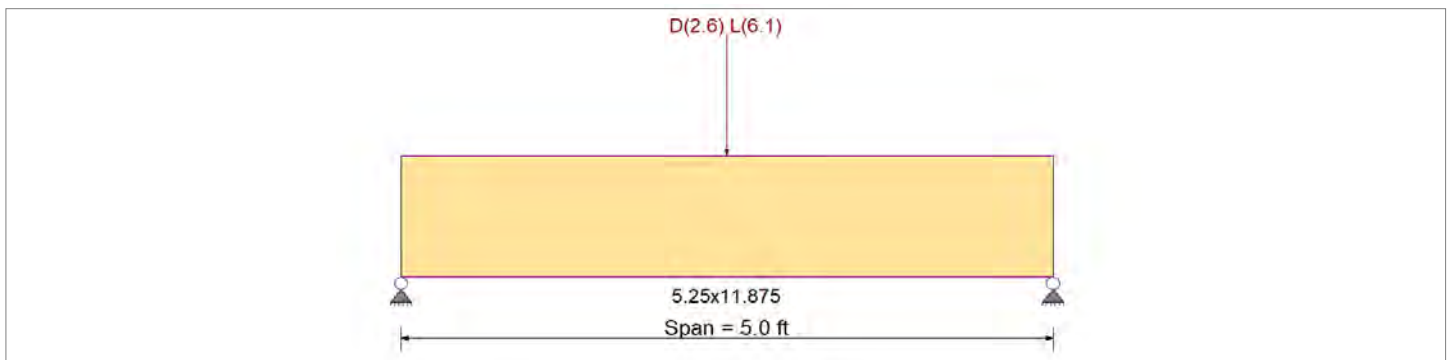

### Applied Loads

Service loads entered. Load Factors will be applied for calculations.

Beam self weight calculated and added to loads  
Point Load : D = 2.60, L = 6.10 k @ 2.50 ft, (BM37)

### DESIGN SUMMARY

**Design OK**

Maximum Bending Stress Ratio	=	<b>0.367</b> : 1	Maximum Shear Stress Ratio	=	<b>0.363</b> : 1
Section used for this span	=	<b>5.25x11.875</b>	Section used for this span	=	<b>5.25x11.875</b>
	=	1,063.56psi		=	105.37 psi
	=	2,900.00psi		=	290.00 psi
Load Combination	=	<b>+D+L+H</b>	Load Combination	=	<b>+D+L+H</b>
Location of maximum on span	=	<b>2.500ft</b>	Location of maximum on span	=	<b>4.015 ft</b>
Span # where maximum occurs	=	<b>Span # 1</b>	Span # where maximum occurs	=	<b>Span # 1</b>
<b>Maximum Deflection</b>					
Max Downward Transient Deflection		<b>0.019</b> in	Ratio =	<b>3185</b> >=360	
Max Upward Transient Deflection		<b>0.000</b> in	Ratio =	<b>0</b> <360	
Max Downward Total Deflection		<b>0.027</b> in	Ratio =	<b>2217</b> >=240	
Max Upward Total Deflection		<b>0.000</b> in	Ratio =	<b>0</b> <240	

### Maximum Forces & Stresses for Load Combinations

Load Combination	Segment Length	Span #	Max Stress Ratios									Moment Values			Shear Values								
			M	V	C <sub>d</sub>	C <sub>F/V</sub>	C <sub>i</sub>	C <sub>r</sub>	C <sub>m</sub>	C <sub>t</sub>	C <sub>L</sub>	M	fb	F'b	V	fv	F'v						
+D+H	Length = 5.0 ft	1	0.123	0.123	0.90	1.000	1.00	1.00	1.00	1.00	1.00	1.00	1.00	1.00	3.31	322.00	2610.00	0.00	0.00	0.00	1.33	31.99	261.00
+D+L+H	Length = 5.0 ft	1	0.367	0.363	1.00	1.000	1.00	1.00	1.00	1.00	1.00	1.00	1.00	1.00	10.94	1,063.56	2900.00	0.00	0.00	0.00	4.38	105.37	290.00
+D+Lr+H	Length = 5.0 ft	1	0.089	0.088	1.25	1.000	1.00	1.00	1.00	1.00	1.00	1.00	1.00	1.00	3.31	322.00	3625.00	0.00	0.00	0.00	1.33	31.99	362.50
+D+S+H	Length = 5.0 ft	1	0.097	0.096	1.15	1.000	1.00	1.00	1.00	1.00	1.00	1.00	1.00	1.00	3.31	322.00	3335.00	0.00	0.00	0.00	1.33	31.99	333.50
+D+0.750Lr+0.750L+H	Length = 5.0 ft	1	0.242	0.240	1.25	1.000	1.00	1.00	1.00	1.00	1.00	1.00	1.00	1.00	9.03	878.17	3625.00	0.00	0.00	0.00	3.62	87.03	362.50
+D+0.750L+0.750S+H	Length = 5.0 ft	1	0.263	0.261	1.15	1.000	1.00	1.00	1.00	1.00	1.00	1.00	1.00	1.00	9.03	878.17	3335.00	0.00	0.00	0.00	3.62	87.03	333.50
+D+0.60W+H					1.000	1.00	1.00	1.00	1.00	1.00	1.00	1.00	1.00	1.00			0.00	0.00	0.00	0.00	0.00	0.00	0.00

**Wood Beam**

Lic. # : KW-06009431

**DESCRIPTIO BM#16**

Load Combination	Segment Length	Span #	Max Stress Ratios									Moment Values			Shear Values		
			M	V	C <sub>d</sub>	C <sub>F/V</sub>	C <sub>i</sub>	C <sub>r</sub>	C <sub>m</sub>	C <sub>t</sub>	C <sub>L</sub>	M	fb	F'b	V	fv	F'v
Length = 5.0 ft	1	0.069	0.069	1.60	1.000	1.00	1.00	1.00	1.00	1.00	1.00	3.31	322.00	4640.00	1.33	31.99	464.00
+D+0.750Lr+0.750L+0.450W-					1.000	1.00	1.00	1.00	1.00	1.00	1.00			0.00	0.00	0.00	0.00
Length = 5.0 ft	1	0.189	0.188	1.60	1.000	1.00	1.00	1.00	1.00	1.00	1.00	9.03	878.17	4640.00	3.62	87.03	464.00
+D+0.750L+0.750S+0.450W+					1.000	1.00	1.00	1.00	1.00	1.00	1.00			0.00	0.00	0.00	0.00
Length = 5.0 ft	1	0.189	0.188	1.60	1.000	1.00	1.00	1.00	1.00	1.00	1.00	9.03	878.17	4640.00	3.62	87.03	464.00
+0.60D+0.60W+0.60H					1.000	1.00	1.00	1.00	1.00	1.00	1.00			0.00	0.00	0.00	0.00
Length = 5.0 ft	1	0.042	0.041	1.60	1.000	1.00	1.00	1.00	1.00	1.00	1.00	1.99	193.20	4640.00	0.80	19.19	464.00
+D+0.70E+0.60H					1.000	1.00	1.00	1.00	1.00	1.00	1.00			0.00	0.00	0.00	0.00
Length = 5.0 ft	1	0.069	0.069	1.60	1.000	1.00	1.00	1.00	1.00	1.00	1.00	3.31	322.00	4640.00	1.33	31.99	464.00
+D+0.750L+0.750S+0.5250E-					1.000	1.00	1.00	1.00	1.00	1.00	1.00			0.00	0.00	0.00	0.00
Length = 5.0 ft	1	0.189	0.188	1.60	1.000	1.00	1.00	1.00	1.00	1.00	1.00	9.03	878.17	4640.00	3.62	87.03	464.00
+0.60D+0.70E+H					1.000	1.00	1.00	1.00	1.00	1.00	1.00			0.00	0.00	0.00	0.00
Length = 5.0 ft	1	0.042	0.041	1.60	1.000	1.00	1.00	1.00	1.00	1.00	1.00	1.99	193.20	4640.00	0.80	19.19	464.00

**Overall Maximum Deflections**

Load Combination	Span	Max. "-" Defl	Location in Span	Load Combination	Max. "+" Defl	Location in Span
+D+L+H	1	0.0271	2.518		0.0000	0.000

**Vertical Reactions**

Support notation : Far left is #'

Values in KIPS

Load Combination	Support 1	Support 2
Overall MAXimum	4.399	4.399
Overall MINimum	3.050	3.050
+D+H	1.349	1.349
+D+L+H	4.399	4.399
+D+Lr+H	1.349	1.349
+D+S+H	1.349	1.349
+D+0.750Lr+0.750L+H	3.636	3.636
+D+0.750L+0.750S+H	3.636	3.636
+D+0.60W+H	1.349	1.349
+D+0.750Lr+0.750L+0.450W+H	3.636	3.636
+D+0.750L+0.750S+0.450W+H	3.636	3.636
+0.60D+0.60W+0.60H	0.809	0.809
+D+0.70E+0.60H	1.349	1.349
+D+0.750L+0.750S+0.5250E+H	3.636	3.636
+0.60D+0.70E+H	0.809	0.809
D Only	1.349	1.349
Lr Only		
L Only	3.050	3.050
S Only		
W Only		
E Only		
H Only		



**Wood Column**

Lic. # : KW-06009431

**DESCRIPTIO COL#1**

**Code References**

Calculations per NDS 2015, IBC 2015, CBC 2016, ASCE 7-10  
 Load Combinations Used : ASCE 7-16

**General Information**

Analysis Metho	Allowable Stress Design			Wood Section Name	<b>7x7</b>	
End Fixities	Top & Bottom Pinned			Wood Grading/Manuf.	Trus Joist	
Overall Column Heigh	10 ft			Wood Member Type	Parallam PSL	
<i>( Used for non-slender calculations )</i>						
Wood Specie	Trus Joist			Exact Width	<b>7.0</b> in	
Wood Grade	Parallam PSL 2.0E			Exact Depth	<b>7.0</b> in	
Fb +	2900 psi	Fv	290 psi	Area	49.0 in^2	
Fb -	2900 psi	Ft	2025 psi	Ix	200.083 in^4	
Fc - Prll	2900 psi	Density	45.07 pcf	Iy	200.083 in^4	
Fc - Perp	625 psi					
E : Modulus of Elasticity . . .	x-x Bending	y-y Bending	Axial	Allow Stress Modification Factors		
	Basic	2000	2000	2000 ksi	Cf or Cv for Bending	1.0
	Minimum	1016.535	1016.535		Cf or Cv for Compression	1.0
					Cf or Cv for Tension	1.0
					Cm : Wet Use Factor	1.0
					Ct : Temperature Fact	1.0
					Cfu : Flat Use Factor	1.0
					Kf : Built-up columns	1.0 <i>NDS 15.3.2</i>
					Use Cr : Repetitive	No
Brace condition for deflection (buckling) along columns :						
X-X (width) axis Unbraced Length for buckling ABOUT Y-Y Axis = 1C						
Y-Y (depth) axis Unbraced Length for buckling ABOUT X-X Axis = 1C						

**Applied Loads**

Service loads entered. Load Factors will be applied for calculations.

Column self weight included : 153.363 lbs \* Dead Load Factor

AXIAL LOADS . . .

BM#8: Axial Load at 10.0 ft, D = 9.10, L = 5.60, S = 9.30 k

**DESIGN SUMMARY**

**Bending & Shear Check Results**

**PASS** Max. Axial+Bending Stress Ratio = **0.180 : 1**

Load Combination **+D+0.750L+0.750S+H**

Governing NDS Formula **Comp Only, fc/Fc'**

Location of max.above base **0.0 ft**

At maximum location values are .

Applied Axial **20.428 k**

Applied Mx **0.0 k-ft**

Applied My **0.0 k-ft**

Fc : Allowable **2,316.48 psi**

**Maximum SERVICE Lateral Load Reactions . .**

Top along Y-Y	0.0 k	Bottom along Y-Y	0.0 k
Top along X-X	0.0 k	Bottom along X-X	0.0 k

**Maximum SERVICE Load Lateral Deflections . . .**

Along Y-Y	0.0 in	at	0.0 ft	above base
for load combination : n/a				
Along X-X	0.0 in	at	0.0 ft	above base
for load combination : n/a				

**PASS** Maximum Shear Stress Ratio = **0.0 : 1**

Load Combination **+0.60D+0.70E+H**

Location of max.above base **10.0 ft**

Applied Design Shear **0.0 psi**

Allowable Shear **464.0 psi**

**Other Factors used to calculate allowable stresses . . .**

Bending    Compression    Tension

**Load Combination Results**

Load Combination	C <sub>D</sub>	C <sub>P</sub>	Maximum Axial + Bending Stress Ratios			Maximum Shear Ratios		
			Stress Ratio	Status	Location	Stress Ratio	Status	Location
+D+H	0.900	0.791	0.09151	PASS	0.0 ft	0.0	PASS	10.0 ft
+D+L+H	1.000	0.752	0.1390	PASS	0.0 ft	0.0	PASS	10.0 ft
+D+Lr+H	1.250	0.658	0.07919	PASS	0.0 ft	0.0	PASS	10.0 ft
+D+S+H	1.150	0.695	0.1635	PASS	0.0 ft	0.0	PASS	10.0 ft
+D+0.750Lr+0.750L+H	1.250	0.658	0.1151	PASS	0.0 ft	0.0	PASS	10.0 ft
+D+0.750L+0.750S+H	1.150	0.695	0.180	PASS	0.0 ft	0.0	PASS	10.0 ft
+D+0.60W+H	1.600	0.547	0.07443	PASS	0.0 ft	0.0	PASS	10.0 ft
+D+0.750Lr+0.750L+0.450W+H	1.600	0.547	0.1082	PASS	0.0 ft	0.0	PASS	10.0 ft
+D+0.750L+0.750S+0.450W+H	1.600	0.547	0.1643	PASS	0.0 ft	0.0	PASS	10.0 ft
+0.60D+0.60W+0.60H	1.600	0.547	0.04466	PASS	0.0 ft	0.0	PASS	10.0 ft
+D+0.70E+0.60H	1.600	0.547	0.07443	PASS	0.0 ft	0.0	PASS	10.0 ft
+D+0.750L+0.750S+0.5250E+H	1.600	0.547	0.1643	PASS	0.0 ft	0.0	PASS	10.0 ft

**Wood Column**

Lic. # : KW-06009431

**DESCRIPTIO COL#1**

**Load Combination Results**

Load Combination	C <sub>D</sub>	C <sub>P</sub>	Maximum Axial + Bending Stress Ratios			Maximum Shear Ratios		
			Stress Ratio	Status	Location	Stress Ratio	Status	Location
+0.60D+0.70E+H	1.600	0.547	0.04466	PASS	0.0 ft	0.0	PASS	10.0 ft

**Maximum Reactions**

Note: Only non-zero reactions are listed.

Load Combination	X-X Axis Reaction		k	Y-Y Axis Reaction		Axial Reaction	My - End Moments		k-ft Mx - End Moments	
	@ Base	@ Top		@ Base	@ Top		@ Base	@ Top	@ Base	@ Top
+D+H						9.253				
+D+L+H						14.853				
+D+Lr+H						9.253				
+D+S+H						18.553				
+D+0.750Lr+0.750L+H						13.453				
+D+0.750L+0.750S+H						20.428				
+D+0.60W+H						9.253				
+D+0.750Lr+0.750L+0.450W+H						13.453				
+D+0.750L+0.750S+0.450W+H						20.428				
+0.60D+0.60W+0.60H						5.552				
+D+0.70E+0.60H						9.253				
+D+0.750L+0.750S+0.5250E+H						20.428				
+0.60D+0.70E+H						5.552				
D Only						9.253				
Lr Only										
L Only						5.600				
S Only						9.300				
W Only										
E Only										
H Only										

**Maximum Deflections for Load Combinations**

Load Combination	Max. X-X Deflection		Distance	Max. Y-Y Deflection		Distance
+D+H	0.000	0.000		0.000	0.000	
+D+L+H	0.000	0.000		0.000	0.000	
+D+Lr+H	0.000	0.000		0.000	0.000	
+D+S+H	0.000	0.000		0.000	0.000	
+D+0.750Lr+0.750L+H	0.000	0.000		0.000	0.000	
+D+0.750L+0.750S+H	0.000	0.000		0.000	0.000	
+D+0.60W+H	0.000	0.000		0.000	0.000	
+D+0.750Lr+0.750L+0.450W+H	0.000	0.000		0.000	0.000	
+D+0.750L+0.750S+0.450W+H	0.000	0.000		0.000	0.000	
+0.60D+0.60W+0.60H	0.000	0.000		0.000	0.000	
+D+0.70E+0.60H	0.000	0.000		0.000	0.000	
+D+0.750L+0.750S+0.5250E+H	0.000	0.000		0.000	0.000	
+0.60D+0.70E+H	0.000	0.000		0.000	0.000	
D Only	0.000	0.000		0.000	0.000	
Lr Only	0.000	0.000		0.000	0.000	
L Only	0.000	0.000		0.000	0.000	
S Only	0.000	0.000		0.000	0.000	
W Only	0.000	0.000		0.000	0.000	
E Only	0.000	0.000		0.000	0.000	
H Only	0.000	0.000		0.000	0.000	

## Wood Column

Lic. # : KW-06009431

DESCRIPTIO COL#1

### Sketches

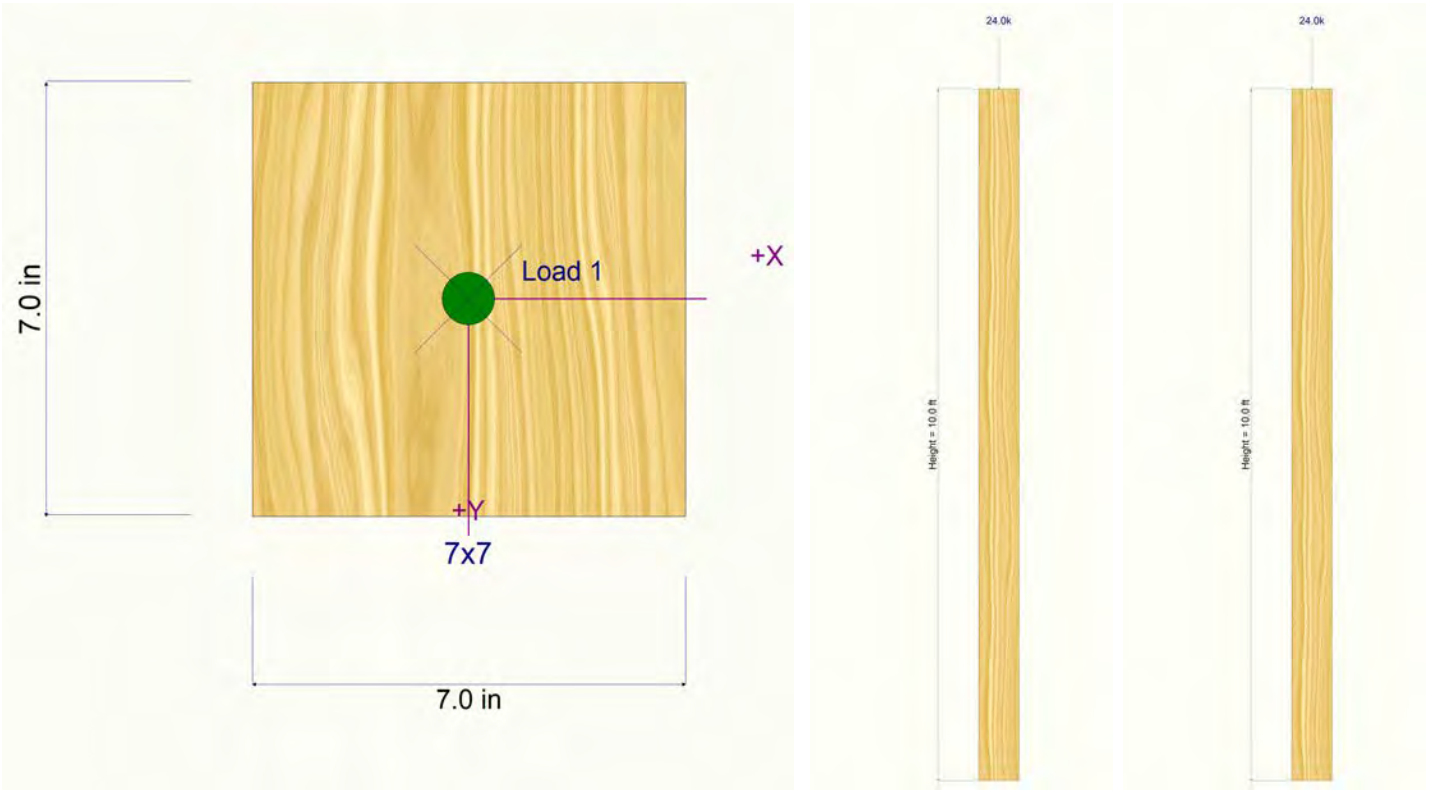

## Wood Column

Lic. # : KW-06009431

### DESCRIPTIO COL#2

#### Code References

Calculations per NDS 2015, IBC 2015, CBC 2016, ASCE 7-10  
Load Combinations Used : ASCE 7-16

#### General Information

Analysis Metho	Allowable Stress Design			Wood Section Name	<b>3.5x9.5</b>	
End Fixities	Top & Bottom Pinned			Wood Grading/Manuf.	Trus Joist	
Overall Column Heigh	11 ft			Wood Member Type	Parallam PSL	
<i>( Used for non-slender calculations )</i>						
Wood Specie	Trus Joist			Exact Width	<b>3.50</b> in	
Wood Grade	Parallam PSL 2.0E			Exact Depth	<b>9.50</b> in	
Fb +	2,900.0 psi	Fv	290.0 psi	Area	33.250 in <sup>2</sup>	
Fb -	2,900.0 psi	Ft	2,025.0 psi	Ix	250.068 in <sup>4</sup>	
Fc - Prll	2,900.0 psi	Density	45.070 pcf	Iy	33.943 in <sup>4</sup>	
Fc - Perp	625.0 psi					
E : Modulus of Elasticity . . .	x-x Bending	y-y Bending	Axial	Allow Stress Modification Factors		
	Basic	2,000.0	2,000.0	2,000.0 ksi	Cf or Cv for Bending	1.0
	Minimum	1,016.54	1,016.54		Cf or Cv for Compression	1.0
					Cf or Cv for Tension	1.0
					Cm : Wet Use Factor	1.0
					Ct : Temperature Fact	1.0
					Cfu : Flat Use Factor	1.0
					Kf : Built-up columns	1.0 <i>NDS 15.3.2</i>
					Use Cr : Repetitive	No
Brace condition for deflection (buckling) along columns :						
X-X (width) axis Unbraced Length for buckling ABOUT Y-Y Axis = 11						
Y-Y (depth) axis Unbraced Length for buckling ABOUT X-X Axis = 11						

#### Applied Loads

Service loads entered. Load Factors will be applied for calculations.

Column self weight included : 114.475 lbs \* Dead Load Factor

AXIAL LOADS . . .

BM#10&11: Axial Load at 11.0 ft, D = 5.470, L = 2.320, S = 5.650 k

#### DESIGN SUMMARY

##### Bending & Shear Check Results

**PASS** Max. Axial+Bending Stress Ratio = **0.6043 : 1**  
 Load Combination **+D+0.750L+0.750S+H**  
 Governing NDS Formula **Comp Only, fc/Fc'**  
 Location of max.above base **0.0 ft**  
 At maximum location values are .  
 Applied Axial **11.562 k**  
 Applied Mx **0.0 k-ft**  
 Applied My **0.0 k-ft**  
 Fc : Allowable **575.47 psi**

**Maximum SERVICE Lateral Load Reactions . .**  
 Top along Y-Y **0.0 k** Bottom along Y-Y **0.0 k**  
 Top along X-X **0.0 k** Bottom along X-X **0.0 k**

**Maximum SERVICE Load Lateral Deflections . . .**  
 Along Y-Y **0.0 in** at **0.0 ft** above base  
 for load combination : **n/a**  
 Along X-X **0.0 in** at **0.0 ft** above base  
 for load combination : **n/a**

**PASS** Maximum Shear Stress Ratio = **0.0 : 1**  
 Load Combination **+0.60D+0.70E+H**  
 Location of max.above base **11.0 ft**  
 Applied Design Shear **0.0 psi**  
 Allowable Shear **464.0 psi**

**Other Factors used to calculate allowable stresses . . .**  
Bending Compression Tension

#### Load Combination Results

Load Combination	C <sub>D</sub>	C <sub>P</sub>	Maximum Axial + Bending Stress Ratios			Maximum Shear Ratios		
			Stress Ratio	Status	Location	Stress Ratio	Status	Location
+D+H	0.900	0.219	0.2939	PASS	0.0 ft	0.0	PASS	11.0 ft
+D+L+H	1.000	0.198	0.4146	PASS	0.0 ft	0.0	PASS	11.0 ft
+D+Lr+H	1.250	0.159	0.2913	PASS	0.0 ft	0.0	PASS	11.0 ft
+D+S+H	1.150	0.173	0.5871	PASS	0.0 ft	0.0	PASS	11.0 ft
+D+0.750Lr+0.750L+H	1.250	0.159	0.3821	PASS	0.0 ft	0.0	PASS	11.0 ft
+D+0.750L+0.750S+H	1.150	0.173	0.6043	PASS	0.0 ft	0.0	PASS	11.0 ft
+D+0.60W+H	1.600	0.125	0.290	PASS	0.0 ft	0.0	PASS	11.0 ft
+D+0.750Lr+0.750L+0.450W+H	1.600	0.125	0.3803	PASS	0.0 ft	0.0	PASS	11.0 ft
+D+0.750L+0.750S+0.450W+H	1.600	0.125	0.6004	PASS	0.0 ft	0.0	PASS	11.0 ft
+0.60D+0.60W+0.60H	1.600	0.125	0.1740	PASS	0.0 ft	0.0	PASS	11.0 ft
+D+0.70E+0.60H	1.600	0.125	0.290	PASS	0.0 ft	0.0	PASS	11.0 ft
+D+0.750L+0.750S+0.5250E+H	1.600	0.125	0.6004	PASS	0.0 ft	0.0	PASS	11.0 ft

**Wood Column**

Lic. # : KW-06009431

**DESCRIPTIO COL#2**

**Load Combination Results**

Load Combination	C <sub>D</sub>	C <sub>P</sub>	Maximum Axial + Bending Stress Ratios			Maximum Shear Ratios		
			Stress Ratio	Status	Location	Stress Ratio	Status	Location
+0.60D+0.70E+H	1.600	0.125	0.1740	PASS	0.0 ft	0.0	PASS	11.0 ft

**Maximum Reactions**

Note: Only non-zero reactions are listed.

Load Combination	X-X Axis Reaction		k	Y-Y Axis Reaction		Axial Reaction	My - End Moments		k-ft Mx - End Moments	
	@ Base	@ Top		@ Base	@ Top		@ Base	@ Top	@ Base	@ Top
+D+H						5.584				
+D+L+H						7.904				
+D+Lr+H						5.584				
+D+S+H						11.234				
+D+0.750Lr+0.750L+H						7.324				
+D+0.750L+0.750S+H						11.562				
+D+0.60W+H						5.584				
+D+0.750Lr+0.750L+0.450W+H						7.324				
+D+0.750L+0.750S+0.450W+H						11.562				
+0.60D+0.60W+0.60H						3.351				
+D+0.70E+0.60H						5.584				
+D+0.750L+0.750S+0.5250E+H						11.562				
+0.60D+0.70E+H						3.351				
D Only						5.584				
Lr Only										
L Only						2.320				
S Only						5.650				
W Only										
E Only										
H Only										

**Maximum Deflections for Load Combinations**

Load Combination	Max. X-X Deflection		Distance	Max. Y-Y Deflection		Distance
+D+H	0.000	0.000		0.000	0.000	
+D+L+H	0.000	0.000		0.000	0.000	
+D+Lr+H	0.000	0.000		0.000	0.000	
+D+S+H	0.000	0.000		0.000	0.000	
+D+0.750Lr+0.750L+H	0.000	0.000		0.000	0.000	
+D+0.750L+0.750S+H	0.000	0.000		0.000	0.000	
+D+0.60W+H	0.000	0.000		0.000	0.000	
+D+0.750Lr+0.750L+0.450W+H	0.000	0.000		0.000	0.000	
+D+0.750L+0.750S+0.450W+H	0.000	0.000		0.000	0.000	
+0.60D+0.60W+0.60H	0.000	0.000		0.000	0.000	
+D+0.70E+0.60H	0.000	0.000		0.000	0.000	
+D+0.750L+0.750S+0.5250E+H	0.000	0.000		0.000	0.000	
+0.60D+0.70E+H	0.000	0.000		0.000	0.000	
D Only	0.000	0.000		0.000	0.000	
Lr Only	0.000	0.000		0.000	0.000	
L Only	0.000	0.000		0.000	0.000	
S Only	0.000	0.000		0.000	0.000	
W Only	0.000	0.000		0.000	0.000	
E Only	0.000	0.000		0.000	0.000	
H Only	0.000	0.000		0.000	0.000	



## Wood Column

Lic. # : KW-06009431

DESCRIPTIO COL#2

### Sketches

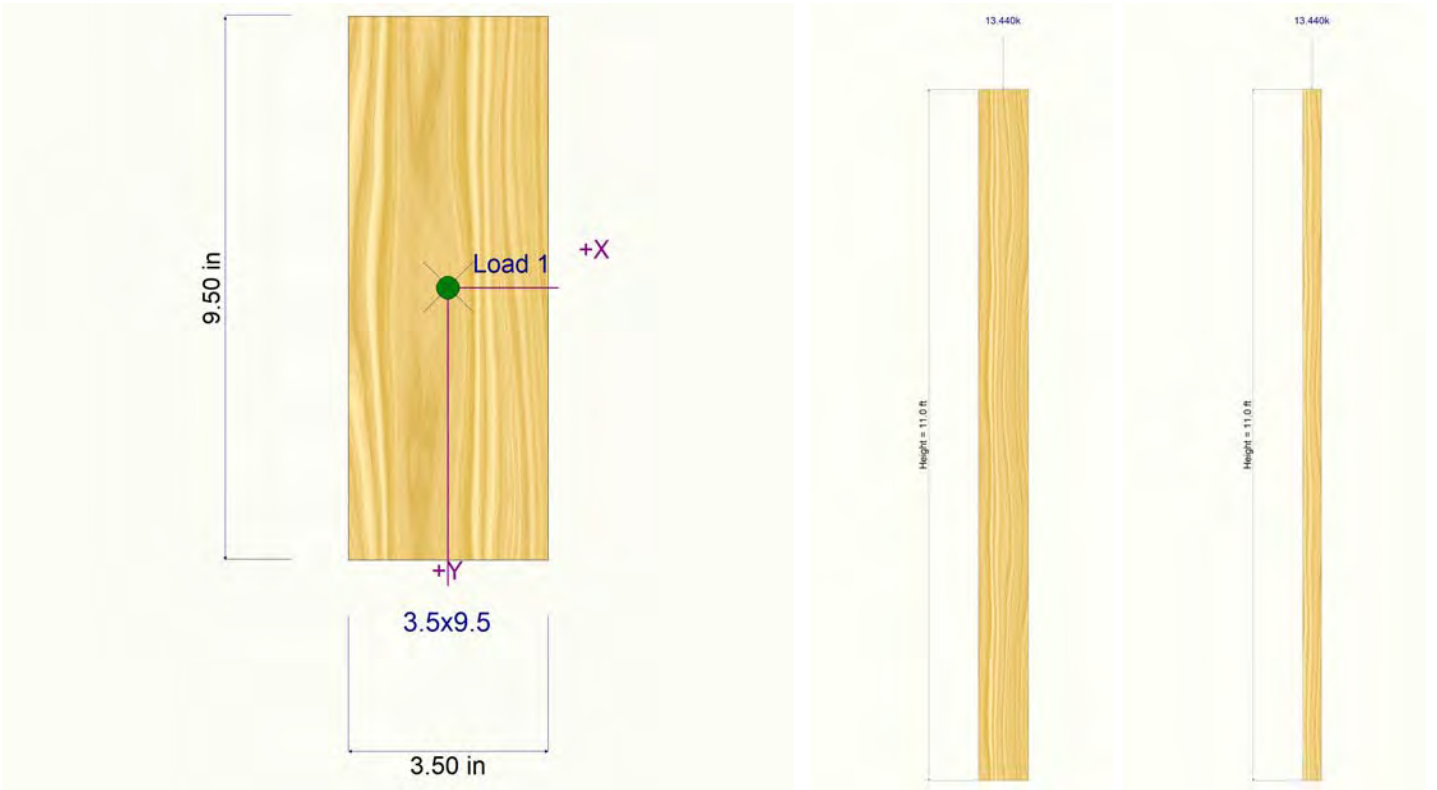

## Wood Column

Lic. # : KW-06009431

### DESCRIPTIO COL#3

#### Code References

Calculations per NDS 2015, IBC 2015, CBC 2016, ASCE 7-10  
Load Combinations Used : ASCE 7-16

#### General Information

Analysis Metho	Allowable Stress Design			Wood Section Name	5.25x5.25
End Fixities	Top & Bottom Pinned			Wood Grading/Manuf.	Trus Joist
Overall Column Heigh	11 ft			Wood Member Type	Parallam PSL
<i>( Used for non-slender calculations )</i>					
Wood Specie	Trus Joist			Exact Width	5.250 in
Wood Grade	Parallam PSL 2.0E			Exact Depth	5.250 in
Fb +	2,900.0 psi	Fv	290.0 psi	Area	27.563 in^2
Fb -	2,900.0 psi	Ft	2,025.0 psi	Ix	63.308 in^4
Fc - Prll	2,900.0 psi	Density	45.070 pcf	Iy	63.308 in^4
Fc - Perp	625.0 psi			Allow Stress Modification Factors	
E : Modulus of Elasticity . . .	x-x Bending	y-y Bending	Axial	Cf or Cv for Bending	1.0
	Basic	2,000.0	2,000.0	Cf or Cv for Compression	1.0
	Minimum	1,016.54	1,016.54	Cf or Cv for Tension	1.0
			2,000.0 ksi	Cm : Wet Use Factor	1.0
				Ct : Temperature Fact	1.0
				Cfu : Flat Use Factor	1.0
				Kf : Built-up columns	1.0 <small>NDS 15.3.2</small>
				Use Cr : Repetitive	No
Brace condition for deflection (buckling) along columns :					
X-X (width) axis Unbraced Length for buckling ABOUT Y-Y Axis = 11					
Y-Y (depth) axis Unbraced Length for buckling ABOUT X-X Axis = 11					

#### Applied Loads

Service loads entered. Load Factors will be applied for calculations.

Column self weight included : 94.895 lbs \* Dead Load Factor

AXIAL LOADS . . .

BM#8&9: Axial Load at 11.0 ft, D = 10.860, L = 3.90, S = 12.30 k

#### DESIGN SUMMARY

##### Bending & Shear Check Results

**PASS** Max. Axial+Bending Stress Ratio = **0.6764 : 1**

Load Combination	+D+S+H
Governing NDS Formula	Comp Only, $f_c/F_c'$
Location of max.above base	0.0 ft
At maximum location values are .	
Applied Axial	23.255 k
Applied Mx	0.0 k-ft
Applied My	0.0 k-ft
Fc : Allowable	1,247.29 psi

**Maximum SERVICE Lateral Load Reactions . .**

Top along Y-Y	0.0 k	Bottom along Y-Y	0.0 k
Top along X-X	0.0 k	Bottom along X-X	0.0 k

**Maximum SERVICE Load Lateral Deflections . . .**

Along Y-Y	0.0 in	at	0.0 ft	above base
for load combination : n/a				
Along X-X	0.0 in	at	0.0 ft	above base
for load combination : n/a				

**PASS** Maximum Shear Stress Ratio = **0.0 : 1**

Load Combination	+0.60D+0.70E+H
Location of max.above base	11.0 ft
Applied Design Shear	0.0 psi
Allowable Shear	464.0 psi

**Other Factors used to calculate allowable stresses . . .**

Bending	Compression	Tension
---------	-------------	---------

#### Load Combination Results

Load Combination	C <sub>D</sub>	C <sub>P</sub>	Maximum Axial + Bending Stress Ratios			Maximum Shear Ratios		
			Stress Ratio	Status	Location	Stress Ratio	Status	Location
+D+H	0.900	0.466	0.3269	PASS	0.0 ft	0.0	PASS	11.0 ft
+D+L+H	1.000	0.424	0.4378	PASS	0.0 ft	0.0	PASS	11.0 ft
+D+Lr+H	1.250	0.346	0.3166	PASS	0.0 ft	0.0	PASS	11.0 ft
+D+S+H	1.150	0.374	0.6764	PASS	0.0 ft	0.0	PASS	11.0 ft
+D+0.750Lr+0.750L+H	1.250	0.346	0.4012	PASS	0.0 ft	0.0	PASS	11.0 ft
+D+0.750L+0.750S+H	1.150	0.374	0.6721	PASS	0.0 ft	0.0	PASS	11.0 ft
+D+0.60W+H	1.600	0.274	0.3121	PASS	0.0 ft	0.0	PASS	11.0 ft
+D+0.750Lr+0.750L+0.450W+H	1.600	0.274	0.3954	PASS	0.0 ft	0.0	PASS	11.0 ft
+D+0.750L+0.750S+0.450W+H	1.600	0.274	0.6582	PASS	0.0 ft	0.0	PASS	11.0 ft
+0.60D+0.60W+0.60H	1.600	0.274	0.1872	PASS	0.0 ft	0.0	PASS	11.0 ft
+D+0.70E+0.60H	1.600	0.274	0.3121	PASS	0.0 ft	0.0	PASS	11.0 ft
+D+0.750L+0.750S+0.5250E+H	1.600	0.274	0.6582	PASS	0.0 ft	0.0	PASS	11.0 ft

**Wood Column**

Lic. # : KW-06009431

**DESCRIPTIO COL#3**

**Load Combination Results**

Load Combination	C <sub>D</sub>	C <sub>P</sub>	Maximum Axial + Bending Stress Ratios			Maximum Shear Ratios		
			Stress Ratio	Status	Location	Stress Ratio	Status	Location
+0.60D+0.70E+H	1.600	0.274	0.1872	PASS	0.0 ft	0.0	PASS	11.0 ft

**Maximum Reactions**

Note: Only non-zero reactions are listed.

Load Combination	X-X Axis Reaction		k	Y-Y Axis Reaction		Axial Reaction	My - End Moments		k-ft Mx - End Moments	
	@ Base	@ Top		@ Base	@ Top		@ Base	@ Top	@ Base	@ Top
+D+H						10.955				
+D+L+H						14.855				
+D+Lr+H						10.955				
+D+S+H						23.255				
+D+0.750Lr+0.750L+H						13.880				
+D+0.750L+0.750S+H						23.105				
+D+0.60W+H						10.955				
+D+0.750Lr+0.750L+0.450W+H						13.880				
+D+0.750L+0.750S+0.450W+H						23.105				
+0.60D+0.60W+0.60H						6.573				
+D+0.70E+0.60H						10.955				
+D+0.750L+0.750S+0.5250E+H						23.105				
+0.60D+0.70E+H						6.573				
D Only						10.955				
Lr Only										
L Only						3.900				
S Only						12.300				
W Only										
E Only										
H Only										

**Maximum Deflections for Load Combinations**

Load Combination	Max. X-X Deflection		Distance	Max. Y-Y Deflection		Distance
+D+H	0.000	0.000		0.000	0.000	
+D+L+H	0.000	0.000		0.000	0.000	
+D+Lr+H	0.000	0.000		0.000	0.000	
+D+S+H	0.000	0.000		0.000	0.000	
+D+0.750Lr+0.750L+H	0.000	0.000		0.000	0.000	
+D+0.750L+0.750S+H	0.000	0.000		0.000	0.000	
+D+0.60W+H	0.000	0.000		0.000	0.000	
+D+0.750Lr+0.750L+0.450W+H	0.000	0.000		0.000	0.000	
+D+0.750L+0.750S+0.450W+H	0.000	0.000		0.000	0.000	
+0.60D+0.60W+0.60H	0.000	0.000		0.000	0.000	
+D+0.70E+0.60H	0.000	0.000		0.000	0.000	
+D+0.750L+0.750S+0.5250E+H	0.000	0.000		0.000	0.000	
+0.60D+0.70E+H	0.000	0.000		0.000	0.000	
D Only	0.000	0.000		0.000	0.000	
Lr Only	0.000	0.000		0.000	0.000	
L Only	0.000	0.000		0.000	0.000	
S Only	0.000	0.000		0.000	0.000	
W Only	0.000	0.000		0.000	0.000	
E Only	0.000	0.000		0.000	0.000	
H Only	0.000	0.000		0.000	0.000	

## Wood Column

Lic. # : KW-06009431

DESCRIPTIO COL#3

### Sketches

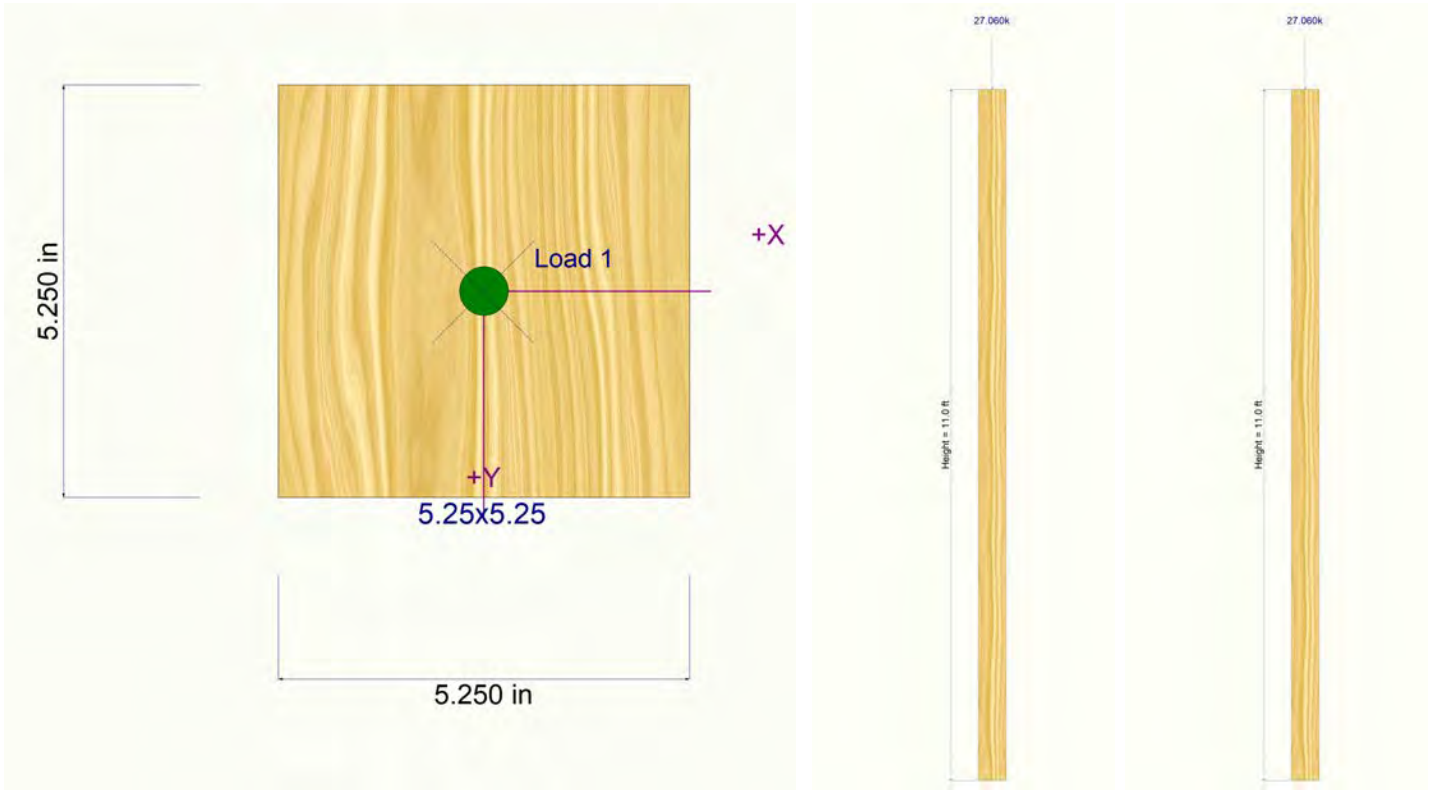

**General Footing**

Lic. # : KW-06009431

**DESCRIPTIO FTNG#1**

**Code References**

Calculations per ACI 318-14, IBC 2015, CBC 2016, ASCE 7-10  
 Load Combinations Used : ASCE 7-16

**General Information**

**Material Properties**

f <sub>c</sub> : Concrete 28 day strength	=	2.50 ksi
f <sub>y</sub> : Rebar Yield	=	60.0 ksi
E <sub>c</sub> : Concrete Elastic Modulus	=	3,122.0 ksi
Concrete Density	=	145.0 pcf
φ Values Flexure	=	0.90
Shear	=	0.750

**Soil Design Values**

Allowable Soil Beari	=	1.50 ksf
Increase Bearing By Footing Weight	=	No
Soil Passive Resistance (for Sliding)	=	150.0 pcf
Soil/Concrete Friction Coeff.	=	0.250

**Analysis Settings**

Min Steel % Bending Reinf.	=	
Min Allow % Temp Reinf.	=	0.00180
Min. Overturning Safety Factor	=	1.0 : 1
Min. Sliding Safety Factor	=	1.0 : 1
Add Ftg Wt for Soil Pressure	:	Yes
Use ftg wt for stability, moments & shears	:	Yes
Add Pedestal Wt for Soil Pressure	:	No
Use Pedestal wt for stability, mom & shear	:	No

**Increases based on footing Depth**

Footing base depth below soil surface	=	1.0 ft
Allow press. increase per foot of depth when footing base is below	=	ksf ft

**Increases based on footing plan dimension**

Allowable pressure increase per foot of depth when max. length or width is greater than	=	ksf
	=	ft

**Dimensions**

Width parallel to X-X Axis	=	4.0 ft
Length parallel to Z-Z Axis	=	4.0 ft
Footing Thickness	=	14.0 in

**Pedestal dimensions...**

px : parallel to X-X Axis	=	in
pz : parallel to Z-Z Axis	=	in
Height	=	in
Rebar Centerline to Edge of Concrete... at Bottom of footing	=	3.0 in

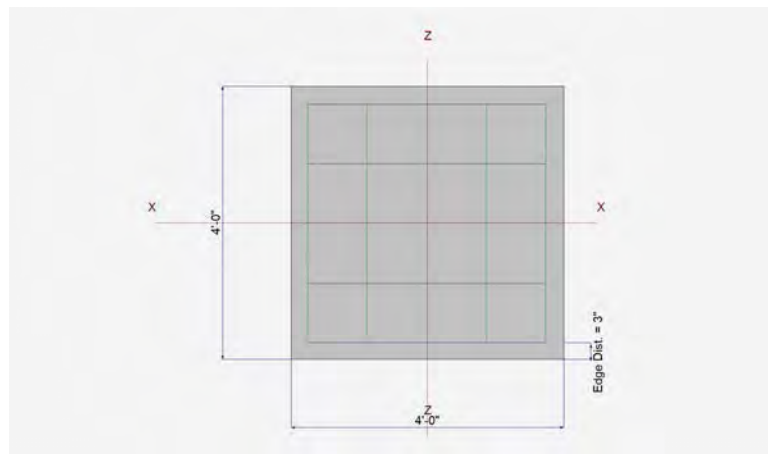

**Reinforcing**

Bars parallel to X-X Axis	=	
Number of Bars	=	5.0
Reinforcing Bar Size	=	# 5

Bars parallel to Z-Z Axis	=	
Number of Bars	=	5.0
Reinforcing Bar Size	=	# 5

**Bandwidth Distribution Check (ACI 15.4.4.2)**

Direction Requiring Closer Separatio	=	n/a
# Bars required within zone	=	n/a
# Bars required on each side of zone	=	n/a

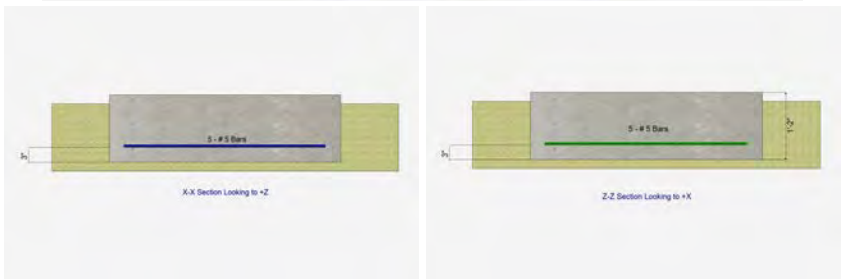

**Applied Loads**

	D	L <sub>r</sub>	L	S	W	E	H
P : Column Load	=	9.10		5.60	9.30		k
OB : Overburden	=						ksf
M-xx	=						k-ft
M-zz	=						k-ft
V-x	=						k
V-z	=						k



**General Footing**

Lic. #: KW-06009431

**DESCRIPTIO FTNG#1**

**DESIGN SUMMARY**

**Design OK**

	Min. Ratio	Item	Applied	Capacity	Governing Load Combination
PASS	0.9573	Soil Bearing	1.436 ksf	1.50 ksf	+D+0.750L+0.750S+0.5250E+H ε
PASS	n/a	Overturing - X-X	0.0 k-ft	0.0 k-ft	No Overturing
PASS	n/a	Overturing - Z-Z	0.0 k-ft	0.0 k-ft	No Overturing
PASS	n/a	Sliding - X-X	0.0 k	0.0 k	No Sliding
PASS	n/a	Sliding - Z-Z	0.0 k	0.0 k	No Sliding
PASS	n/a	Uplift	0.0 k	0.0 k	No Uplift
PASS	0.2135	Z Flexure (+X)	3.925 k-ft/ft	18.386 k-ft/ft	+1.20D+L+1.60S+1.60H
PASS	0.2135	Z Flexure (-X)	3.925 k-ft/ft	18.386 k-ft/ft	+1.20D+L+1.60S+1.60H
PASS	0.2135	X Flexure (+Z)	3.925 k-ft/ft	18.386 k-ft/ft	+1.20D+L+1.60S+1.60H
PASS	0.2135	X Flexure (-Z)	3.925 k-ft/ft	18.386 k-ft/ft	+1.20D+L+1.60S+1.60H
PASS	0.2141	1-way Shear (+X)	16.057 psi	75.0 psi	+1.20D+L+1.60S+1.60H
PASS	0.2141	1-way Shear (-X)	16.057 psi	75.0 psi	+1.20D+L+1.60S+1.60H
PASS	0.2141	1-way Shear (+Z)	16.057 psi	75.0 psi	+1.20D+L+1.60S+1.60H
PASS	0.2141	1-way Shear (-Z)	16.057 psi	75.0 psi	+1.20D+L+1.60S+1.60H
PASS	0.4116	2-way Punching	61.736 psi	150.0 psi	+1.20D+L+1.60S+1.60H

**Detailed Results**

**Soil Bearing**

Rotation Axis & Load Combination...	Gross Allowable	Xecc	Zecc (in)	Actual Soil Bearing Stress @ Location				Actual / Allow Ratio
				Bottom, -Z	Top, +Z	Left, -X	Right, +X	
X-X, +D+H	1.50	n/a	0.0	0.7379	0.7379	n/a	n/a	0.492
X-X, +D+L+H	1.50	n/a	0.0	1.088	1.088	n/a	n/a	0.725
X-X, +D+Lr+H	1.50	n/a	0.0	0.7379	0.7379	n/a	n/a	0.492
X-X, +D+S+H	1.50	n/a	0.0	1.319	1.319	n/a	n/a	0.879
X-X, +D+0.750Lr+0.750L+H	1.50	n/a	0.0	1.0	1.0	n/a	n/a	0.667
X-X, +D+0.750L+0.750S+H	1.50	n/a	0.0	1.436	1.436	n/a	n/a	0.957
X-X, +D+0.60W+H	1.50	n/a	0.0	0.7379	0.7379	n/a	n/a	0.492
X-X, +D+0.750Lr+0.750L+0.450W	1.50	n/a	0.0	1.0	1.0	n/a	n/a	0.667
X-X, +D+0.750L+0.750S+0.450W	1.50	n/a	0.0	1.436	1.436	n/a	n/a	0.957
X-X, +0.60D+0.60W+0.60H	1.50	n/a	0.0	0.4428	0.4428	n/a	n/a	0.295
X-X, +D+0.70E+0.60H	1.50	n/a	0.0	0.7379	0.7379	n/a	n/a	0.492
X-X, +D+0.750L+0.750S+0.5250E	1.50	n/a	0.0	1.436	1.436	n/a	n/a	0.957
X-X, +0.60D+0.70E+H	1.50	n/a	0.0	0.4428	0.4428	n/a	n/a	0.295
Z-Z, +D+H	1.50	0.0	n/a	n/a	n/a	0.7379	0.7379	0.492
Z-Z, +D+L+H	1.50	0.0	n/a	n/a	n/a	1.088	1.088	0.725
Z-Z, +D+Lr+H	1.50	0.0	n/a	n/a	n/a	0.7379	0.7379	0.492
Z-Z, +D+S+H	1.50	0.0	n/a	n/a	n/a	1.319	1.319	0.879
Z-Z, +D+0.750Lr+0.750L+H	1.50	0.0	n/a	n/a	n/a	1.0	1.0	0.667
Z-Z, +D+0.750L+0.750S+H	1.50	0.0	n/a	n/a	n/a	1.436	1.436	0.957
Z-Z, +D+0.60W+H	1.50	0.0	n/a	n/a	n/a	0.7379	0.7379	0.492
Z-Z, +D+0.750Lr+0.750L+0.450W	1.50	0.0	n/a	n/a	n/a	1.0	1.0	0.667
Z-Z, +D+0.750L+0.750S+0.450W	1.50	0.0	n/a	n/a	n/a	1.436	1.436	0.957
Z-Z, +0.60D+0.60W+0.60H	1.50	0.0	n/a	n/a	n/a	0.4428	0.4428	0.295
Z-Z, +D+0.70E+0.60H	1.50	0.0	n/a	n/a	n/a	0.7379	0.7379	0.492
Z-Z, +D+0.750L+0.750S+0.5250E	1.50	0.0	n/a	n/a	n/a	1.436	1.436	0.957
Z-Z, +0.60D+0.70E+H	1.50	0.0	n/a	n/a	n/a	0.4428	0.4428	0.295

**Overturing Stability**

Rotation Axis & Load Combination...	Overturing Moment	Resisting Moment	Stability Ratio	Status
Footing Has NO Overturing				

**Sliding Stability**

All units k

Force Application Axis Load Combination...	Sliding Force	Resisting Force	Stability Ratio	Status
Footing Has NO Sliding				

Feaster Residence  
 7544 31st Ave NW  
 Seattle, WA 98117  
 Permit # 6736413 - CM

Project Title:  
 Engineer:  
 Project ID:  
 Project Descr:

Printed: 12 JAN 2020, 10:14AM

**General Footing**

File = C:\Users\pasko\Desktop\test.ec6 .

Software copyright ENERCALC, INC. 1983-2019, Build:12.19.11.30 .

Lic. #: KW-06009431

CK Engineering LLC

**DESCRIPTIO FTNG#1**

**Footing Flexure**

Flexure Axis & Load Combination	Mu k-ft	Side	Tension Surface	As Req'd in^2	Gvrn. As in^2	Actual As in^2	Phi*Mn k-ft	Status
X-X, +1.40D+1.60H	1.593	+Z	Bottom	0.3024	Min Temp %	0.3875	18.386	OK
X-X, +1.40D+1.60H	1.593	-Z	Bottom	0.3024	Min Temp %	0.3875	18.386	OK
X-X, +1.20D+0.50Lr+1.60L+1.60H	2.485	+Z	Bottom	0.3024	Min Temp %	0.3875	18.386	OK
X-X, +1.20D+0.50Lr+1.60L+1.60H	2.485	-Z	Bottom	0.3024	Min Temp %	0.3875	18.386	OK
X-X, +1.20D+1.60L+0.50S+1.60H	3.066	+Z	Bottom	0.3024	Min Temp %	0.3875	18.386	OK
X-X, +1.20D+1.60L+0.50S+1.60H	3.066	-Z	Bottom	0.3024	Min Temp %	0.3875	18.386	OK
X-X, +1.20D+1.60Lr+L+1.60H	2.065	+Z	Bottom	0.3024	Min Temp %	0.3875	18.386	OK
X-X, +1.20D+1.60Lr+L+1.60H	2.065	-Z	Bottom	0.3024	Min Temp %	0.3875	18.386	OK
X-X, +1.20D+1.60Lr+0.50W+1.60	1.365	+Z	Bottom	0.3024	Min Temp %	0.3875	18.386	OK
X-X, +1.20D+1.60Lr+0.50W+1.60	1.365	-Z	Bottom	0.3024	Min Temp %	0.3875	18.386	OK
X-X, +1.20D+L+1.60S+1.60H	3.925	+Z	Bottom	0.3024	Min Temp %	0.3875	18.386	OK
X-X, +1.20D+L+1.60S+1.60H	3.925	-Z	Bottom	0.3024	Min Temp %	0.3875	18.386	OK
X-X, +1.20D+1.60S+0.50W+1.60H	3.225	+Z	Bottom	0.3024	Min Temp %	0.3875	18.386	OK
X-X, +1.20D+1.60S+0.50W+1.60H	3.225	-Z	Bottom	0.3024	Min Temp %	0.3875	18.386	OK
X-X, +1.20D+0.50Lr+L+W+1.60H	2.065	+Z	Bottom	0.3024	Min Temp %	0.3875	18.386	OK
X-X, +1.20D+0.50Lr+L+W+1.60H	2.065	-Z	Bottom	0.3024	Min Temp %	0.3875	18.386	OK
X-X, +1.20D+L+0.50S+W+1.60H	2.646	+Z	Bottom	0.3024	Min Temp %	0.3875	18.386	OK
X-X, +1.20D+L+0.50S+W+1.60H	2.646	-Z	Bottom	0.3024	Min Temp %	0.3875	18.386	OK
X-X, +0.90D+W+1.60H	1.024	+Z	Bottom	0.3024	Min Temp %	0.3875	18.386	OK
X-X, +0.90D+W+1.60H	1.024	-Z	Bottom	0.3024	Min Temp %	0.3875	18.386	OK
X-X, +1.20D+L+0.20S+E+1.60H	2.298	+Z	Bottom	0.3024	Min Temp %	0.3875	18.386	OK
X-X, +1.20D+L+0.20S+E+1.60H	2.298	-Z	Bottom	0.3024	Min Temp %	0.3875	18.386	OK
X-X, +0.90D+E+0.90H	1.024	+Z	Bottom	0.3024	Min Temp %	0.3875	18.386	OK
X-X, +0.90D+E+0.90H	1.024	-Z	Bottom	0.3024	Min Temp %	0.3875	18.386	OK
Z-Z, +1.40D+1.60H	1.593	-X	Bottom	0.3024	Min Temp %	0.3875	18.386	OK
Z-Z, +1.40D+1.60H	1.593	+X	Bottom	0.3024	Min Temp %	0.3875	18.386	OK
Z-Z, +1.20D+0.50Lr+1.60L+1.60H	2.485	-X	Bottom	0.3024	Min Temp %	0.3875	18.386	OK
Z-Z, +1.20D+0.50Lr+1.60L+1.60H	2.485	+X	Bottom	0.3024	Min Temp %	0.3875	18.386	OK
Z-Z, +1.20D+1.60L+0.50S+1.60H	3.066	-X	Bottom	0.3024	Min Temp %	0.3875	18.386	OK
Z-Z, +1.20D+1.60L+0.50S+1.60H	3.066	+X	Bottom	0.3024	Min Temp %	0.3875	18.386	OK
Z-Z, +1.20D+1.60Lr+L+1.60H	2.065	-X	Bottom	0.3024	Min Temp %	0.3875	18.386	OK
Z-Z, +1.20D+1.60Lr+L+1.60H	2.065	+X	Bottom	0.3024	Min Temp %	0.3875	18.386	OK
Z-Z, +1.20D+1.60Lr+0.50W+1.60	1.365	-X	Bottom	0.3024	Min Temp %	0.3875	18.386	OK
Z-Z, +1.20D+1.60Lr+0.50W+1.60	1.365	+X	Bottom	0.3024	Min Temp %	0.3875	18.386	OK
Z-Z, +1.20D+L+1.60S+1.60H	3.925	-X	Bottom	0.3024	Min Temp %	0.3875	18.386	OK
Z-Z, +1.20D+L+1.60S+1.60H	3.925	+X	Bottom	0.3024	Min Temp %	0.3875	18.386	OK
Z-Z, +1.20D+1.60S+0.50W+1.60H	3.225	-X	Bottom	0.3024	Min Temp %	0.3875	18.386	OK
Z-Z, +1.20D+1.60S+0.50W+1.60H	3.225	+X	Bottom	0.3024	Min Temp %	0.3875	18.386	OK
Z-Z, +1.20D+0.50Lr+L+W+1.60H	2.065	-X	Bottom	0.3024	Min Temp %	0.3875	18.386	OK
Z-Z, +1.20D+0.50Lr+L+W+1.60H	2.065	+X	Bottom	0.3024	Min Temp %	0.3875	18.386	OK
Z-Z, +1.20D+L+0.50S+W+1.60H	2.646	-X	Bottom	0.3024	Min Temp %	0.3875	18.386	OK
Z-Z, +1.20D+L+0.50S+W+1.60H	2.646	+X	Bottom	0.3024	Min Temp %	0.3875	18.386	OK
Z-Z, +0.90D+W+1.60H	1.024	-X	Bottom	0.3024	Min Temp %	0.3875	18.386	OK
Z-Z, +0.90D+W+1.60H	1.024	+X	Bottom	0.3024	Min Temp %	0.3875	18.386	OK
Z-Z, +1.20D+L+0.20S+E+1.60H	2.298	-X	Bottom	0.3024	Min Temp %	0.3875	18.386	OK
Z-Z, +1.20D+L+0.20S+E+1.60H	2.298	+X	Bottom	0.3024	Min Temp %	0.3875	18.386	OK
Z-Z, +0.90D+E+0.90H	1.024	-X	Bottom	0.3024	Min Temp %	0.3875	18.386	OK
Z-Z, +0.90D+E+0.90H	1.024	+X	Bottom	0.3024	Min Temp %	0.3875	18.386	OK

**One Way Shear**

Load Combination...	Vu @ -X	Vu @ +X	Vu @ -Z	Vu @ +Z	Vu:Max	Phi Vn	Vu / Phi*Vn	Status
+1.40D+1.60H	6.52 psi	6.52 psi	6.52 psi	6.52 psi	6.52 psi	75.00 psi	0.09	OK
+1.20D+0.50Lr+1.60L+1.60H	10.17 psi	10.17 psi	10.17 psi	10.17 psi	10.17 psi	75.00 psi	0.14	OK
+1.20D+1.60L+0.50S+1.60H	12.54 psi	12.54 psi	12.54 psi	12.54 psi	12.54 psi	75.00 psi	0.17	OK
+1.20D+1.60Lr+L+1.60H	8.45 psi	8.45 psi	8.45 psi	8.45 psi	8.45 psi	75.00 psi	0.11	OK
+1.20D+1.60Lr+0.50W+1.60H	5.58 psi	5.58 psi	5.58 psi	5.58 psi	5.58 psi	75.00 psi	0.07	OK
+1.20D+L+1.60S+1.60H	16.06 psi	16.06 psi	16.06 psi	16.06 psi	16.06 psi	75.00 psi	0.21	OK
+1.20D+1.60S+0.50W+1.60H	13.19 psi	13.19 psi	13.19 psi	13.19 psi	13.19 psi	75.00 psi	0.18	OK
+1.20D+0.50Lr+L+W+1.60H	8.45 psi	8.45 psi	8.45 psi	8.45 psi	8.45 psi	75.00 psi	0.11	OK
+1.20D+L+0.50S+W+1.60H	10.83 psi	10.83 psi	10.83 psi	10.83 psi	10.83 psi	75.00 psi	0.14	OK
+0.90D+W+1.60H	4.19 psi	4.19 psi	4.19 psi	4.19 psi	4.19 psi	75.00 psi	0.06	OK
+1.20D+L+0.20S+E+1.60H	9.40 psi	9.40 psi	9.40 psi	9.40 psi	9.40 psi	75.00 psi	0.13	OK

Feaster Residence  
 7544 31st Ave NW  
 Seattle, WA 98117  
 Permit # 6736413 - CM

Project Title:  
 Engineer:  
 Project ID:  
 Project Descr:

Printed: 12 JAN 2020, 10:14AM

**General Footing**

File = C:\Users\pasko\Desktop\test.ec6 .  
 Software copyright ENERCALC, INC. 1983-2019, Build:12.19.11.30 .  
 CK Engineering LLC

Lic. # : KW-06009431

**DESCRIPTIO FTNG#1**

**One Way Shear**

Load Combination...	Vu @ -X	Vu @ +X	Vu @ -Z	Vu @ +Z	Vu:Max	Phi Vn	Vu / Phi*Vn	Status
+0.90D+E+0.90H	4.19 psi	4.19 psi	4.19 psi	4.19 psi	4.19 psi	75.00 psi	0.06	<b>OK</b>
<b>Two-Way "Punching" Shear</b>								All units k

Load Combination...	Vu	Phi*Vn	Vu / Phi*Vn	Status
+1.40D+1.60H	25.05 psi	150.00psi	0.167	<b>OK</b>
+1.20D+0.50Lr+1.60L+1.60H	39.09 psi	150.00psi	0.2606	<b>OK</b>
+1.20D+1.60L+0.50S+1.60H	48.23 psi	150.00psi	0.3215	<b>OK</b>
+1.20D+1.60Lr+L+1.60H	32.48 psi	150.00psi	0.2165	<b>OK</b>
+1.20D+1.60Lr+0.50W+1.60H	21.47 psi	150.00psi	0.1431	<b>OK</b>
+1.20D+L+1.60S+1.60H	61.74 psi	150.00psi	0.4116	<b>OK</b>
+1.20D+1.60S+0.50W+1.60H	50.73 psi	150.00psi	0.3382	<b>OK</b>
+1.20D+0.50Lr+L+W+1.60H	32.48 psi	150.00psi	0.2165	<b>OK</b>
+1.20D+L+0.50S+W+1.60H	41.62 psi	150.00psi	0.2775	<b>OK</b>
+0.90D+W+1.60H	16.10 psi	150.00psi	0.1074	<b>OK</b>
+1.20D+L+0.20S+E+1.60H	36.14 psi	150.00psi	0.2409	<b>OK</b>
+0.90D+E+0.90H	16.10 psi	150.00psi	0.1074	<b>OK</b>

**General Footing**

Lic. # : KW-06009431

**DESCRIPTIO FTNG#2**

**Code References**

Calculations per ACI 318-14, IBC 2015, CBC 2016, ASCE 7-10  
 Load Combinations Used : ASCE 7-16

**General Information**

**Material Properties**

f <sub>c</sub> : Concrete 28 day strength	=	2.50 ksi
f <sub>y</sub> : Rebar Yield	=	60.0 ksi
E <sub>c</sub> : Concrete Elastic Modulus	=	3,122.0 ksi
Concrete Density	=	145.0 pcf
φ Values Flexure	=	0.90
Shear	=	0.750

**Soil Design Values**

Allowable Soil Beari	=	1.50 ksf
Increase Bearing By Footing Weight	=	No
Soil Passive Resistance (for Sliding)	=	150.0 pcf
Soil/Concrete Friction Coeff.	=	0.250

**Analysis Settings**

Min Steel % Bending Reinf.	=	
Min Allow % Temp Reinf.	=	0.00180
Min. Overturning Safety Factor	=	1.0 : 1
Min. Sliding Safety Factor	=	1.0 : 1
Add Ftg Wt for Soil Pressure	:	Yes
Use ftg wt for stability, moments & shears	:	Yes
Add Pedestal Wt for Soil Pressure	:	No
Use Pedestal wt for stability, mom & shear	:	No

**Increases based on footing Depth**

Footing base depth below soil surface	=	1.0 ft
Allow press. increase per foot of depth when footing base is below	=	ksf ft

**Increases based on footing plan dimension**

Allowable pressure increase per foot of depth when max. length or width is greater than	=	ksf
	=	ft

**Dimensions**

Width parallel to X-X Axis	=	3.50 ft
Length parallel to Z-Z Axis	=	3.50 ft
Footing Thickness	=	14 in

**Pedestal dimensions...**

px : parallel to X-X Axis	=	in
pz : parallel to Z-Z Axis	=	in
Height	=	in
Rebar Centerline to Edge of Concrete... at Bottom of footing	=	3.0 in

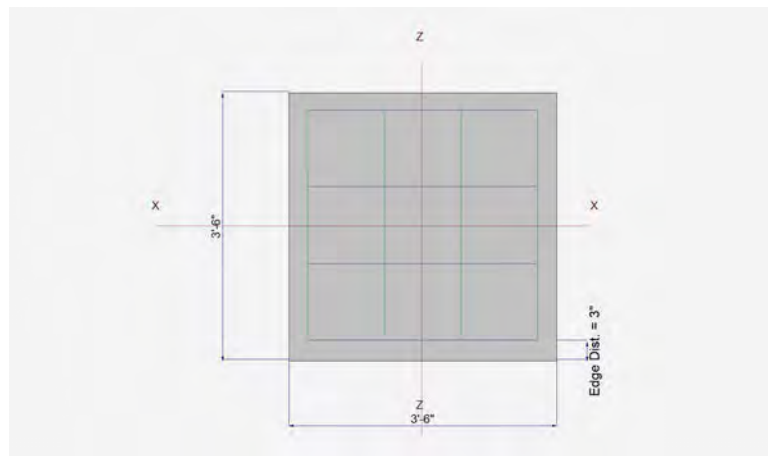

**Reinforcing**

Bars parallel to X-X Axis	=	
Number of Bars	=	4
Reinforcing Bar Size	=	# 5

Bars parallel to Z-Z Axis	=	
Number of Bars	=	4
Reinforcing Bar Size	=	# 5

**Bandwidth Distribution Check (ACI 15.4.4.2)**

Direction Requiring Closer Separatio	=	n/a
# Bars required within zone	=	n/a
# Bars required on each side of zone	=	n/a

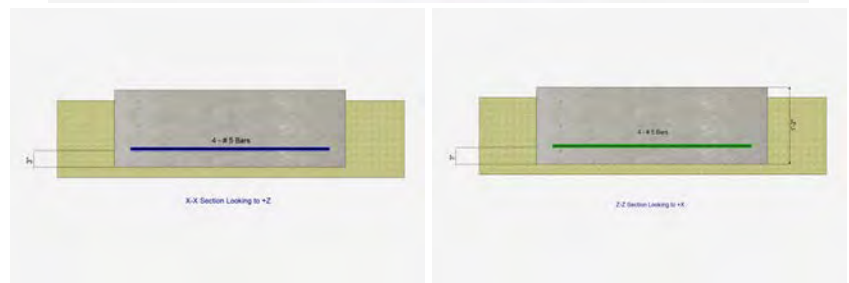

**Applied Loads**

	D	L <sub>r</sub>	L	S	W	E	H
P : Column Load	=	5.470		2.320	5.650		k
OB : Overburden	=						ksf
M-xx	=						k-ft
M-zz	=						k-ft
V-x	=						k
V-z	=						k

**General Footing**

Lic. # : KW-06009431

**DESCRIPTIO FTNG#2**

**DESIGN SUMMARY**

**Design OK**

	Min. Ratio	Item	Applied	Capacity	Governing Load Combination
PASS	0.7360	Soil Bearing	1.104 ksf	1.50 ksf	+D+0.750L+0.750S+0.5250E+H ε
PASS	n/a	Overturing - X-X	0.0 k-ft	0.0 k-ft	No Overturing
PASS	n/a	Overturing - Z-Z	0.0 k-ft	0.0 k-ft	No Overturing
PASS	n/a	Sliding - X-X	0.0 k	0.0 k	No Sliding
PASS	n/a	Sliding - Z-Z	0.0 k	0.0 k	No Sliding
PASS	n/a	Uplift	0.0 k	0.0 k	No Uplift
PASS	0.1328	Z Flexure (+X)	2.241 k-ft/ft	16.873 k-ft/ft	+1.20D+L+1.60S+1.60H
PASS	0.1328	Z Flexure (-X)	2.241 k-ft/ft	16.873 k-ft/ft	+1.20D+L+1.60S+1.60H
PASS	0.1328	X Flexure (+Z)	2.241 k-ft/ft	16.873 k-ft/ft	+1.20D+L+1.60S+1.60H
PASS	0.1328	X Flexure (-Z)	2.241 k-ft/ft	16.873 k-ft/ft	+1.20D+L+1.60S+1.60H
PASS	0.1241	1-way Shear (+X)	9.311 psi	75.0 psi	+1.20D+L+1.60S+1.60H
PASS	0.1241	1-way Shear (-X)	9.311 psi	75.0 psi	+1.20D+L+1.60S+1.60H
PASS	0.1241	1-way Shear (+Z)	9.311 psi	75.0 psi	+1.20D+L+1.60S+1.60H
PASS	0.1241	1-way Shear (-Z)	9.311 psi	75.0 psi	+1.20D+L+1.60S+1.60H
PASS	0.2302	2-way Punching	34.530 psi	150.0 psi	+1.20D+L+1.60S+1.60H

**Detailed Results**

**Soil Bearing**

Rotation Axis & Load Combination...	Gross Allowable	Xecc	Zecc (in)	Actual Soil Bearing Stress @ Location				Actual / Allow Ratio
				Bottom, -Z	Top, +Z	Left, -X	Right, +X	
X-X, +D+H	1.50	n/a	0.0	0.6157	0.6157	n/a	n/a	0.411
X-X, +D+L+H	1.50	n/a	0.0	0.8051	0.8051	n/a	n/a	0.537
X-X, +D+Lr+H	1.50	n/a	0.0	0.6157	0.6157	n/a	n/a	0.411
X-X, +D+S+H	1.50	n/a	0.0	1.077	1.077	n/a	n/a	0.718
X-X, +D+0.750Lr+0.750L+H	1.50	n/a	0.0	0.7577	0.7577	n/a	n/a	0.505
X-X, +D+0.750L+0.750S+H	1.50	n/a	0.0	1.104	1.104	n/a	n/a	0.736
X-X, +D+0.60W+H	1.50	n/a	0.0	0.6157	0.6157	n/a	n/a	0.411
X-X, +D+0.750Lr+0.750L+0.450W	1.50	n/a	0.0	0.7577	0.7577	n/a	n/a	0.505
X-X, +D+0.750L+0.750S+0.450W	1.50	n/a	0.0	1.104	1.104	n/a	n/a	0.736
X-X, +0.60D+0.60W+0.60H	1.50	n/a	0.0	0.3694	0.3694	n/a	n/a	0.246
X-X, +D+0.70E+0.60H	1.50	n/a	0.0	0.6157	0.6157	n/a	n/a	0.411
X-X, +D+0.750L+0.750S+0.5250E	1.50	n/a	0.0	1.104	1.104	n/a	n/a	0.736
X-X, +0.60D+0.70E+H	1.50	n/a	0.0	0.3694	0.3694	n/a	n/a	0.246
Z-Z, +D+H	1.50	0.0	n/a	n/a	n/a	0.6157	0.6157	0.411
Z-Z, +D+L+H	1.50	0.0	n/a	n/a	n/a	0.8051	0.8051	0.537
Z-Z, +D+Lr+H	1.50	0.0	n/a	n/a	n/a	0.6157	0.6157	0.411
Z-Z, +D+S+H	1.50	0.0	n/a	n/a	n/a	1.077	1.077	0.718
Z-Z, +D+0.750Lr+0.750L+H	1.50	0.0	n/a	n/a	n/a	0.7577	0.7577	0.505
Z-Z, +D+0.750L+0.750S+H	1.50	0.0	n/a	n/a	n/a	1.104	1.104	0.736
Z-Z, +D+0.60W+H	1.50	0.0	n/a	n/a	n/a	0.6157	0.6157	0.411
Z-Z, +D+0.750Lr+0.750L+0.450W	1.50	0.0	n/a	n/a	n/a	0.7577	0.7577	0.505
Z-Z, +D+0.750L+0.750S+0.450W	1.50	0.0	n/a	n/a	n/a	1.104	1.104	0.736
Z-Z, +0.60D+0.60W+0.60H	1.50	0.0	n/a	n/a	n/a	0.3694	0.3694	0.246
Z-Z, +D+0.70E+0.60H	1.50	0.0	n/a	n/a	n/a	0.6157	0.6157	0.411
Z-Z, +D+0.750L+0.750S+0.5250E	1.50	0.0	n/a	n/a	n/a	1.104	1.104	0.736
Z-Z, +0.60D+0.70E+H	1.50	0.0	n/a	n/a	n/a	0.3694	0.3694	0.246

**Overturing Stability**

Rotation Axis & Load Combination...	Overturing Moment	Resisting Moment	Stability Ratio	Status
Footing Has NO Overturing				

**Sliding Stability**

All units k

Force Application Axis Load Combination...	Sliding Force	Resisting Force	Stability Ratio	Status
Footing Has NO Sliding				



**General Footing**

Lic. # : KW-06009431

**DESCRIPTIO FTNG#2**

**Footing Flexure**

Flexure Axis & Load Combination	Mu k-ft	Side	Tension Surface	As Req'd in^2	Gvrn. As in^2	Actual As in^2	Phi*Mn k-ft	Status
X-X, +1.40D+1.60H	0.9573	+Z	Bottom	0.3024	Min Temp %	0.3543	16.873	OK
X-X, +1.40D+1.60H	0.9573	-Z	Bottom	0.3024	Min Temp %	0.3543	16.873	OK
X-X, +1.20D+0.50Lr+1.60L+1.60H	1.285	+Z	Bottom	0.3024	Min Temp %	0.3543	16.873	OK
X-X, +1.20D+0.50Lr+1.60L+1.60H	1.285	-Z	Bottom	0.3024	Min Temp %	0.3543	16.873	OK
X-X, +1.20D+1.60L+0.50S+1.60H	1.638	+Z	Bottom	0.3024	Min Temp %	0.3543	16.873	OK
X-X, +1.20D+1.60L+0.50S+1.60H	1.638	-Z	Bottom	0.3024	Min Temp %	0.3543	16.873	OK
X-X, +1.20D+1.60Lr+L+1.60H	1.111	+Z	Bottom	0.3024	Min Temp %	0.3543	16.873	OK
X-X, +1.20D+1.60Lr+L+1.60H	1.111	-Z	Bottom	0.3024	Min Temp %	0.3543	16.873	OK
X-X, +1.20D+1.60Lr+0.50W+1.60H	0.8205	+Z	Bottom	0.3024	Min Temp %	0.3543	16.873	OK
X-X, +1.20D+1.60Lr+0.50W+1.60H	0.8205	-Z	Bottom	0.3024	Min Temp %	0.3543	16.873	OK
X-X, +1.20D+L+1.60S+1.60H	2.241	+Z	Bottom	0.3024	Min Temp %	0.3543	16.873	OK
X-X, +1.20D+L+1.60S+1.60H	2.241	-Z	Bottom	0.3024	Min Temp %	0.3543	16.873	OK
X-X, +1.20D+1.60S+0.50W+1.60H	1.951	+Z	Bottom	0.3024	Min Temp %	0.3543	16.873	OK
X-X, +1.20D+1.60S+0.50W+1.60H	1.951	-Z	Bottom	0.3024	Min Temp %	0.3543	16.873	OK
X-X, +1.20D+0.50Lr+L+W+1.60H	1.111	+Z	Bottom	0.3024	Min Temp %	0.3543	16.873	OK
X-X, +1.20D+0.50Lr+L+W+1.60H	1.111	-Z	Bottom	0.3024	Min Temp %	0.3543	16.873	OK
X-X, +1.20D+L+0.50S+W+1.60H	1.464	+Z	Bottom	0.3024	Min Temp %	0.3543	16.873	OK
X-X, +1.20D+L+0.50S+W+1.60H	1.464	-Z	Bottom	0.3024	Min Temp %	0.3543	16.873	OK
X-X, +0.90D+W+1.60H	0.6154	+Z	Bottom	0.3024	Min Temp %	0.3543	16.873	OK
X-X, +0.90D+W+1.60H	0.6154	-Z	Bottom	0.3024	Min Temp %	0.3543	16.873	OK
X-X, +1.20D+L+0.20S+E+1.60H	1.252	+Z	Bottom	0.3024	Min Temp %	0.3543	16.873	OK
X-X, +1.20D+L+0.20S+E+1.60H	1.252	-Z	Bottom	0.3024	Min Temp %	0.3543	16.873	OK
X-X, +0.90D+E+0.90H	0.6154	+Z	Bottom	0.3024	Min Temp %	0.3543	16.873	OK
X-X, +0.90D+E+0.90H	0.6154	-Z	Bottom	0.3024	Min Temp %	0.3543	16.873	OK
Z-Z, +1.40D+1.60H	0.9573	-X	Bottom	0.3024	Min Temp %	0.3543	16.873	OK
Z-Z, +1.40D+1.60H	0.9573	+X	Bottom	0.3024	Min Temp %	0.3543	16.873	OK
Z-Z, +1.20D+0.50Lr+1.60L+1.60H	1.285	-X	Bottom	0.3024	Min Temp %	0.3543	16.873	OK
Z-Z, +1.20D+0.50Lr+1.60L+1.60H	1.285	+X	Bottom	0.3024	Min Temp %	0.3543	16.873	OK
Z-Z, +1.20D+1.60L+0.50S+1.60H	1.638	-X	Bottom	0.3024	Min Temp %	0.3543	16.873	OK
Z-Z, +1.20D+1.60L+0.50S+1.60H	1.638	+X	Bottom	0.3024	Min Temp %	0.3543	16.873	OK
Z-Z, +1.20D+1.60Lr+L+1.60H	1.111	-X	Bottom	0.3024	Min Temp %	0.3543	16.873	OK
Z-Z, +1.20D+1.60Lr+L+1.60H	1.111	+X	Bottom	0.3024	Min Temp %	0.3543	16.873	OK
Z-Z, +1.20D+1.60Lr+0.50W+1.60H	0.8205	-X	Bottom	0.3024	Min Temp %	0.3543	16.873	OK
Z-Z, +1.20D+1.60Lr+0.50W+1.60H	0.8205	+X	Bottom	0.3024	Min Temp %	0.3543	16.873	OK
Z-Z, +1.20D+L+1.60S+1.60H	2.241	-X	Bottom	0.3024	Min Temp %	0.3543	16.873	OK
Z-Z, +1.20D+L+1.60S+1.60H	2.241	+X	Bottom	0.3024	Min Temp %	0.3543	16.873	OK
Z-Z, +1.20D+1.60S+0.50W+1.60H	1.951	-X	Bottom	0.3024	Min Temp %	0.3543	16.873	OK
Z-Z, +1.20D+1.60S+0.50W+1.60H	1.951	+X	Bottom	0.3024	Min Temp %	0.3543	16.873	OK
Z-Z, +1.20D+0.50Lr+L+W+1.60H	1.111	-X	Bottom	0.3024	Min Temp %	0.3543	16.873	OK
Z-Z, +1.20D+0.50Lr+L+W+1.60H	1.111	+X	Bottom	0.3024	Min Temp %	0.3543	16.873	OK
Z-Z, +1.20D+L+0.50S+W+1.60H	1.464	-X	Bottom	0.3024	Min Temp %	0.3543	16.873	OK
Z-Z, +1.20D+L+0.50S+W+1.60H	1.464	+X	Bottom	0.3024	Min Temp %	0.3543	16.873	OK
Z-Z, +0.90D+W+1.60H	0.6154	-X	Bottom	0.3024	Min Temp %	0.3543	16.873	OK
Z-Z, +0.90D+W+1.60H	0.6154	+X	Bottom	0.3024	Min Temp %	0.3543	16.873	OK
Z-Z, +1.20D+L+0.20S+E+1.60H	1.252	-X	Bottom	0.3024	Min Temp %	0.3543	16.873	OK
Z-Z, +1.20D+L+0.20S+E+1.60H	1.252	+X	Bottom	0.3024	Min Temp %	0.3543	16.873	OK
Z-Z, +0.90D+E+0.90H	0.6154	-X	Bottom	0.3024	Min Temp %	0.3543	16.873	OK
Z-Z, +0.90D+E+0.90H	0.6154	+X	Bottom	0.3024	Min Temp %	0.3543	16.873	OK

**One Way Shear**

Load Combination...	Vu @ -X	Vu @ +X	Vu @ -Z	Vu @ +Z	Vu:Max	Phi Vn	Vu / Phi*Vn	Status
+1.40D+1.60H	3.98 psi	3.98 psi	3.98 psi	3.98 psi	3.98 psi	75.00 psi	0.05	OK
+1.20D+0.50Lr+1.60L+1.60H	5.34 psi	5.34 psi	5.34 psi	5.34 psi	5.34 psi	75.00 psi	0.07	OK
+1.20D+1.60L+0.50S+1.60H	6.81 psi	6.81 psi	6.81 psi	6.81 psi	6.81 psi	75.00 psi	0.09	OK
+1.20D+1.60Lr+L+1.60H	4.62 psi	4.62 psi	4.62 psi	4.62 psi	4.62 psi	75.00 psi	0.06	OK
+1.20D+1.60Lr+0.50W+1.60H	3.41 psi	3.41 psi	3.41 psi	3.41 psi	3.41 psi	75.00 psi	0.05	OK
+1.20D+L+1.60S+1.60H	9.31 psi	9.31 psi	9.31 psi	9.31 psi	9.31 psi	75.00 psi	0.12	OK
+1.20D+1.60S+0.50W+1.60H	8.11 psi	8.11 psi	8.11 psi	8.11 psi	8.11 psi	75.00 psi	0.11	OK
+1.20D+0.50Lr+L+W+1.60H	4.62 psi	4.62 psi	4.62 psi	4.62 psi	4.62 psi	75.00 psi	0.06	OK
+1.20D+L+0.50S+W+1.60H	6.08 psi	6.08 psi	6.08 psi	6.08 psi	6.08 psi	75.00 psi	0.08	OK
+0.90D+W+1.60H	2.56 psi	2.56 psi	2.56 psi	2.56 psi	2.56 psi	75.00 psi	0.03	OK
+1.20D+L+0.20S+E+1.60H	5.20 psi	5.20 psi	5.20 psi	5.20 psi	5.20 psi	75.00 psi	0.07	OK

Feaster Residence  
 7544 31st Ave NW  
 Seattle, WA 98117  
 Permit # 6736413 - CM

Project Title:  
 Engineer:  
 Project ID:  
 Project Descr:

Printed: 12 JAN 2020, 10:15AM

**General Footing**

File = C:\Users\pasko\Desktop\test.ec6 .  
 Software copyright ENERCALC, INC. 1983-2019, Build:12.19.11.30 .  
 CK Engineering LLC

Lic. # : KW-06009431

**DESCRIPTIO FTNG#2**

**One Way Shear**

Load Combination...	Vu @ -X	Vu @ +X	Vu @ -Z	Vu @ +Z	Vu:Max	Phi Vn	Vu / Phi*Vn	Status
+0.90D+E+0.90H	2.56 psi	2.56 psi	2.56 psi	2.56 psi	2.56 psi	75.00 psi	0.03	<b>OK</b>
<b>Two-Way "Punching" Shear</b>								All units k

Load Combination...	Vu	Phi*Vn	Vu / Phi*Vn	Status
+1.40D+1.60H	14.75 psi	150.00psi	0.09835	<b>OK</b>
+1.20D+0.50Lr+1.60L+1.60H	19.80 psi	150.00psi	0.132	<b>OK</b>
+1.20D+1.60L+0.50S+1.60H	25.24 psi	150.00psi	0.1683	<b>OK</b>
+1.20D+1.60Lr+L+1.60H	17.12 psi	150.00psi	0.1141	<b>OK</b>
+1.20D+1.60Lr+0.50W+1.60H	12.65 psi	150.00psi	0.0843	<b>OK</b>
+1.20D+L+1.60S+1.60H	34.53 psi	150.00psi	0.2302	<b>OK</b>
+1.20D+1.60S+0.50W+1.60H	30.06 psi	150.00psi	0.2004	<b>OK</b>
+1.20D+0.50Lr+L+W+1.60H	17.12 psi	150.00psi	0.1141	<b>OK</b>
+1.20D+L+0.50S+W+1.60H	22.56 psi	150.00psi	0.1504	<b>OK</b>
+0.90D+W+1.60H	9.48 psi	150.00psi	0.06323	<b>OK</b>
+1.20D+L+0.20S+E+1.60H	19.29 psi	150.00psi	0.1286	<b>OK</b>
+0.90D+E+0.90H	9.48 psi	150.00psi	0.06323	<b>OK</b>

## General Footing

Lic. #: KW-06009431

### DESCRIPTIO FTNG#3

#### Code References

Calculations per ACI 318-14, IBC 2015, CBC 2016, ASCE 7-10  
 Load Combinations Used : ASCE 7-16

#### General Information

##### Material Properties

f <sub>c</sub> : Concrete 28 day strength	=	2.50 ksi
f <sub>y</sub> : Rebar Yield	=	60.0 ksi
E <sub>c</sub> : Concrete Elastic Modulus	=	3,122.0 ksi
Concrete Density	=	145.0 pcf
φ Values Flexure	=	0.90
Shear	=	0.750

##### Soil Design Values

Allowable Soil Beari	=	1.50 ksf
Increase Bearing By Footing Weight	=	No
Soil Passive Resistance (for Sliding)	=	150.0 pcf
Soil/Concrete Friction Coeff.	=	0.250

##### Analysis Settings

Min Steel % Bending Reinf.	=	
Min Allow % Temp Reinf.	=	0.00180
Min. Overturning Safety Factor	=	1.0 : 1
Min. Sliding Safety Factor	=	1.0 : 1
Add Ftg Wt for Soil Pressure	:	Yes
Use ftg wt for stability, moments & shears	:	Yes
Add Pedestal Wt for Soil Pressure	:	No
Use Pedestal wt for stability, mom & shear	:	No

##### Increases based on footing Depth

Footing base depth below soil surface	=	1.0 ft
Allow press. increase per foot of depth when footing base is below	=	ksf ft

##### Increases based on footing plan dimension

Allowable pressure increase per foot of depth when max. length or width is greater than	=	ksf
	=	ft

#### Dimensions

Width parallel to X-X Axis	=	4.50 ft
Length parallel to Z-Z Axis	=	4.50 ft
Footing Thickness	=	14.0 in

##### Pedestal dimensions...

px : parallel to X-X Axis	=	in
pz : parallel to Z-Z Axis	=	in
Height	=	in
Rebar Centerline to Edge of Concrete... at Bottom of footing	=	3.0 in

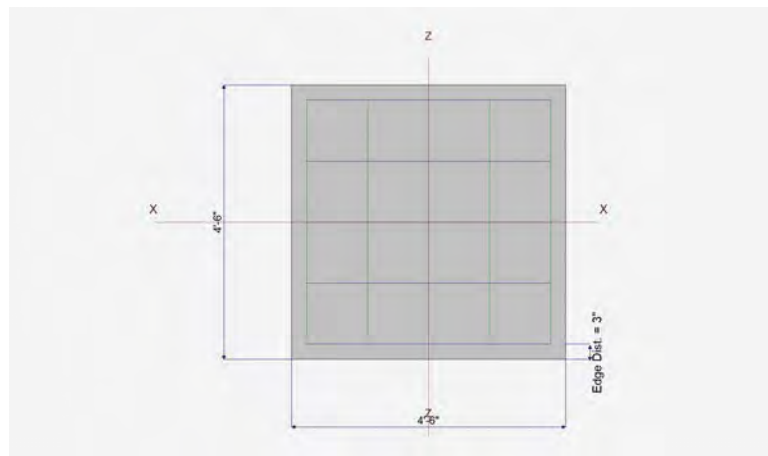

#### Reinforcing

Bars parallel to X-X Axis	=	
Number of Bars	=	5
Reinforcing Bar Size	=	# 5

Bars parallel to Z-Z Axis	=	
Number of Bars	=	5
Reinforcing Bar Size	=	# 5

##### Bandwidth Distribution Check (ACI 15.4.4.2)

Direction Requiring Closer Separatio	=	n/a
# Bars required within zone	=	n/a
# Bars required on each side of zone	=	n/a

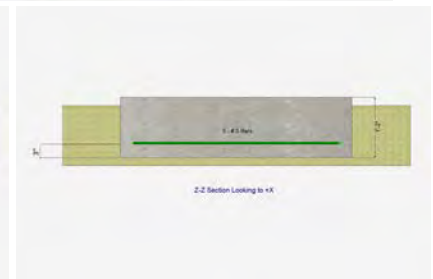
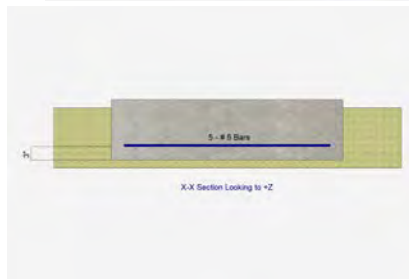

#### Applied Loads

	D	L <sub>r</sub>	L	S	W	E	H		
P : Column Load	=	10.860		3.90	12.30				k
OB : Overburden	=								ksf
M-xx	=								k-ft
M-zz	=								k-ft
V-x	=								k
V-z	=								k

**General Footing**

Lic. # : KW-06009431

**DESCRIPTIO FTNG#3**

**DESIGN SUMMARY**

**Design OK**

	Min. Ratio	Item	Applied	Capacity	Governing Load Combination
PASS	0.8753	Soil Bearing	1.313 ksf	1.50 ksf	+D+S+H about Z-Z axis
PASS	n/a	Overturing - X-X	0.0 k-ft	0.0 k-ft	No Overturing
PASS	n/a	Overturing - Z-Z	0.0 k-ft	0.0 k-ft	No Overturing
PASS	n/a	Sliding - X-X	0.0 k	0.0 k	No Sliding
PASS	n/a	Sliding - Z-Z	0.0 k	0.0 k	No Sliding
PASS	n/a	Uplift	0.0 k	0.0 k	No Uplift
PASS	0.2787	Z Flexure (+X)	4.577 k-ft/ft	16.422 k-ft/ft	+1.20D+L+1.60S+1.60H
PASS	0.2787	Z Flexure (-X)	4.577 k-ft/ft	16.422 k-ft/ft	+1.20D+L+1.60S+1.60H
PASS	0.2787	X Flexure (+Z)	4.577 k-ft/ft	16.422 k-ft/ft	+1.20D+L+1.60S+1.60H
PASS	0.2787	X Flexure (-Z)	4.577 k-ft/ft	16.422 k-ft/ft	+1.20D+L+1.60S+1.60H
PASS	0.2465	1-way Shear (+X)	18.491 psi	75.0 psi	+1.20D+L+1.60S+1.60H
PASS	0.2465	1-way Shear (-X)	18.491 psi	75.0 psi	+1.20D+L+1.60S+1.60H
PASS	0.2465	1-way Shear (+Z)	18.491 psi	75.0 psi	+1.20D+L+1.60S+1.60H
PASS	0.2465	1-way Shear (-Z)	18.491 psi	75.0 psi	+1.20D+L+1.60S+1.60H
PASS	0.4841	2-way Punching	72.619 psi	150.0 psi	+1.20D+L+1.60S+1.60H

**Detailed Results**

**Soil Bearing**

Rotation Axis & Load Combination...	Gross Allowable	Xecc	Zecc (in)	Actual Soil Bearing Stress @ Location				Actual / Allow Ratio
				Bottom, -Z	Top, +Z	Left, -X	Right, +X	
X-X, +D+H	1.50	n/a	0.0	0.7055	0.7055	n/a	n/a	0.470
X-X, +D+L+H	1.50	n/a	0.0	0.8981	0.8981	n/a	n/a	0.599
X-X, +D+Lr+H	1.50	n/a	0.0	0.7055	0.7055	n/a	n/a	0.470
X-X, +D+S+H	1.50	n/a	0.0	1.313	1.313	n/a	n/a	0.875
X-X, +D+0.750Lr+0.750L+H	1.50	n/a	0.0	0.8499	0.8499	n/a	n/a	0.567
X-X, +D+0.750L+0.750S+H	1.50	n/a	0.0	1.305	1.305	n/a	n/a	0.870
X-X, +D+0.60W+H	1.50	n/a	0.0	0.7055	0.7055	n/a	n/a	0.470
X-X, +D+0.750Lr+0.750L+0.450W	1.50	n/a	0.0	0.8499	0.8499	n/a	n/a	0.567
X-X, +D+0.750L+0.750S+0.450W	1.50	n/a	0.0	1.305	1.305	n/a	n/a	0.870
X-X, +0.60D+0.60W+0.60H	1.50	n/a	0.0	0.4233	0.4233	n/a	n/a	0.282
X-X, +D+0.70E+0.60H	1.50	n/a	0.0	0.7055	0.7055	n/a	n/a	0.470
X-X, +D+0.750L+0.750S+0.5250E	1.50	n/a	0.0	1.305	1.305	n/a	n/a	0.870
X-X, +0.60D+0.70E+H	1.50	n/a	0.0	0.4233	0.4233	n/a	n/a	0.282
Z-Z, +D+H	1.50	0.0	n/a	n/a	n/a	0.7055	0.7055	0.470
Z-Z, +D+L+H	1.50	0.0	n/a	n/a	n/a	0.8981	0.8981	0.599
Z-Z, +D+Lr+H	1.50	0.0	n/a	n/a	n/a	0.7055	0.7055	0.470
Z-Z, +D+S+H	1.50	0.0	n/a	n/a	n/a	1.313	1.313	0.875
Z-Z, +D+0.750Lr+0.750L+H	1.50	0.0	n/a	n/a	n/a	0.8499	0.8499	0.567
Z-Z, +D+0.750L+0.750S+H	1.50	0.0	n/a	n/a	n/a	1.305	1.305	0.870
Z-Z, +D+0.60W+H	1.50	0.0	n/a	n/a	n/a	0.7055	0.7055	0.470
Z-Z, +D+0.750Lr+0.750L+0.450W	1.50	0.0	n/a	n/a	n/a	0.8499	0.8499	0.567
Z-Z, +D+0.750L+0.750S+0.450W	1.50	0.0	n/a	n/a	n/a	1.305	1.305	0.870
Z-Z, +0.60D+0.60W+0.60H	1.50	0.0	n/a	n/a	n/a	0.4233	0.4233	0.282
Z-Z, +D+0.70E+0.60H	1.50	0.0	n/a	n/a	n/a	0.7055	0.7055	0.470
Z-Z, +D+0.750L+0.750S+0.5250E	1.50	0.0	n/a	n/a	n/a	1.305	1.305	0.870
Z-Z, +0.60D+0.70E+H	1.50	0.0	n/a	n/a	n/a	0.4233	0.4233	0.282

**Overturing Stability**

Rotation Axis & Load Combination...	Overturing Moment	Resisting Moment	Stability Ratio	Status
Footing Has NO Overturing				

**Sliding Stability**

All units k

Force Application Axis Load Combination...	Sliding Force	Resisting Force	Stability Ratio	Status
Footing Has NO Sliding				

Feaster Residence  
 7544 31st Ave NW  
 Seattle, WA 98117  
 Permit # 6736413 - CM

Project Title:  
 Engineer:  
 Project ID:  
 Project Descr:

Printed: 12 JAN 2020, 10:15AM

**General Footing**

File = C:\Users\pasko\Desktop\test.ec6 .

Software copyright ENERCALC, INC. 1983-2019, Build:12.19.11.30 .

Lic. #: KW-06009431

CK Engineering LLC

**DESCRIPTIO FTNG#3**

**Footing Flexure**

Flexure Axis & Load Combination	Mu k-ft	Side	Tension Surface	As Req'd in^2	Gvrn. As in^2	Actual As in^2	Phi*Mn k-ft	Status
X-X, +1.40D+1.60H	1.901	+Z	Bottom	0.3024	Min Temp %	0.3444	16.422	OK
X-X, +1.40D+1.60H	1.901	-Z	Bottom	0.3024	Min Temp %	0.3444	16.422	OK
X-X, +1.20D+0.50Lr+1.60L+1.60H	2.409	+Z	Bottom	0.3024	Min Temp %	0.3444	16.422	OK
X-X, +1.20D+0.50Lr+1.60L+1.60H	2.409	-Z	Bottom	0.3024	Min Temp %	0.3444	16.422	OK
X-X, +1.20D+1.60L+0.50S+1.60H	3.178	+Z	Bottom	0.3024	Min Temp %	0.3444	16.422	OK
X-X, +1.20D+1.60L+0.50S+1.60H	3.178	-Z	Bottom	0.3024	Min Temp %	0.3444	16.422	OK
X-X, +1.20D+1.60Lr+L+1.60H	2.117	+Z	Bottom	0.3024	Min Temp %	0.3444	16.422	OK
X-X, +1.20D+1.60Lr+L+1.60H	2.117	-Z	Bottom	0.3024	Min Temp %	0.3444	16.422	OK
X-X, +1.20D+1.60Lr+0.50W+1.60H	1.629	+Z	Bottom	0.3024	Min Temp %	0.3444	16.422	OK
X-X, +1.20D+1.60Lr+0.50W+1.60H	1.629	-Z	Bottom	0.3024	Min Temp %	0.3444	16.422	OK
X-X, +1.20D+L+1.60S+1.60H	4.577	+Z	Bottom	0.3024	Min Temp %	0.3444	16.422	OK
X-X, +1.20D+L+1.60S+1.60H	4.577	-Z	Bottom	0.3024	Min Temp %	0.3444	16.422	OK
X-X, +1.20D+1.60S+0.50W+1.60H	4.089	+Z	Bottom	0.3024	Min Temp %	0.3444	16.422	OK
X-X, +1.20D+1.60S+0.50W+1.60H	4.089	-Z	Bottom	0.3024	Min Temp %	0.3444	16.422	OK
X-X, +1.20D+0.50Lr+L+W+1.60H	2.117	+Z	Bottom	0.3024	Min Temp %	0.3444	16.422	OK
X-X, +1.20D+0.50Lr+L+W+1.60H	2.117	-Z	Bottom	0.3024	Min Temp %	0.3444	16.422	OK
X-X, +1.20D+L+0.50S+W+1.60H	2.885	+Z	Bottom	0.3024	Min Temp %	0.3444	16.422	OK
X-X, +1.20D+L+0.50S+W+1.60H	2.885	-Z	Bottom	0.3024	Min Temp %	0.3444	16.422	OK
X-X, +0.90D+W+1.60H	1.222	+Z	Bottom	0.3024	Min Temp %	0.3444	16.422	OK
X-X, +0.90D+W+1.60H	1.222	-Z	Bottom	0.3024	Min Temp %	0.3444	16.422	OK
X-X, +1.20D+L+0.20S+E+1.60H	2.424	+Z	Bottom	0.3024	Min Temp %	0.3444	16.422	OK
X-X, +1.20D+L+0.20S+E+1.60H	2.424	-Z	Bottom	0.3024	Min Temp %	0.3444	16.422	OK
X-X, +0.90D+E+0.90H	1.222	+Z	Bottom	0.3024	Min Temp %	0.3444	16.422	OK
X-X, +0.90D+E+0.90H	1.222	-Z	Bottom	0.3024	Min Temp %	0.3444	16.422	OK
Z-Z, +1.40D+1.60H	1.901	-X	Bottom	0.3024	Min Temp %	0.3444	16.422	OK
Z-Z, +1.40D+1.60H	1.901	+X	Bottom	0.3024	Min Temp %	0.3444	16.422	OK
Z-Z, +1.20D+0.50Lr+1.60L+1.60H	2.409	-X	Bottom	0.3024	Min Temp %	0.3444	16.422	OK
Z-Z, +1.20D+0.50Lr+1.60L+1.60H	2.409	+X	Bottom	0.3024	Min Temp %	0.3444	16.422	OK
Z-Z, +1.20D+1.60L+0.50S+1.60H	3.178	-X	Bottom	0.3024	Min Temp %	0.3444	16.422	OK
Z-Z, +1.20D+1.60L+0.50S+1.60H	3.178	+X	Bottom	0.3024	Min Temp %	0.3444	16.422	OK
Z-Z, +1.20D+1.60Lr+L+1.60H	2.117	-X	Bottom	0.3024	Min Temp %	0.3444	16.422	OK
Z-Z, +1.20D+1.60Lr+L+1.60H	2.117	+X	Bottom	0.3024	Min Temp %	0.3444	16.422	OK
Z-Z, +1.20D+1.60Lr+0.50W+1.60H	1.629	-X	Bottom	0.3024	Min Temp %	0.3444	16.422	OK
Z-Z, +1.20D+1.60Lr+0.50W+1.60H	1.629	+X	Bottom	0.3024	Min Temp %	0.3444	16.422	OK
Z-Z, +1.20D+L+1.60S+1.60H	4.577	-X	Bottom	0.3024	Min Temp %	0.3444	16.422	OK
Z-Z, +1.20D+L+1.60S+1.60H	4.577	+X	Bottom	0.3024	Min Temp %	0.3444	16.422	OK
Z-Z, +1.20D+1.60S+0.50W+1.60H	4.089	-X	Bottom	0.3024	Min Temp %	0.3444	16.422	OK
Z-Z, +1.20D+1.60S+0.50W+1.60H	4.089	+X	Bottom	0.3024	Min Temp %	0.3444	16.422	OK
Z-Z, +1.20D+0.50Lr+L+W+1.60H	2.117	-X	Bottom	0.3024	Min Temp %	0.3444	16.422	OK
Z-Z, +1.20D+0.50Lr+L+W+1.60H	2.117	+X	Bottom	0.3024	Min Temp %	0.3444	16.422	OK
Z-Z, +1.20D+L+0.50S+W+1.60H	2.885	-X	Bottom	0.3024	Min Temp %	0.3444	16.422	OK
Z-Z, +1.20D+L+0.50S+W+1.60H	2.885	+X	Bottom	0.3024	Min Temp %	0.3444	16.422	OK
Z-Z, +0.90D+W+1.60H	1.222	-X	Bottom	0.3024	Min Temp %	0.3444	16.422	OK
Z-Z, +0.90D+W+1.60H	1.222	+X	Bottom	0.3024	Min Temp %	0.3444	16.422	OK
Z-Z, +1.20D+L+0.20S+E+1.60H	2.424	-X	Bottom	0.3024	Min Temp %	0.3444	16.422	OK
Z-Z, +1.20D+L+0.20S+E+1.60H	2.424	+X	Bottom	0.3024	Min Temp %	0.3444	16.422	OK
Z-Z, +0.90D+E+0.90H	1.222	-X	Bottom	0.3024	Min Temp %	0.3444	16.422	OK
Z-Z, +0.90D+E+0.90H	1.222	+X	Bottom	0.3024	Min Temp %	0.3444	16.422	OK

**One Way Shear**

Load Combination...	Vu @ -X	Vu @ +X	Vu @ -Z	Vu @ +Z	Vu:Max	Phi Vn	Vu / Phi*Vn	Status
+1.40D+1.60H	7.68 psi	7.68 psi	7.68 psi	7.68 psi	7.68 psi	75.00 psi	0.10	OK
+1.20D+0.50Lr+1.60L+1.60H	9.73 psi	9.73 psi	9.73 psi	9.73 psi	9.73 psi	75.00 psi	0.13	OK
+1.20D+1.60L+0.50S+1.60H	12.84 psi	12.84 psi	12.84 psi	12.84 psi	12.84 psi	75.00 psi	0.17	OK
+1.20D+1.60Lr+L+1.60H	8.55 psi	8.55 psi	8.55 psi	8.55 psi	8.55 psi	75.00 psi	0.11	OK
+1.20D+1.60Lr+0.50W+1.60H	6.58 psi	6.58 psi	6.58 psi	6.58 psi	6.58 psi	75.00 psi	0.09	OK
+1.20D+L+1.60S+1.60H	18.49 psi	18.49 psi	18.49 psi	18.49 psi	18.49 psi	75.00 psi	0.25	OK
+1.20D+1.60S+0.50W+1.60H	16.52 psi	16.52 psi	16.52 psi	16.52 psi	16.52 psi	75.00 psi	0.22	OK
+1.20D+0.50Lr+L+W+1.60H	8.55 psi	8.55 psi	8.55 psi	8.55 psi	8.55 psi	75.00 psi	0.11	OK
+1.20D+L+0.50S+W+1.60H	11.66 psi	11.66 psi	11.66 psi	11.66 psi	11.66 psi	75.00 psi	0.16	OK
+0.90D+W+1.60H	4.94 psi	4.94 psi	4.94 psi	4.94 psi	4.94 psi	75.00 psi	0.07	OK
+1.20D+L+0.20S+E+1.60H	9.79 psi	9.79 psi	9.79 psi	9.79 psi	9.79 psi	75.00 psi	0.13	OK



Feaster Residence  
 7544 31st Ave NW  
 Seattle, WA 98117  
 Permit # 6736413 - CM

Project Title:  
 Engineer:  
 Project ID:  
 Project Descr:

Printed: 12 JAN 2020, 10:15AM

**General Footing**

File = C:\Users\pasko\Desktop\test.ec6 .  
 Software copyright ENERCALC, INC. 1983-2019, Build:12.19.11.30 .  
 CK Engineering LLC

Lic. # : KW-06009431

**DESCRIPTIO FTNG#3**

**One Way Shear**

Load Combination...	Vu @ -X	Vu @ +X	Vu @ -Z	Vu @ +Z	Vu:Max	Phi Vn	Vu / Phi*Vn	Status
+0.90D+E+0.90H	4.94 psi	4.94 psi	4.94 psi	4.94 psi	4.94 psi	75.00 psi	0.07	<b>OK</b>
<b>Two-Way "Punching" Shear</b>								All units k

Load Combination...	Vu	Phi*Vn	Vu / Phi*Vn	Status
+1.40D+1.60H	30.16 psi	150.00psi	0.201	<b>OK</b>
+1.20D+0.50Lr+1.60L+1.60H	38.23 psi	150.00psi	0.2548	<b>OK</b>
+1.20D+1.60L+0.50S+1.60H	50.42 psi	150.00psi	0.3362	<b>OK</b>
+1.20D+1.60Lr+L+1.60H	33.58 psi	150.00psi	0.2239	<b>OK</b>
+1.20D+1.60Lr+0.50W+1.60H	25.85 psi	150.00psi	0.1723	<b>OK</b>
+1.20D+L+1.60S+1.60H	72.62 psi	150.00psi	0.4841	<b>OK</b>
+1.20D+1.60S+0.50W+1.60H	64.88 psi	150.00psi	0.4326	<b>OK</b>
+1.20D+0.50Lr+L+W+1.60H	33.58 psi	150.00psi	0.2239	<b>OK</b>
+1.20D+L+0.50S+W+1.60H	45.78 psi	150.00psi	0.3052	<b>OK</b>
+0.90D+W+1.60H	19.39 psi	150.00psi	0.1292	<b>OK</b>
+1.20D+L+0.20S+E+1.60H	38.46 psi	150.00psi	0.2564	<b>OK</b>
+0.90D+E+0.90H	19.39 psi	150.00psi	0.1292	<b>OK</b>

**General Footing**

Lic. #: KW-06009431

**DESCRIPTIO FTNG#4**

**Code References**

Calculations per ACI 318-14, IBC 2015, CBC 2016, ASCE 7-10  
 Load Combinations Used : ASCE 7-16

**General Information**

**Material Properties**

f <sub>c</sub> : Concrete 28 day strength	=	2.50	ksi
f <sub>y</sub> : Rebar Yield	=	60.0	ksi
E <sub>c</sub> : Concrete Elastic Modulus	=	3,122.0	ksi
Concrete Density	=	145.0	pcf
φ Values Flexure	=	0.90	
Shear	=	0.750	

**Soil Design Values**

Allowable Soil Beari	=	1.50	ksf
Increase Bearing By Footing Weight	=	No	
Soil Passive Resistance (for Sliding)	=	150.0	pcf
Soil/Concrete Friction Coeff.	=	0.250	

**Analysis Settings**

Min Steel % Bending Reinf.	=		
Min Allow % Temp Reinf.	=	0.00180	
Min. Overturning Safety Factor	=	1.0 : 1	
Min. Sliding Safety Factor	=	1.0 : 1	
Add Ftg Wt for Soil Pressure	:	Yes	
Use ftg wt for stability, moments & shears	:	Yes	
Add Pedestal Wt for Soil Pressure	:	No	
Use Pedestal wt for stability, mom & shear	:	No	

**Increases based on footing Depth**

Footing base depth below soil surface	=	1.0	ft
Allow press. increase per foot of depth when footing base is below	=		ksf ft

**Increases based on footing plan dimension**

Allowable pressure increase per foot of depth when max. length or width is greater than	=		ksf ft
---	---	--	-----------

**Dimensions**

Width parallel to X-X Axis	=	3.0	ft
Length parallel to Z-Z Axis	=	3.0	ft
Footing Thickness	=	14.0	in

**Pedestal dimensions...**

px : parallel to X-X Axis	=		in
pz : parallel to Z-Z Axis	=		in
Height	=		in
Rebar Centerline to Edge of Concrete... at Bottom of footing	=	3.0	in

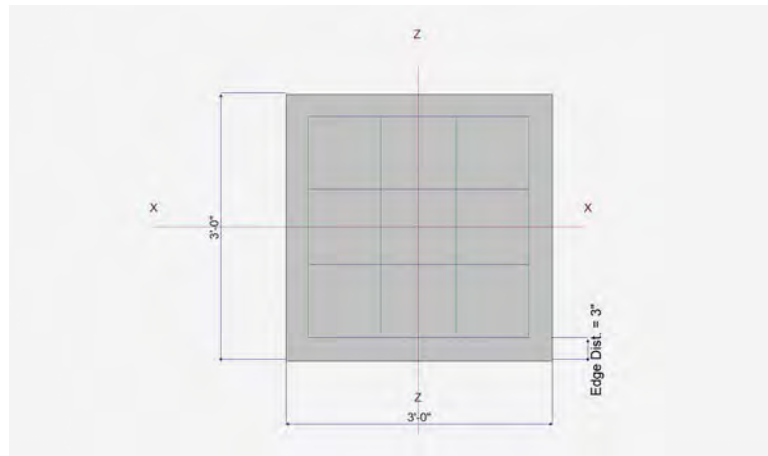

**Reinforcing**

Bars parallel to X-X Axis	=		
Number of Bars	=	4.0	
Reinforcing Bar Size	=	# 5	

Bars parallel to Z-Z Axis	=		
Number of Bars	=	4.0	
Reinforcing Bar Size	=	# 5	

**Bandwidth Distribution Check (ACI 15.4.4.2)**

Direction Requiring Closer Separatio	=	n/a	
# Bars required within zone	=	n/a	
# Bars required on each side of zone	=	n/a	

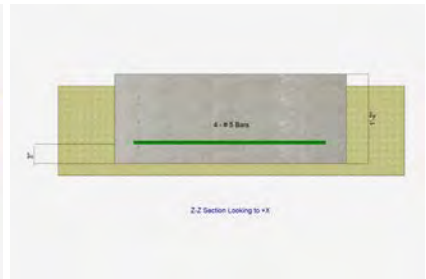
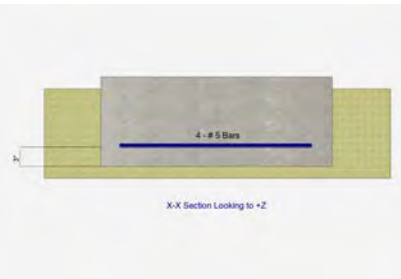

**Applied Loads**

	D	L <sub>r</sub>	L	S	W	E	H	
P : Column Load	=	3.70			8.140			k
OB : Overburden	=							ksf
M-xx	=							k-ft
M-zz	=							k-ft
V-x	=							k
V-z	=							k

**General Footing**

Lic. # : KW-06009431

**DESCRIPTIO FTNG#4**

**DESIGN SUMMARY**

**Design OK**

	Min. Ratio	Item	Applied	Capacity	Governing Load Combination
PASS	0.990	Soil Bearing	1.485 ksf	1.50 ksf	+D+S+H about Z-Z axis
PASS	n/a	Overturing - X-X	0.0 k-ft	0.0 k-ft	No Overturing
PASS	n/a	Overturing - Z-Z	0.0 k-ft	0.0 k-ft	No Overturing
PASS	n/a	Sliding - X-X	0.0 k	0.0 k	No Sliding
PASS	n/a	Sliding - Z-Z	0.0 k	0.0 k	No Sliding
PASS	n/a	Uplift	0.0 k	0.0 k	No Uplift
PASS	0.1116	Z Flexure (+X)	2.183 k-ft/ft	19.556 k-ft/ft	+1.20D+L+1.60S+1.60H
PASS	0.1116	Z Flexure (-X)	2.183 k-ft/ft	19.556 k-ft/ft	+1.20D+L+1.60S+1.60H
PASS	0.1116	X Flexure (+Z)	2.183 k-ft/ft	19.556 k-ft/ft	+1.20D+L+1.60S+1.60H
PASS	0.1116	X Flexure (-Z)	2.183 k-ft/ft	19.556 k-ft/ft	+1.20D+L+1.60S+1.60H
PASS	0.1117	1-way Shear (+X)	8.379 psi	75.0 psi	+1.20D+L+1.60S+1.60H
PASS	0.1117	1-way Shear (-X)	8.379 psi	75.0 psi	+1.20D+L+1.60S+1.60H
PASS	0.1117	1-way Shear (+Z)	8.379 psi	75.0 psi	+1.20D+L+1.60S+1.60H
PASS	0.1117	1-way Shear (-Z)	8.379 psi	75.0 psi	+1.20D+L+1.60S+1.60H
PASS	0.2189	2-way Punching	32.835 psi	150.0 psi	+1.20D+L+1.60S+1.60H

**Detailed Results**

**Soil Bearing**

Rotation Axis & Load Combination...	Gross Allowable	Xecc	Zecc (in)	Actual Soil Bearing Stress @ Location				Actual / Allow Ratio
				Bottom, -Z	Top, +Z	Left, -X	Right, +X	
X-X, +D+H	1.50	n/a	0.0	0.5803	0.5803	n/a	n/a	0.387
X-X, +D+L+H	1.50	n/a	0.0	0.5803	0.5803	n/a	n/a	0.387
X-X, +D+Lr+H	1.50	n/a	0.0	0.5803	0.5803	n/a	n/a	0.387
X-X, +D+S+H	1.50	n/a	0.0	1.485	1.485	n/a	n/a	0.990
X-X, +D+0.750Lr+0.750L+H	1.50	n/a	0.0	0.5803	0.5803	n/a	n/a	0.387
X-X, +D+0.750L+0.750S+H	1.50	n/a	0.0	1.259	1.259	n/a	n/a	0.839
X-X, +D+0.60W+H	1.50	n/a	0.0	0.5803	0.5803	n/a	n/a	0.387
X-X, +D+0.750Lr+0.750L+0.450W	1.50	n/a	0.0	0.5803	0.5803	n/a	n/a	0.387
X-X, +D+0.750L+0.750S+0.450W	1.50	n/a	0.0	1.259	1.259	n/a	n/a	0.839
X-X, +0.60D+0.60W+0.60H	1.50	n/a	0.0	0.3482	0.3482	n/a	n/a	0.232
X-X, +D+0.70E+0.60H	1.50	n/a	0.0	0.5803	0.5803	n/a	n/a	0.387
X-X, +D+0.750L+0.750S+0.5250E	1.50	n/a	0.0	1.259	1.259	n/a	n/a	0.839
X-X, +0.60D+0.70E+H	1.50	n/a	0.0	0.3482	0.3482	n/a	n/a	0.232
Z-Z, +D+H	1.50	0.0	n/a	n/a	n/a	0.5803	0.5803	0.387
Z-Z, +D+L+H	1.50	0.0	n/a	n/a	n/a	0.5803	0.5803	0.387
Z-Z, +D+Lr+H	1.50	0.0	n/a	n/a	n/a	0.5803	0.5803	0.387
Z-Z, +D+S+H	1.50	0.0	n/a	n/a	n/a	1.485	1.485	0.990
Z-Z, +D+0.750Lr+0.750L+H	1.50	0.0	n/a	n/a	n/a	0.5803	0.5803	0.387
Z-Z, +D+0.750L+0.750S+H	1.50	0.0	n/a	n/a	n/a	1.259	1.259	0.839
Z-Z, +D+0.60W+H	1.50	0.0	n/a	n/a	n/a	0.5803	0.5803	0.387
Z-Z, +D+0.750Lr+0.750L+0.450W	1.50	0.0	n/a	n/a	n/a	0.5803	0.5803	0.387
Z-Z, +D+0.750L+0.750S+0.450W	1.50	0.0	n/a	n/a	n/a	1.259	1.259	0.839
Z-Z, +0.60D+0.60W+0.60H	1.50	0.0	n/a	n/a	n/a	0.3482	0.3482	0.232
Z-Z, +D+0.70E+0.60H	1.50	0.0	n/a	n/a	n/a	0.5803	0.5803	0.387
Z-Z, +D+0.750L+0.750S+0.5250E	1.50	0.0	n/a	n/a	n/a	1.259	1.259	0.839
Z-Z, +0.60D+0.70E+H	1.50	0.0	n/a	n/a	n/a	0.3482	0.3482	0.232

**Overturing Stability**

Rotation Axis & Load Combination...	Overturing Moment	Resisting Moment	Stability Ratio	Status
Footing Has NO Overturing				

**Sliding Stability**

All units k

Force Application Axis Load Combination...	Sliding Force	Resisting Force	Stability Ratio	Status
Footing Has NO Sliding				

**General Footing**

**DESCRIPTIO FTNG#4**

**Footing Flexure**

Flexure Axis & Load Combination	Mu k-ft	Side	Tension Surface	As Req'd in^2	Gvrn. As in^2	Actual As in^2	Phi*Mn k-ft	Status
X-X, +1.40D+1.60H	0.6475	+Z	Bottom	0.3024	Min Temp %	0.4133	19.556	OK
X-X, +1.40D+1.60H	0.6475	-Z	Bottom	0.3024	Min Temp %	0.4133	19.556	OK
X-X, +1.20D+0.50Lr+1.60L+1.60H	0.5550	+Z	Bottom	0.3024	Min Temp %	0.4133	19.556	OK
X-X, +1.20D+0.50Lr+1.60L+1.60H	0.5550	-Z	Bottom	0.3024	Min Temp %	0.4133	19.556	OK
X-X, +1.20D+1.60L+0.50S+1.60H	1.064	+Z	Bottom	0.3024	Min Temp %	0.4133	19.556	OK
X-X, +1.20D+1.60L+0.50S+1.60H	1.064	-Z	Bottom	0.3024	Min Temp %	0.4133	19.556	OK
X-X, +1.20D+1.60Lr+L+1.60H	0.5550	+Z	Bottom	0.3024	Min Temp %	0.4133	19.556	OK
X-X, +1.20D+1.60Lr+L+1.60H	0.5550	-Z	Bottom	0.3024	Min Temp %	0.4133	19.556	OK
X-X, +1.20D+1.60Lr+0.50W+1.60	0.5550	+Z	Bottom	0.3024	Min Temp %	0.4133	19.556	OK
X-X, +1.20D+1.60Lr+0.50W+1.60	0.5550	-Z	Bottom	0.3024	Min Temp %	0.4133	19.556	OK
X-X, +1.20D+L+1.60S+1.60H	2.183	+Z	Bottom	0.3024	Min Temp %	0.4133	19.556	OK
X-X, +1.20D+L+1.60S+1.60H	2.183	-Z	Bottom	0.3024	Min Temp %	0.4133	19.556	OK
X-X, +1.20D+1.60S+0.50W+1.60H	2.183	+Z	Bottom	0.3024	Min Temp %	0.4133	19.556	OK
X-X, +1.20D+1.60S+0.50W+1.60H	2.183	-Z	Bottom	0.3024	Min Temp %	0.4133	19.556	OK
X-X, +1.20D+0.50Lr+L+W+1.60H	0.5550	+Z	Bottom	0.3024	Min Temp %	0.4133	19.556	OK
X-X, +1.20D+0.50Lr+L+W+1.60H	0.5550	-Z	Bottom	0.3024	Min Temp %	0.4133	19.556	OK
X-X, +1.20D+L+0.50S+W+1.60H	1.064	+Z	Bottom	0.3024	Min Temp %	0.4133	19.556	OK
X-X, +1.20D+L+0.50S+W+1.60H	1.064	-Z	Bottom	0.3024	Min Temp %	0.4133	19.556	OK
X-X, +0.90D+W+1.60H	0.4163	+Z	Bottom	0.3024	Min Temp %	0.4133	19.556	OK
X-X, +0.90D+W+1.60H	0.4163	-Z	Bottom	0.3024	Min Temp %	0.4133	19.556	OK
X-X, +1.20D+L+0.20S+E+1.60H	0.7585	+Z	Bottom	0.3024	Min Temp %	0.4133	19.556	OK
X-X, +1.20D+L+0.20S+E+1.60H	0.7585	-Z	Bottom	0.3024	Min Temp %	0.4133	19.556	OK
X-X, +0.90D+E+0.90H	0.4163	+Z	Bottom	0.3024	Min Temp %	0.4133	19.556	OK
X-X, +0.90D+E+0.90H	0.4163	-Z	Bottom	0.3024	Min Temp %	0.4133	19.556	OK
Z-Z, +1.40D+1.60H	0.6475	-X	Bottom	0.3024	Min Temp %	0.4133	19.556	OK
Z-Z, +1.40D+1.60H	0.6475	+X	Bottom	0.3024	Min Temp %	0.4133	19.556	OK
Z-Z, +1.20D+0.50Lr+1.60L+1.60H	0.5550	-X	Bottom	0.3024	Min Temp %	0.4133	19.556	OK
Z-Z, +1.20D+0.50Lr+1.60L+1.60H	0.5550	+X	Bottom	0.3024	Min Temp %	0.4133	19.556	OK
Z-Z, +1.20D+1.60L+0.50S+1.60H	1.064	-X	Bottom	0.3024	Min Temp %	0.4133	19.556	OK
Z-Z, +1.20D+1.60L+0.50S+1.60H	1.064	+X	Bottom	0.3024	Min Temp %	0.4133	19.556	OK
Z-Z, +1.20D+1.60Lr+L+1.60H	0.5550	-X	Bottom	0.3024	Min Temp %	0.4133	19.556	OK
Z-Z, +1.20D+1.60Lr+L+1.60H	0.5550	+X	Bottom	0.3024	Min Temp %	0.4133	19.556	OK
Z-Z, +1.20D+1.60Lr+0.50W+1.60	0.5550	-X	Bottom	0.3024	Min Temp %	0.4133	19.556	OK
Z-Z, +1.20D+1.60Lr+0.50W+1.60	0.5550	+X	Bottom	0.3024	Min Temp %	0.4133	19.556	OK
Z-Z, +1.20D+L+1.60S+1.60H	2.183	-X	Bottom	0.3024	Min Temp %	0.4133	19.556	OK
Z-Z, +1.20D+L+1.60S+1.60H	2.183	+X	Bottom	0.3024	Min Temp %	0.4133	19.556	OK
Z-Z, +1.20D+1.60S+0.50W+1.60H	2.183	-X	Bottom	0.3024	Min Temp %	0.4133	19.556	OK
Z-Z, +1.20D+1.60S+0.50W+1.60H	2.183	+X	Bottom	0.3024	Min Temp %	0.4133	19.556	OK
Z-Z, +1.20D+0.50Lr+L+W+1.60H	0.5550	-X	Bottom	0.3024	Min Temp %	0.4133	19.556	OK
Z-Z, +1.20D+0.50Lr+L+W+1.60H	0.5550	+X	Bottom	0.3024	Min Temp %	0.4133	19.556	OK
Z-Z, +1.20D+L+0.50S+W+1.60H	1.064	-X	Bottom	0.3024	Min Temp %	0.4133	19.556	OK
Z-Z, +1.20D+L+0.50S+W+1.60H	1.064	+X	Bottom	0.3024	Min Temp %	0.4133	19.556	OK
Z-Z, +0.90D+W+1.60H	0.4163	-X	Bottom	0.3024	Min Temp %	0.4133	19.556	OK
Z-Z, +0.90D+W+1.60H	0.4163	+X	Bottom	0.3024	Min Temp %	0.4133	19.556	OK
Z-Z, +1.20D+L+0.20S+E+1.60H	0.7585	-X	Bottom	0.3024	Min Temp %	0.4133	19.556	OK
Z-Z, +1.20D+L+0.20S+E+1.60H	0.7585	+X	Bottom	0.3024	Min Temp %	0.4133	19.556	OK
Z-Z, +0.90D+E+0.90H	0.4163	-X	Bottom	0.3024	Min Temp %	0.4133	19.556	OK
Z-Z, +0.90D+E+0.90H	0.4163	+X	Bottom	0.3024	Min Temp %	0.4133	19.556	OK

**One Way Shear**

Load Combination...	Vu @ -X	Vu @ +X	Vu @ -Z	Vu @ +Z	Vu:Max	Phi Vn	Vu / Phi*Vn	Status
+1.40D+1.60H	2.49 psi	2.49 psi	2.49 psi	2.49 psi	2.49 psi	75.00 psi	0.03	OK
+1.20D+0.50Lr+1.60L+1.60H	2.13 psi	2.13 psi	2.13 psi	2.13 psi	2.13 psi	75.00 psi	0.03	OK
+1.20D+1.60L+0.50S+1.60H	4.08 psi	4.08 psi	4.08 psi	4.08 psi	4.08 psi	75.00 psi	0.05	OK
+1.20D+1.60Lr+L+1.60H	2.13 psi	2.13 psi	2.13 psi	2.13 psi	2.13 psi	75.00 psi	0.03	OK
+1.20D+1.60Lr+0.50W+1.60H	2.13 psi	2.13 psi	2.13 psi	2.13 psi	2.13 psi	75.00 psi	0.03	OK
+1.20D+L+1.60S+1.60H	8.38 psi	8.38 psi	8.38 psi	8.38 psi	8.38 psi	75.00 psi	0.11	OK
+1.20D+1.60S+0.50W+1.60H	8.38 psi	8.38 psi	8.38 psi	8.38 psi	8.38 psi	75.00 psi	0.11	OK
+1.20D+0.50Lr+L+W+1.60H	2.13 psi	2.13 psi	2.13 psi	2.13 psi	2.13 psi	75.00 psi	0.03	OK
+1.20D+L+0.50S+W+1.60H	4.08 psi	4.08 psi	4.08 psi	4.08 psi	4.08 psi	75.00 psi	0.05	OK
+0.90D+W+1.60H	1.60 psi	1.60 psi	1.60 psi	1.60 psi	1.60 psi	75.00 psi	0.02	OK
+1.20D+L+0.20S+E+1.60H	2.91 psi	2.91 psi	2.91 psi	2.91 psi	2.91 psi	75.00 psi	0.04	OK

Feaster Residence  
 7544 31st Ave NW  
 Seattle, WA 98117  
 Permit # 6736413 - CM

Project Title:  
 Engineer:  
 Project ID:  
 Project Descr:

Printed: 12 JAN 2020, 10:15AM

**General Footing**

File = C:\Users\pasko\Desktop\test.ec6 .  
 Software copyright ENERCALC, INC. 1983-2019, Build:12.19.11.30 .  
 CK Engineering LLC

Lic. # : KW-06009431

**DESCRIPTIO FTNG#4**

**One Way Shear**

Load Combination...	Vu @ -X	Vu @ +X	Vu @ -Z	Vu @ +Z	Vu:Max	Phi Vn	Vu / Phi*Vn	Status
+0.90D+E+0.90H	1.60 psi	1.60 psi	1.60 psi	1.60 psi	1.60 psi	75.00 psi	0.02	<b>OK</b>
<b>Two-Way "Punching" Shear</b>								All units k

Load Combination...	Vu	Phi*Vn	Vu / Phi*Vn	Status
+1.40D+1.60H	9.74 psi	150.00psi	0.06493	<b>OK</b>
+1.20D+0.50Lr+1.60L+1.60H	8.35 psi	150.00psi	0.05565	<b>OK</b>
+1.20D+1.60L+0.50S+1.60H	16.00 psi	150.00psi	0.1067	<b>OK</b>
+1.20D+1.60Lr+L+1.60H	8.35 psi	150.00psi	0.05565	<b>OK</b>
+1.20D+1.60Lr+0.50W+1.60H	8.35 psi	150.00psi	0.05565	<b>OK</b>
+1.20D+L+1.60S+1.60H	32.84 psi	150.00psi	0.2189	<b>OK</b>
+1.20D+1.60S+0.50W+1.60H	32.84 psi	150.00psi	0.2189	<b>OK</b>
+1.20D+0.50Lr+L+W+1.60H	8.35 psi	150.00psi	0.05565	<b>OK</b>
+1.20D+L+0.50S+W+1.60H	16.00 psi	150.00psi	0.1067	<b>OK</b>
+0.90D+W+1.60H	6.26 psi	150.00psi	0.04174	<b>OK</b>
+1.20D+L+0.20S+E+1.60H	11.41 psi	150.00psi	0.07606	<b>OK</b>
+0.90D+E+0.90H	6.26 psi	150.00psi	0.04174	<b>OK</b>



**General Footing**

Lic. # : KW-06009431

**DESCRIPTIO FTNG#5**

**Code References**

Calculations per ACI 318-14, IBC 2015, CBC 2016, ASCE 7-10  
 Load Combinations Used : ASCE 7-16

**General Information**

**Material Properties**

f <sub>c</sub> : Concrete 28 day strength	=	2.50 ksi
f <sub>y</sub> : Rebar Yield	=	40.0 ksi
E <sub>c</sub> : Concrete Elastic Modulus	=	3,122.0 ksi
Concrete Density	=	145.0 pcf
φ Values Flexure	=	0.90
Shear	=	0.750

**Soil Design Values**

Allowable Soil Beari	=	1.50 ksf
Increase Bearing By Footing Weight	=	No
Soil Passive Resistance (for Sliding)	=	150.0 pcf
Soil/Concrete Friction Coeff.	=	0.250

**Analysis Settings**

Min Steel % Bending Reinf.	=	
Min Allow % Temp Reinf.	=	0.00180
Min. Overturning Safety Factor	=	1.0 : 1
Min. Sliding Safety Factor	=	1.0 : 1
Add Ftg Wt for Soil Pressure	:	Yes
Use ftg wt for stability, moments & shears	:	Yes
Add Pedestal Wt for Soil Pressure	:	No
Use Pedestal wt for stability, mom & shear	:	No

**Increases based on footing Depth**

Footing base depth below soil surface	=	1.0 ft
Allow press. increase per foot of depth when footing base is below	=	ksf ft

**Increases based on footing plan dimension**

Allowable pressure increase per foot of depth when max. length or width is greater than	=	ksf
	=	ft

**Dimensions**

Width parallel to X-X Axis	=	2.0 ft
Length parallel to Z-Z Axis	=	2.0 ft
Footing Thickness	=	10.0 in

**Pedestal dimensions...**

px : parallel to X-X Axis	=	in
pz : parallel to Z-Z Axis	=	in
Height	=	in
Rebar Centerline to Edge of Concrete... at Bottom of footing	=	3.0 in

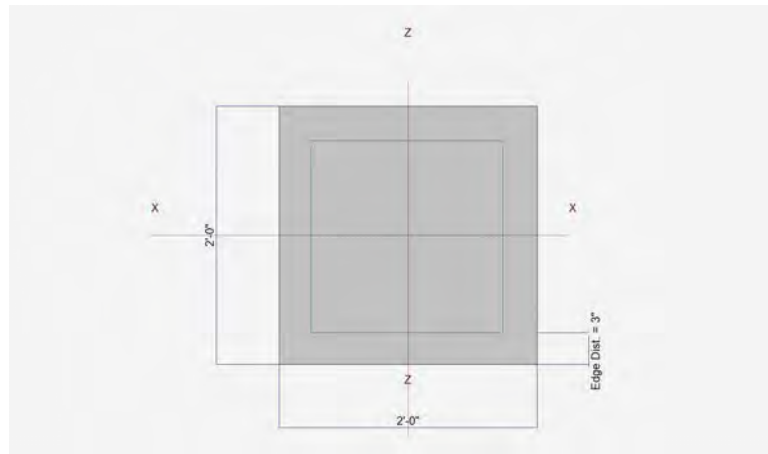

**Reinforcing**

Bars parallel to X-X Axis	=	
Number of Bars	=	3
Reinforcing Bar Size	=	# 4

Bars parallel to Z-Z Axis	=	
Number of Bars	=	3
Reinforcing Bar Size	=	# 4

**Bandwidth Distribution Check (ACI 15.4.4.2)**

Direction Requiring Closer Separatio	=	n/a
# Bars required within zone	=	n/a
# Bars required on each side of zone	=	n/a

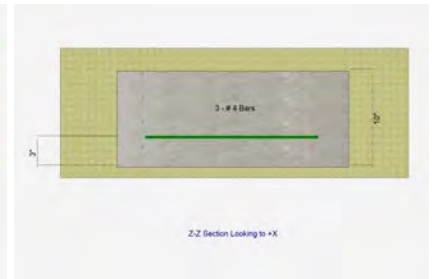

**Applied Loads**

	D	L <sub>r</sub>	L	S	W	E	H
P : Column Load	=	1.30			2.0		k
OB : Overburden	=						ksf
M-xx	=						k-ft
M-zz	=						k-ft
V-x	=						k
V-z	=						k

**General Footing**

Lic. # : KW-06009431

**DESCRIPTIO FTNG#5**

**DESIGN SUMMARY**

**Design OK**

	Min. Ratio	Item	Applied	Capacity	Governing Load Combination
PASS	0.6428	Soil Bearing	0.9642 ksf	1.50 ksf	+D+S+H about Z-Z axis
PASS	n/a	Overturing - X-X	0.0 k-ft	0.0 k-ft	No Overturing
PASS	n/a	Overturing - Z-Z	0.0 k-ft	0.0 k-ft	No Overturing
PASS	n/a	Sliding - X-X	0.0 k	0.0 k	No Sliding
PASS	n/a	Sliding - Z-Z	0.0 k	0.0 k	No Sliding
PASS	n/a	Uplift	0.0 k	0.0 k	No Uplift
PASS	0.09773	Z Flexure (+X)	0.5950 k-ft/ft	6.088 k-ft/ft	+1.20D+L+1.60S+1.60H
PASS	0.09773	Z Flexure (-X)	0.5950 k-ft/ft	6.088 k-ft/ft	+1.20D+L+1.60S+1.60H
PASS	0.09773	X Flexure (+Z)	0.5950 k-ft/ft	6.088 k-ft/ft	+1.20D+L+1.60S+1.60H
PASS	0.09773	X Flexure (-Z)	0.5950 k-ft/ft	6.088 k-ft/ft	+1.20D+L+1.60S+1.60H
PASS	0.07933	1-way Shear (+X)	5.950 psi	75.0 psi	+1.20D+L+1.60S+1.60H
PASS	0.07933	1-way Shear (-X)	5.950 psi	75.0 psi	+1.20D+L+1.60S+1.60H
PASS	0.07933	1-way Shear (+Z)	5.950 psi	75.0 psi	+1.20D+L+1.60S+1.60H
PASS	0.07933	1-way Shear (-Z)	5.950 psi	75.0 psi	+1.20D+L+1.60S+1.60H
PASS	0.1473	2-way Punching	22.10 psi	150.0 psi	+1.20D+L+1.60S+1.60H

**Detailed Results**

**Soil Bearing**

Rotation Axis & Load Combination...	Gross Allowable	Xecc	Zecc (in)	Actual Soil Bearing Stress @ Location				Actual / Allow Ratio
				Bottom, -Z	Top, +Z	Left, -X	Right, +X	
X-X, +D+H	1.50	n/a	0.0	0.4642	0.4642	n/a	n/a	0.310
X-X, +D+L+H	1.50	n/a	0.0	0.4642	0.4642	n/a	n/a	0.310
X-X, +D+Lr+H	1.50	n/a	0.0	0.4642	0.4642	n/a	n/a	0.310
X-X, +D+S+H	1.50	n/a	0.0	0.9642	0.9642	n/a	n/a	0.643
X-X, +D+0.750Lr+0.750L+H	1.50	n/a	0.0	0.4642	0.4642	n/a	n/a	0.310
X-X, +D+0.750L+0.750S+H	1.50	n/a	0.0	0.8392	0.8392	n/a	n/a	0.560
X-X, +D+0.60W+H	1.50	n/a	0.0	0.4642	0.4642	n/a	n/a	0.310
X-X, +D+0.750Lr+0.750L+0.450W	1.50	n/a	0.0	0.4642	0.4642	n/a	n/a	0.310
X-X, +D+0.750L+0.750S+0.450W	1.50	n/a	0.0	0.8392	0.8392	n/a	n/a	0.560
X-X, +0.60D+0.60W+0.60H	1.50	n/a	0.0	0.2785	0.2785	n/a	n/a	0.186
X-X, +D+0.70E+0.60H	1.50	n/a	0.0	0.4642	0.4642	n/a	n/a	0.310
X-X, +D+0.750L+0.750S+0.5250E	1.50	n/a	0.0	0.8392	0.8392	n/a	n/a	0.560
X-X, +0.60D+0.70E+H	1.50	n/a	0.0	0.2785	0.2785	n/a	n/a	0.186
Z-Z, +D+H	1.50	0.0	n/a	n/a	n/a	0.4642	0.4642	0.310
Z-Z, +D+L+H	1.50	0.0	n/a	n/a	n/a	0.4642	0.4642	0.310
Z-Z, +D+Lr+H	1.50	0.0	n/a	n/a	n/a	0.4642	0.4642	0.310
Z-Z, +D+S+H	1.50	0.0	n/a	n/a	n/a	0.9642	0.9642	0.643
Z-Z, +D+0.750Lr+0.750L+H	1.50	0.0	n/a	n/a	n/a	0.4642	0.4642	0.310
Z-Z, +D+0.750L+0.750S+H	1.50	0.0	n/a	n/a	n/a	0.8392	0.8392	0.560
Z-Z, +D+0.60W+H	1.50	0.0	n/a	n/a	n/a	0.4642	0.4642	0.310
Z-Z, +D+0.750Lr+0.750L+0.450W	1.50	0.0	n/a	n/a	n/a	0.4642	0.4642	0.310
Z-Z, +D+0.750L+0.750S+0.450W	1.50	0.0	n/a	n/a	n/a	0.8392	0.8392	0.560
Z-Z, +0.60D+0.60W+0.60H	1.50	0.0	n/a	n/a	n/a	0.2785	0.2785	0.186
Z-Z, +D+0.70E+0.60H	1.50	0.0	n/a	n/a	n/a	0.4642	0.4642	0.310
Z-Z, +D+0.750L+0.750S+0.5250E	1.50	0.0	n/a	n/a	n/a	0.8392	0.8392	0.560
Z-Z, +0.60D+0.70E+H	1.50	0.0	n/a	n/a	n/a	0.2785	0.2785	0.186

**Overturing Stability**

Rotation Axis & Load Combination...	Overturing Moment	Resisting Moment	Stability Ratio	Status
Footing Has NO Overturing				

**Sliding Stability**

All units k

Force Application Axis Load Combination...	Sliding Force	Resisting Force	Stability Ratio	Status
Footing Has NO Sliding				

Feaster Residence  
 7544 31st Ave NW  
 Seattle, WA 98117  
 Permit # 6736413 - CM

Project Title:  
 Engineer:  
 Project ID:  
 Project Descr:

Printed: 12 JAN 2020, 10:15AM

**General Footing**

File = C:\Users\pasko\Desktop\test.ec6 .

Software copyright ENERCALC, INC. 1983-2019, Build:12.19.11.30 .

Lic. # : KW-06009431

CK Engineering LLC

**DESCRIPTIO FTNG#5**

**Footing Flexure**

Flexure Axis & Load Combination	Mu k-ft	Side	Tension Surface	As Req'd in^2	Gvrn. As in^2	Actual As in^2	Phi*Mn k-ft	Status
X-X, +1.40D+1.60H	0.2275	+Z	Bottom	0.2160	Min Temp %	0.30	6.088	OK
X-X, +1.40D+1.60H	0.2275	-Z	Bottom	0.2160	Min Temp %	0.30	6.088	OK
X-X, +1.20D+0.50Lr+1.60L+1.60H	0.1950	+Z	Bottom	0.2160	Min Temp %	0.30	6.088	OK
X-X, +1.20D+0.50Lr+1.60L+1.60H	0.1950	-Z	Bottom	0.2160	Min Temp %	0.30	6.088	OK
X-X, +1.20D+1.60L+0.50S+1.60H	0.320	+Z	Bottom	0.2160	Min Temp %	0.30	6.088	OK
X-X, +1.20D+1.60L+0.50S+1.60H	0.320	-Z	Bottom	0.2160	Min Temp %	0.30	6.088	OK
X-X, +1.20D+1.60Lr+L+1.60H	0.1950	+Z	Bottom	0.2160	Min Temp %	0.30	6.088	OK
X-X, +1.20D+1.60Lr+L+1.60H	0.1950	-Z	Bottom	0.2160	Min Temp %	0.30	6.088	OK
X-X, +1.20D+1.60Lr+0.50W+1.60	0.1950	+Z	Bottom	0.2160	Min Temp %	0.30	6.088	OK
X-X, +1.20D+1.60Lr+0.50W+1.60	0.1950	-Z	Bottom	0.2160	Min Temp %	0.30	6.088	OK
X-X, +1.20D+L+1.60S+1.60H	0.5950	+Z	Bottom	0.2160	Min Temp %	0.30	6.088	OK
X-X, +1.20D+L+1.60S+1.60H	0.5950	-Z	Bottom	0.2160	Min Temp %	0.30	6.088	OK
X-X, +1.20D+1.60S+0.50W+1.60H	0.5950	+Z	Bottom	0.2160	Min Temp %	0.30	6.088	OK
X-X, +1.20D+1.60S+0.50W+1.60H	0.5950	-Z	Bottom	0.2160	Min Temp %	0.30	6.088	OK
X-X, +1.20D+0.50Lr+L+W+1.60H	0.1950	+Z	Bottom	0.2160	Min Temp %	0.30	6.088	OK
X-X, +1.20D+0.50Lr+L+W+1.60H	0.1950	-Z	Bottom	0.2160	Min Temp %	0.30	6.088	OK
X-X, +1.20D+L+0.50S+W+1.60H	0.320	+Z	Bottom	0.2160	Min Temp %	0.30	6.088	OK
X-X, +1.20D+L+0.50S+W+1.60H	0.320	-Z	Bottom	0.2160	Min Temp %	0.30	6.088	OK
X-X, +0.90D+W+1.60H	0.1463	+Z	Bottom	0.2160	Min Temp %	0.30	6.088	OK
X-X, +0.90D+W+1.60H	0.1463	-Z	Bottom	0.2160	Min Temp %	0.30	6.088	OK
X-X, +1.20D+L+0.20S+E+1.60H	0.2450	+Z	Bottom	0.2160	Min Temp %	0.30	6.088	OK
X-X, +1.20D+L+0.20S+E+1.60H	0.2450	-Z	Bottom	0.2160	Min Temp %	0.30	6.088	OK
X-X, +0.90D+E+0.90H	0.1463	+Z	Bottom	0.2160	Min Temp %	0.30	6.088	OK
X-X, +0.90D+E+0.90H	0.1463	-Z	Bottom	0.2160	Min Temp %	0.30	6.088	OK
Z-Z, +1.40D+1.60H	0.2275	-X	Bottom	0.2160	Min Temp %	0.30	6.088	OK
Z-Z, +1.40D+1.60H	0.2275	+X	Bottom	0.2160	Min Temp %	0.30	6.088	OK
Z-Z, +1.20D+0.50Lr+1.60L+1.60H	0.1950	-X	Bottom	0.2160	Min Temp %	0.30	6.088	OK
Z-Z, +1.20D+0.50Lr+1.60L+1.60H	0.1950	+X	Bottom	0.2160	Min Temp %	0.30	6.088	OK
Z-Z, +1.20D+1.60L+0.50S+1.60H	0.320	-X	Bottom	0.2160	Min Temp %	0.30	6.088	OK
Z-Z, +1.20D+1.60L+0.50S+1.60H	0.320	+X	Bottom	0.2160	Min Temp %	0.30	6.088	OK
Z-Z, +1.20D+1.60Lr+L+1.60H	0.1950	-X	Bottom	0.2160	Min Temp %	0.30	6.088	OK
Z-Z, +1.20D+1.60Lr+L+1.60H	0.1950	+X	Bottom	0.2160	Min Temp %	0.30	6.088	OK
Z-Z, +1.20D+1.60Lr+0.50W+1.60	0.1950	-X	Bottom	0.2160	Min Temp %	0.30	6.088	OK
Z-Z, +1.20D+1.60Lr+0.50W+1.60	0.1950	+X	Bottom	0.2160	Min Temp %	0.30	6.088	OK
Z-Z, +1.20D+L+1.60S+1.60H	0.5950	-X	Bottom	0.2160	Min Temp %	0.30	6.088	OK
Z-Z, +1.20D+L+1.60S+1.60H	0.5950	+X	Bottom	0.2160	Min Temp %	0.30	6.088	OK
Z-Z, +1.20D+1.60S+0.50W+1.60H	0.5950	-X	Bottom	0.2160	Min Temp %	0.30	6.088	OK
Z-Z, +1.20D+1.60S+0.50W+1.60H	0.5950	+X	Bottom	0.2160	Min Temp %	0.30	6.088	OK
Z-Z, +1.20D+0.50Lr+L+W+1.60H	0.1950	-X	Bottom	0.2160	Min Temp %	0.30	6.088	OK
Z-Z, +1.20D+0.50Lr+L+W+1.60H	0.1950	+X	Bottom	0.2160	Min Temp %	0.30	6.088	OK
Z-Z, +1.20D+L+0.50S+W+1.60H	0.320	-X	Bottom	0.2160	Min Temp %	0.30	6.088	OK
Z-Z, +1.20D+L+0.50S+W+1.60H	0.320	+X	Bottom	0.2160	Min Temp %	0.30	6.088	OK
Z-Z, +0.90D+W+1.60H	0.1463	-X	Bottom	0.2160	Min Temp %	0.30	6.088	OK
Z-Z, +0.90D+W+1.60H	0.1463	+X	Bottom	0.2160	Min Temp %	0.30	6.088	OK
Z-Z, +1.20D+L+0.20S+E+1.60H	0.2450	-X	Bottom	0.2160	Min Temp %	0.30	6.088	OK
Z-Z, +1.20D+L+0.20S+E+1.60H	0.2450	+X	Bottom	0.2160	Min Temp %	0.30	6.088	OK
Z-Z, +0.90D+E+0.90H	0.1463	-X	Bottom	0.2160	Min Temp %	0.30	6.088	OK
Z-Z, +0.90D+E+0.90H	0.1463	+X	Bottom	0.2160	Min Temp %	0.30	6.088	OK

**One Way Shear**

Load Combination...	Vu @ -X	Vu @ +X	Vu @ -Z	Vu @ +Z	Vu:Max	Phi Vn	Vu / Phi*Vn	Status
+1.40D+1.60H	2.28 psi	2.28 psi	2.28 psi	2.28 psi	2.28 psi	75.00 psi	0.03	OK
+1.20D+0.50Lr+1.60L+1.60H	1.95 psi	1.95 psi	1.95 psi	1.95 psi	1.95 psi	75.00 psi	0.03	OK
+1.20D+1.60L+0.50S+1.60H	3.20 psi	3.20 psi	3.20 psi	3.20 psi	3.20 psi	75.00 psi	0.04	OK
+1.20D+1.60Lr+L+1.60H	1.95 psi	1.95 psi	1.95 psi	1.95 psi	1.95 psi	75.00 psi	0.03	OK
+1.20D+1.60Lr+0.50W+1.60H	1.95 psi	1.95 psi	1.95 psi	1.95 psi	1.95 psi	75.00 psi	0.03	OK
+1.20D+L+1.60S+1.60H	5.95 psi	5.95 psi	5.95 psi	5.95 psi	5.95 psi	75.00 psi	0.08	OK
+1.20D+1.60S+0.50W+1.60H	5.95 psi	5.95 psi	5.95 psi	5.95 psi	5.95 psi	75.00 psi	0.08	OK
+1.20D+0.50Lr+L+W+1.60H	1.95 psi	1.95 psi	1.95 psi	1.95 psi	1.95 psi	75.00 psi	0.03	OK
+1.20D+L+0.50S+W+1.60H	3.20 psi	3.20 psi	3.20 psi	3.20 psi	3.20 psi	75.00 psi	0.04	OK
+0.90D+W+1.60H	1.46 psi	1.46 psi	1.46 psi	1.46 psi	1.46 psi	75.00 psi	0.02	OK
+1.20D+L+0.20S+E+1.60H	2.45 psi	2.45 psi	2.45 psi	2.45 psi	2.45 psi	75.00 psi	0.03	OK

Feaster Residence  
 7544 31st Ave NW  
 Seattle, WA 98117  
 Permit # 6736413 - CM

Project Title:  
 Engineer:  
 Project ID:  
 Project Descr:

Printed: 12 JAN 2020, 10:15AM

**General Footing**

File = C:\Users\pasko\Desktop\test.ec6 .  
 Software copyright ENERCALC, INC. 1983-2019, Build:12.19.11.30 .  
 CK Engineering LLC

Lic. # : KW-06009431

**DESCRIPTIO FTNG#5**

**One Way Shear**

Load Combination...	Vu @ -X	Vu @ +X	Vu @ -Z	Vu @ +Z	Vu:Max	Phi Vn	Vu / Phi*Vn	Status
+0.90D+E+0.90H	1.46 psi	1.46 psi	1.46 psi	1.46 psi	1.46 psi	75.00 psi	0.02	OK
<b>Two-Way "Punching" Shear</b>								All units k

Load Combination...	Vu	Phi*Vn	Vu / Phi*Vn	Status
+1.40D+1.60H	8.45 psi	150.00psi	0.05633	OK
+1.20D+0.50Lr+1.60L+1.60H	7.24 psi	150.00psi	0.04829	OK
+1.20D+1.60L+0.50S+1.60H	11.89 psi	150.00psi	0.07924	OK
+1.20D+1.60Lr+L+1.60H	7.24 psi	150.00psi	0.04829	OK
+1.20D+1.60Lr+0.50W+1.60H	7.24 psi	150.00psi	0.04829	OK
+1.20D+L+1.60S+1.60H	22.10 psi	150.00psi	0.1473	OK
+1.20D+1.60S+0.50W+1.60H	22.10 psi	150.00psi	0.1473	OK
+1.20D+0.50Lr+L+W+1.60H	7.24 psi	150.00psi	0.04829	OK
+1.20D+L+0.50S+W+1.60H	11.89 psi	150.00psi	0.07924	OK
+0.90D+W+1.60H	5.43 psi	150.00psi	0.03621	OK
+1.20D+L+0.20S+E+1.60H	9.10 psi	150.00psi	0.06067	OK
+0.90D+E+0.90H	5.43 psi	150.00psi	0.03621	OK

Level, Main floor joist  
1 piece(s) 11 7/8" TJI @ 230 @ 16" OC

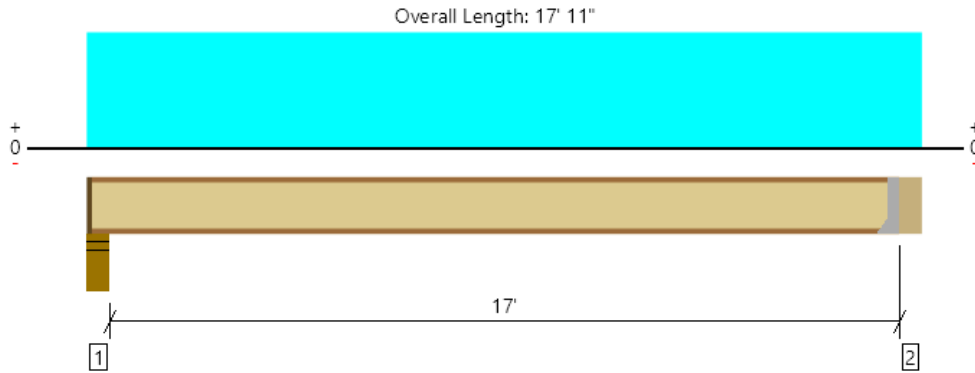

All locations are measured from the outside face of left support (or left cantilever end). All dimensions are horizontal.

Design Results	Actual @ Location	Allowed	Result	LDF	Load: Combination (Pattern)
Member Reaction (lbs)	626 @ 17' 5 1/2"	1060 (1.75")	Passed (59%)	1.00	1.0 D + 1.0 L (All Spans)
Shear (lbs)	626 @ 17' 5 1/2"	1655	Passed (38%)	1.00	1.0 D + 1.0 L (All Spans)
Moment (Ft-lbs)	2675 @ 8' 11"	4215	Passed (63%)	1.00	1.0 D + 1.0 L (All Spans)
Live Load Defl. (in)	0.299 @ 8' 11"	0.427	Passed (L/686)	--	1.0 D + 1.0 L (All Spans)
Total Load Defl. (in)	0.411 @ 8' 11"	0.854	Passed (L/499)	--	1.0 D + 1.0 L (All Spans)
TJ-Pro™ Rating	41	40	Passed	--	--

System : Floor  
Member Type : Joist  
Building Use : Residential  
Building Code : IBC 2015  
Design Methodology : ASD

- Deflection criteria: LL (L/480) and TL (L/240).
- Top Edge Bracing (Lu): Top compression edge must be braced at 5' 2" o/c based on loads applied, unless detailed otherwise.
- Bottom Edge Bracing (Lu): Bottom compression edge must be braced at 17' 4" o/c based on loads applied, unless detailed otherwise.
- A structural analysis of the deck has not been performed.
- Deflection analysis is based on composite action with a single layer of decking\_1932EdgeGold that is nailed Down.
- Additional considerations for the TJ-Pro™ Rating include: 1/2" Gypsum ceiling.

Supports	Bearing Length			Loads to Supports (lbs)			Accessories
	Total	Available	Required	Dead	Floor Live	Total	
1 - Stud wall - SPF	5.50"	4.25"	1.75"	178	476	654	1 1/4" Rim Board
2 - Hanger on 11 7/8" SPF beam	5.50"	Hanger <sup>1</sup>	1.75" / - <sup>2</sup>	180	480	660	See note <sup>1</sup>

- Rim Board is assumed to carry all loads applied directly above it, bypassing the member being designed.
- At hanger supports, the Total Bearing dimension is equal to the width of the material that is supporting the hanger
- <sup>1</sup> See Connector grid below for additional information and/or requirements.
- <sup>2</sup> Required Bearing Length / Required Bearing Length with Web Stiffeners

Connector: Simpson Strong-Tie						
Support	Model	Seat Length	Top Fasteners	Face Fasteners	Member Fasteners	Accessories
2 - Face Mount Hanger	IUS2.37/11.88	2.00"	N/A	10-10d	2-Strong-Grip	

Vertical Load	Location (Side)	Spacing	Dead (0.90)	Floor Live (1.00)	Comments
1 - Uniform (PSF)	0 to 17' 11"	16"	15.0	40.0	Default Load

Member Notes
Upper floor joist

Weyerhaeuser Notes
Weyerhaeuser warrants that the sizing of its products will be in accordance with Weyerhaeuser product design criteria and published design values. Weyerhaeuser expressly disclaims any other warranties related to the software. Use of this software is not intended to circumvent the need for a design professional as determined by the authority having jurisdiction. The designer of record, builder or framer is responsible to assure that this calculation is compatible with the overall project. Accessories (Rim Board, Blocking Panels and Squash Blocks) are not designed by this software. Products manufactured at Weyerhaeuser facilities are third-party certified to sustainable forestry standards. Weyerhaeuser Engineered Lumber Products have been evaluated by ICC-ES under evaluation reports ESR-1153 and ESR-1387 and/or tested in accordance with applicable ASTM standards. For current code evaluation reports, Weyerhaeuser product literature and installation details refer to <a href="http://www.weyerhaeuser.com/woodproducts/document-library">www.weyerhaeuser.com/woodproducts/document-library</a> . The product application, input design loads, dimensions and support information have been provided by ForteWEB Software Operator

ForteWEB Software Operator	Job Notes
Pasko Kesovija CK Engineering LLC (206) 660-5189 pasko@ckengineeringllc.net	





Level, Roof joist, others  
1 piece(s) 14" TJI® 360 @ 16" OC

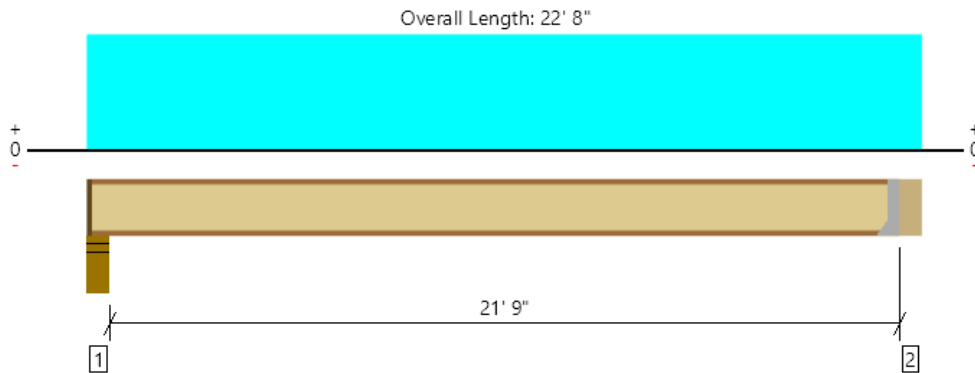

All locations are measured from the outside face of left support (or left cantilever end). All dimensions are horizontal.

Design Results	Actual @ Location	Allowed	Result	LDF	Load: Combination (Pattern)
Member Reaction (lbs)	801 @ 22' 2 1/2"	1080 (1.75")	Passed (74%)	1.00	1.0 D + 1.0 L (All Spans)
Shear (lbs)	801 @ 22' 2 1/2"	1955	Passed (41%)	1.00	1.0 D + 1.0 L (All Spans)
Moment (Ft-lbs)	4370 @ 11' 3 1/2"	7335	Passed (60%)	1.00	1.0 D + 1.0 L (All Spans)
Live Load Defl. (in)	0.455 @ 11' 3 1/2"	0.546	Passed (L/576)	--	1.0 D + 1.0 L (All Spans)
Total Load Defl. (in)	0.626 @ 11' 3 1/2"	1.092	Passed (L/419)	--	1.0 D + 1.0 L (All Spans)
TJ-Pro™ Rating	37	37	Passed	--	--

System : Floor  
Member Type : Joist  
Building Use : Residential  
Building Code : IBC 2015  
Design Methodology : ASD

- Deflection criteria: LL (L/480) and TL (L/240).
- Top Edge Bracing (Lu): Top compression edge must be braced at 4' 10" o/c based on loads applied, unless detailed otherwise.
- Bottom Edge Bracing (Lu): Bottom compression edge must be braced at 22' 1" o/c based on loads applied, unless detailed otherwise.
- A structural analysis of the deck has not been performed.
- Deflection analysis is based on composite action with a single layer of decking\_1932EdgeGold that is nailed Down.
- Additional considerations for the TJ-Pro™ Rating include: 1/2" Gypsum ceiling.

Supports	Bearing Length			Loads to Supports (lbs)			Accessories
	Total	Available	Required	Dead	Floor Live	Total	
1 - Stud wall - SPF	5.50"	4.25"	1.75"	226	602	828	1 1/4" Rim Board
2 - Hanger on 14" SPF beam	5.50"	Hanger <sup>1</sup>	1.75" / - <sup>2</sup>	228	607	835	See note <sup>1</sup>

- Rim Board is assumed to carry all loads applied directly above it, bypassing the member being designed.
- At hanger supports, the Total Bearing dimension is equal to the width of the material that is supporting the hanger
- <sup>1</sup> See Connector grid below for additional information and/or requirements.
- <sup>2</sup> Required Bearing Length / Required Bearing Length with Web Stiffeners

Connector: Simpson Strong-Tie						
Support	Model	Seat Length	Top Fasteners	Face Fasteners	Member Fasteners	Accessories
2 - Face Mount Hanger	IUS2.37/14	2.00"	N/A	12-10d	2-Strong-Grip	

Vertical Load	Location (Side)	Spacing	Dead (0.90)	Floor Live (1.00)	Comments
1 - Uniform (PSF)	0 to 22' 8"	16"	15.0	40.0	Default Load

Member Notes
Upper floor joist

Weyerhaeuser Notes
Weyerhaeuser warrants that the sizing of its products will be in accordance with Weyerhaeuser product design criteria and published design values. Weyerhaeuser expressly disclaims any other warranties related to the software. Use of this software is not intended to circumvent the need for a design professional as determined by the authority having jurisdiction. The designer of record, builder or framer is responsible to assure that this calculation is compatible with the overall project. Accessories (Rim Board, Blocking Panels and Squash Blocks) are not designed by this software. Products manufactured at Weyerhaeuser facilities are third-party certified to sustainable forestry standards. Weyerhaeuser Engineered Lumber Products have been evaluated by ICC-ES under evaluation reports ESR-1153 and ESR-1387 and/or tested in accordance with applicable ASTM standards. For current code evaluation reports, Weyerhaeuser product literature and installation details refer to <a href="http://www.weyerhaeuser.com/woodproducts/document-library">www.weyerhaeuser.com/woodproducts/document-library</a> . The product application, input design loads, dimensions and support information have been provided by ForteWEB Software Operator

ForteWEB Software Operator	Job Notes
Pasko Kesovija CK Engineering LLC (206) 660-5189 pasko@ckengineeringllc.net	



Level, Upper floor joist 2  
1 piece(s) 14" TJI® 230 @ 16" OC

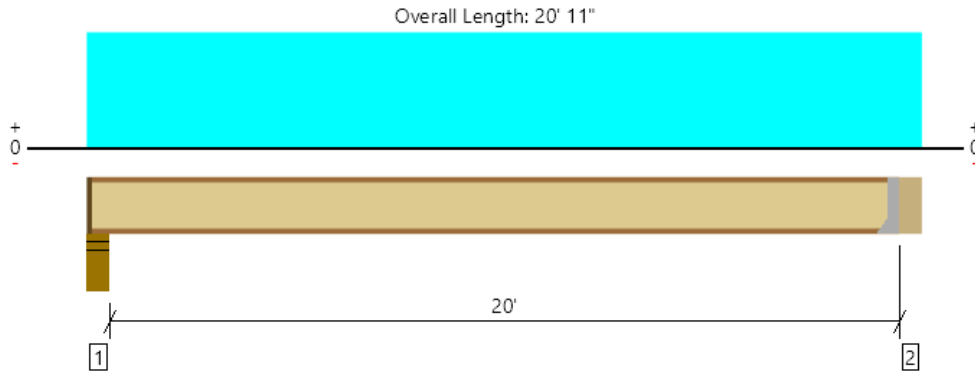

All locations are measured from the outside face of left support (or left cantilever end). All dimensions are horizontal.

Design Results	Actual @ Location	Allowed	Result	LDf	Load: Combination (Pattern)
Member Reaction (lbs)	736 @ 20' 5 1/2"	1060 (1.75")	Passed (69%)	1.00	1.0 D + 1.0 L (All Spans)
Shear (lbs)	736 @ 20' 5 1/2"	1945	Passed (38%)	1.00	1.0 D + 1.0 L (All Spans)
Moment (Ft-lbs)	3697 @ 10' 5"	4990	Passed (74%)	1.00	1.0 D + 1.0 L (All Spans)
Live Load Defl. (in)	0.387 @ 10' 5"	0.502	Passed (L/624)	--	1.0 D + 1.0 L (All Spans)
Total Load Defl. (in)	0.531 @ 10' 5"	1.004	Passed (L/453)	--	1.0 D + 1.0 L (All Spans)
TJ-Pro™ Rating	41	40	Passed	--	--

System : Floor  
Member Type : Joist  
Building Use : Residential  
Building Code : IBC 2015  
Design Methodology : ASD

- Deflection criteria: LL (L/480) and TL (L/240).
- Top Edge Bracing (Lu): Top compression edge must be braced at 4' 9" o/c based on loads applied, unless detailed otherwise.
- Bottom Edge Bracing (Lu): Bottom compression edge must be braced at 20' 4" o/c based on loads applied, unless detailed otherwise.
- A structural analysis of the deck has not been performed.
- Deflection analysis is based on composite action with a single layer of decking\_1932EdgeGold that is nailed Down.
- Additional considerations for the TJ-Pro™ Rating include: 1/2" Gypsum ceiling.

Supports	Bearing Length			Loads to Supports (lbs)			Accessories
	Total	Available	Required	Dead	Floor Live	Total	
1 - Stud wall - SPF	5.50"	4.25"	1.75"	208	556	764	1 1/4" Rim Board
2 - Hanger on 14" SPF beam	5.50"	Hanger <sup>1</sup>	1.75" / - <sup>2</sup>	210	560	770	See note <sup>1</sup>

- Rim Board is assumed to carry all loads applied directly above it, bypassing the member being designed.
- At hanger supports, the Total Bearing dimension is equal to the width of the material that is supporting the hanger
- <sup>1</sup> See Connector grid below for additional information and/or requirements.
- <sup>2</sup> Required Bearing Length / Required Bearing Length with Web Stiffeners

Connector: Simpson Strong-Tie						
Support	Model	Seat Length	Top Fasteners	Face Fasteners	Member Fasteners	Accessories
2 - Face Mount Hanger	IUS2.37/14	2.00"	N/A	12-10d	2-Strong-Grip	

Vertical Load	Location (Side)	Spacing	Dead (0.90)	Floor Live (1.00)	Comments
1 - Uniform (PSF)	0 to 20' 11"	16"	15.0	40.0	Default Load

Member Notes
Upper floor joist

Weyerhaeuser Notes
Weyerhaeuser warrants that the sizing of its products will be in accordance with Weyerhaeuser product design criteria and published design values. Weyerhaeuser expressly disclaims any other warranties related to the software. Use of this software is not intended to circumvent the need for a design professional as determined by the authority having jurisdiction. The designer of record, builder or framer is responsible to assure that this calculation is compatible with the overall project. Accessories (Rim Board, Blocking Panels and Squash Blocks) are not designed by this software. Products manufactured at Weyerhaeuser facilities are third-party certified to sustainable forestry standards. Weyerhaeuser Engineered Lumber Products have been evaluated by ICC-ES under evaluation reports ESR-1153 and ESR-1387 and/or tested in accordance with applicable ASTM standards. For current code evaluation reports, Weyerhaeuser product literature and installation details refer to <a href="http://www.weyerhaeuser.com/woodproducts/document-library">www.weyerhaeuser.com/woodproducts/document-library</a> . The product application, input design loads, dimensions and support information have been provided by ForteWEB Software Operator

ForteWEB Software Operator	Job Notes
Pasko Kesovija CK Engineering LLC (206) 660-5189 pasko@ckengineeringllc.net	



Use menu item Settings > Printing & Title Block  
to set these five lines of information  
for your program.

Project Name/Number : 1500 psf wall

Title :  
Dsgnr: PK  
Description....  
4ft wall

Page : 1  
Date: 13 JUL 2019

This Wall in File: D:\Dropbox\CK PROJECTS\Design\Retaining Walls\1500 psf\1500 psf wall.RPX

RetainPro (c) 1987-2019, Build 11.19.06.12  
License : KW-06059957  
License To : CK Engineering LLC

### Cantilevered Retaining Wall

Code: IBC 2015,ACI 318-14,ACI 530-13

#### Criteria

Retained Height = 4.00 ft  
Wall height above soil = 0.50 ft  
Slope Behind Wall = 0.00  
Height of Soil over Toe = 0.00 in  
Water height over heel = 0.0 ft

#### Soil Data

Allow Soil Bearing = 1,500.0 psf  
Equivalent Fluid Pressure Method  
Active Heel Pressure = 35.0 psf/ft  
  
Passive Pressure = 150.0 psf/ft  
Soil Density, Heel = 110.00 pcf  
Soil Density, Toe = 0.00 pcf  
Footing||Soil Friction = 0.400  
Soil height to ignore  
for passive pressure = 12.00 in

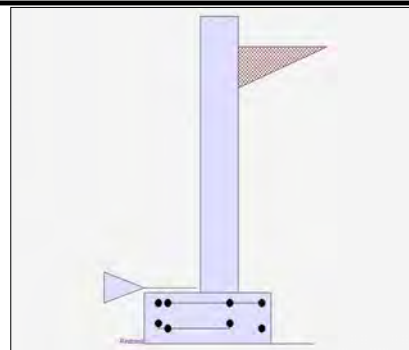

#### Surcharge Loads

Surcharge Over Heel = 0.0 psf  
Used To Resist Sliding & Overturning  
Surcharge Over Toe = 0.0  
Used for Sliding & Overturning

#### Axial Load Applied to Stem

Axial Dead Load = 500.0 lbs  
Axial Live Load = 0.0 lbs  
Axial Load Eccentricity = 0.0 in

#### Earth Pressure Seismic Load

Method : Uniform  
Multiplier Used = 6.000  
(Multiplier used on soil density)

#### Lateral Load Applied to Stem

Lateral Load = 0.0 #/ft  
...Height to Top = 0.00 ft  
...Height to Bottom = 0.00 ft  
Load Type = Wind (W)  
(Service Level)  
Wind on Exposed Stem = 0.0 psf  
(Service Level)

#### Adjacent Footing Load

Adjacent Footing Load = 0.0 lbs  
Footing Width = 0.00 ft  
Eccentricity = 0.00 in  
Wall to Ftg CL Dist = 0.00 ft  
Footing Type = Line Load  
Base Above/Below Soil  
at Back of Wall = 0.0 ft  
Poisson's Ratio = 0.300

#### Stem Weight Seismic Load

$F_p / W_p$  Weight Multiplier = 0.200 g Added seismic base force 63.0 lbs

Use menu item Settings > Printing & Title Block  
to set these five lines of information  
for your program.

Project Name/Number : 1500 psf wall

Title :  
Dsgnr: PK  
Description....  
4ft wall

Page : 2  
Date: 13 JUL 2019

This Wall in File: D:\Dropbox\CK PROJECTS\Design\Retaining Walls\1500 psf\1500 psf wall.RPX

RetainPro (c) 1987-2019, Build 11.19.06.12  
License : KW-06059957  
License To : CK Engineering LLC

## Cantilevered Retaining Wall

Code: IBC 2015,ACI 318-14,ACI 530-13

### Design Summary

#### Wall Stability Ratios

Overturning = 1.91 OK  
Slab Resists All Sliding !

Total Bearing Load = 1,488 lbs  
...resultant ecc. = 5.47 in

Soil Pressure @ Toe = 1,482 psf OK  
Soil Pressure @ Heel = 0 psf OK  
Allowable = 1,500 psf  
Soil Pressure Less Than Allowable

ACI Factored @ Toe = 2,075 psf  
ACI Factored @ Heel = 0 psf  
Footing Shear @ Toe = 8.1 psi OK  
Footing Shear @ Heel = 4.1 psi OK  
Allowable = 75.0 psi

#### Sliding Calcs

Lateral Sliding Force = 569.9 lbs

Vertical component of active lateral soil pressure IS  
NOT considered in the calculation of soil bearing

#### Load Factors

Building Code IBC 2015,ACI  
Dead Load 1.200  
Live Load 1.600  
Earth, H 1.600  
Wind, W 1.000  
Seismic, E 1.000

### Stem Construction

Design Height Above Ftg ft = 0.00  
Wall Material Above "Ht" = Concrete  
Design Method = LRFD  
Thickness = 8.00  
Rebar Size = # 4  
Rebar Spacing = 12.00  
Rebar Placed at = Edge

#### Design Data

fb/FB + fa/Fa = 0.281

#### Total Force @ Section

Service Level lbs =  
Strength Level lbs = 654.0

#### Moment....Actual

Service Level ft-# =  
Strength Level ft-# = 1,031.8

Moment.....Allowable = 3,655.6

#### Shear.....Actual

Service Level psi =  
Strength Level psi = 8.7

Shear.....Allowable psi = 75.0

Anet (Masonry) in2 =

Rebar Depth 'd' in = 6.25

#### Masonry Data

f'm psi =

Fs psi =

Solid Grouting =

Modular Ratio 'n' =

Wall Weight psf = 100.0

Short Term Factor =

Equiv. Solid Thick. =

Masonry Block Type = Medium Weight

Masonry Design Method = ASD

#### Concrete Data

f'c psi = 2,500.0

Fy psi = 40,000.0

### Bottom

Stem OK

Use menu item Settings > Printing & Title Block  
to set these five lines of information  
for your program.

Project Name/Number : 1500 psf wall

Title :  
Dsgnr: PK  
Description....  
4ft wall

Page : 3  
Date: 13 JUL 2019

This Wall in File: D:\Dropbox\CK PROJECTS\Design\Retaining Walls\1500 psf\1500 psf wall.RPX

RetainPro (c) 1987-2019, Build 11.19.06.12  
License : KW-06059957  
License To : CK Engineering LLC

## Cantilevered Retaining Wall

Code: IBC 2015,ACI 318-14,ACI 530-13

### Concrete Stem Rebar Area Details

Bottom Stem	Vertical Reinforcing	Horizontal Reinforcing	
As (based on applied moment) :	0.058 in <sup>2</sup> /ft		
(4/3) * As :	0.0773 in <sup>2</sup> /ft	Min Stem T&S Reinf Area 0.864 in <sup>2</sup>	
200bd/fy : 200(12)(6.25)/40000 :	0.375 in <sup>2</sup> /ft	Min Stem T&S Reinf Area per ft of stem Height : 0.192 in <sup>2</sup> /ft	
0.0018bh : 0.0018(12)(8) :	0.1728 in <sup>2</sup> /ft	Horizontal Reinforcing Options :	
	=====	One layer of :	Two layers of :
Required Area :	0.1728 in <sup>2</sup> /ft	#4@ 12.50 in	#4@ 25.00 in
Provided Area :	0.2 in <sup>2</sup> /ft	#5@ 19.38 in	#5@ 38.75 in
Maximum Area :	1.27 in <sup>2</sup> /ft	#6@ 27.50 in	#6@ 55.00 in

### Footing Data

Toe Width	=	1.00 ft
Heel Width	=	1.25
Total Footing Width	=	2.25
Footing Thickness	=	10.00 in
Key Width	=	12.00 in
Key Depth	=	0.00 in
Key Distance from Toe	=	2.00 ft
f'c =	2,500 psi	Fy = 40,000 psi
Footing Concrete Density	=	150.00 pcf
Min. As %	=	0.0018
Cover @ Top	2.00	@ Btm = 3.00 in

### Footing Design Results

	<u>Toe</u>	<u>Heel</u>
Factored Pressure	= 2,075	0 psf
Mu' : Upward	= 10,384	0 ft-#
Mu' : Downward	= 900	1,384 ft-#
Mu: Design	= 388	115 ft-#
Actual 1-Way Shear	= 8.06	4.12 psi
Allow 1-Way Shear	= 40.00	40.00 psi
Toe Reinforcing	= # 4 @ 16.00 in	
Heel Reinforcing	= # 4 @ 16.00 in	
Key Reinforcing	= None Spec'd	
Footing Torsion, Tu	=	0.00 ft-lbs
Footing Allow. Torsion, phi Tu	=	0.00 ft-lbs

**If torsion exceeds allowable, provide supplemental design for footing torsion.**

#### Other Acceptable Sizes & Spacings

Toe: Not req'd:  $\mu < \phi * 5 * \lambda * \sqrt{f'c} * S_m$   
 Heel: Not req'd:  $\mu < \phi * 5 * \lambda * \sqrt{f'c} * S_m$   
 Key: No key defined

Min footing T&S reinf Area	0.49	in <sup>2</sup>
Min footing T&S reinf Area per foot	0.22	in <sup>2</sup> /ft
If one layer of horizontal bars:	If two layers of horizontal bars:	
#4@ 11.11 in	#4@ 22.22 in	
#5@ 17.22 in	#5@ 34.44 in	
#6@ 24.44 in	#6@ 48.89 in	



Use menu item Settings > Printing & Title Block  
to set these five lines of information  
for your program.

Project Name/Number : 1500 psf wall

Title :  
Dsgnr: PK  
Description....  
4ft wall

Page : 4  
Date: 13 JUL 2019

This Wall in File: D:\Dropbox\CK PROJECTS\Design\Retaining Walls\1500 psf\1500 psf wall.RPX

RetainPro (c) 1987-2019, Build 11.19.06.12  
License : KW-06059957  
License To : CK Engineering LLC

## Cantilevered Retaining Wall

Code: IBC 2015,ACI 318-14,ACI 530-13

### Summary of Overturning & Resisting Forces & Moments

Item	.....OVERTURNING.....				.....RESISTING.....		
	Force lbs	Distance ft	Moment ft-#		Force lbs	Distance ft	Moment ft-#
HL Act Pres (ab water tbl)	408.8	1.61	658.7	Soil Over HL (ab. water tbl)	256.7	1.96	502.6
HL Act Pres (be water tbl)				Soil Over HL (bel. water tbl)		1.96	502.6
Hydrostatic Force				Watre Table			
Buoyant Force =				Sloped Soil Over Heel =			
Surcharge over Heel =				Surcharge Over Heel =			
Surcharge Over Toe =				Adjacent Footing Load =			
Adjacent Footing Load =				Axial Dead Load on Stem =	500.0	1.33	666.7
Added Lateral Load =				* Axial Live Load on Stem =			
Load @ Stem Above Soil =				Soil Over Toe =			
Seismic Earth Load =	98.1	2.42	237.1	Surcharge Over Toe =			
Seismic Stem Self Wt =	63.0	3.08	194.3	Stem Weight(s) =	450.0	1.33	600.0
<b>Total</b> =	<b>569.9</b>	<b>O.T.M. =</b>	<b>1,090.0</b>	Earth @ Stem Transitions =			
				Footing Weight =	281.3	1.13	316.4
				Key Weight =		2.50	
				Vert. Component =			
<b>Resisting/Overturning Ratio</b> =			<b>1.91</b>	<b>Total =</b>	<b>1,487.9 lbs</b>	<b>R.M.=</b>	<b>2,085.7</b>
Vertical Loads used for Soil Pressure =		1,487.9 lbs					

\* Axial live load NOT included in total displayed, or used for overturning resistance, but is included for soil pressure calculation.

If seismic is included, the OTM and sliding ratios be 1.1 per section 1807.2.3 of IBC 2009 or IBC 201

Vertical component of active lateral soil pressure IS NOT considered in the calculation of Sliding Resistance.

Vertical component of active lateral soil pressure IS NOT considered in the calculation of Overturning Resistance.

### Tilt

#### Horizontal Deflection at Top of Wall due to settlement of soil

(Deflection due to wall bending not considered)

Soil Spring Reaction Modulus 250.0 pci  
Horizontal Defl @ Top of Wall (approximate only) 0.000 in

The above calculation is not valid if the heel soil bearing pressure exceeds that of the toe, because the wall would then tend to rotate into the retained soil.

Use menu item Settings > Printing & Title Block  
to set these five lines of information  
for your program.

Project Name/Number : 1500 psf wall

Title :  
Dsgnr: PK  
Description....  
6ft wall

Page : 1  
Date: 13 JUL 2019

This Wall in File: D:\Dropbox\CK PROJECTS\Design\Retaining Walls\1500 psf\1500 psf wall.RPX

RetainPro (c) 1987-2019, Build 11.19.06.12  
License : KW-06059957  
License To : CK Engineering LLC

### Cantilevered Retaining Wall

Code: IBC 2015,ACI 318-14,ACI 530-13

#### Criteria

Retained Height = 6.00 ft  
Wall height above soil = 0.50 ft  
Slope Behind Wall = 0.00  
Height of Soil over Toe = 0.00 in  
Water height over heel = 0.0 ft

#### Soil Data

Allow Soil Bearing = 1,500.0 psf  
Equivalent Fluid Pressure Method  
Active Heel Pressure = 35.0 psf/ft  
  
Passive Pressure = 150.0 psf/ft  
Soil Density, Heel = 110.00 pcf  
Soil Density, Toe = 0.00 pcf  
Footing||Soil Friction = 0.400  
Soil height to ignore  
for passive pressure = 12.00 in

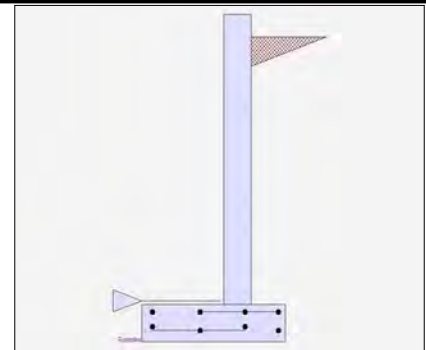

#### Surcharge Loads

Surcharge Over Heel = 0.0 psf  
Used To Resist Sliding & Overturning  
Surcharge Over Toe = 0.0  
Used for Sliding & Overturning

#### Lateral Load Applied to Stem

Lateral Load = 0.0 #/ft  
...Height to Top = 0.00 ft  
...Height to Bottom = 0.00 ft  
Load Type = Wind (W)  
(Service Level)  
Wind on Exposed Stem = 0.0 psf  
(Service Level)

#### Adjacent Footing Load

Adjacent Footing Load = 0.0 lbs  
Footing Width = 0.00 ft  
Eccentricity = 0.00 in  
Wall to Ftg CL Dist = 0.00 ft  
Footing Type = Line Load  
Base Above/Below Soil = 0.0 ft  
at Back of Wall  
Poisson's Ratio = 0.300

#### Axial Load Applied to Stem

Axial Dead Load = 500.0 lbs  
Axial Live Load = 0.0 lbs  
Axial Load Eccentricity = 0.0 in

#### Earth Pressure Seismic Load

Method : Uniform  
Multiplier Used = 6.000  
(Multiplier used on soil density)  
Uniform Seismic Force = 41.000  
Total Seismic Force = 280.167

#### Stem Weight Seismic Load

$F_p / W_p$  Weight Multiplier = 0.200 g Added seismic base force 91.0 lbs

Use menu item Settings > Printing & Title Block  
to set these five lines of information  
for your program.

Project Name/Number : 1500 psf wall

Title :  
Dsgnr: PK  
Description....  
6ft wall

Page : 2  
Date: 13 JUL 2019

This Wall in File: D:\Dropbox\CK PROJECTS\Design\Retaining Walls\1500 psf\1500 psf wall.RPX

RetainPro (c) 1987-2019, Build 11.19.06.12  
License : KW-06059957  
License To : CK Engineering LLC

## Cantilevered Retaining Wall

Code: IBC 2015,ACI 318-14,ACI 530-13

### Design Summary

#### Wall Stability Ratios

Overturning = 1.77 OK  
Slab Resists All Sliding !

Total Bearing Load = 2,138 lbs  
...resultant ecc. = 8.41 in

Soil Pressure @ Toe = 1,359 psf OK  
Soil Pressure @ Heel = 0 psf OK  
Allowable = 1,500 psf  
Soil Pressure Less Than Allowable

ACI Factored @ Toe = 1,902 psf  
ACI Factored @ Heel = 0 psf  
Footing Shear @ Toe = 24.5 psi OK  
Footing Shear @ Heel = 7.5 psi OK  
Allowable = 75.0 psi

#### Sliding Calcs

Lateral Sliding Force = 1,104.3 lbs

Vertical component of active lateral soil pressure IS  
NOT considered in the calculation of soil bearing

#### Load Factors

Building Code IBC 2015,ACI  
Dead Load 1.200  
Live Load 1.600  
Earth, H 1.600  
Wind, W 1.000  
Seismic, E 1.000

### Stem Construction

Design Height Above Ftg ft = 0.00  
Wall Material Above "Ht" = Concrete  
Design Method = LRFD  
Thickness = 8.00  
Rebar Size = # 4  
Rebar Spacing = 10.00  
Rebar Placed at = Edge

#### Design Data

fb/FB + fa/Fa = 0.727

#### Total Force @ Section

Service Level lbs =  
Strength Level lbs = 1,384.0

#### Moment....Actual

Service Level ft-# =  
Strength Level ft-# = 3,176.5

Moment.....Allowable = 4,364.1

#### Shear.....Actual

Service Level psi =  
Strength Level psi = 18.5

Shear.....Allowable psi = 75.0

Anet (Masonry) in2 =

Rebar Depth 'd' in = 6.25

#### Masonry Data

f'm psi =

Fs psi =

Solid Grouting =

Modular Ratio 'n' =

Wall Weight psf = 100.0

Short Term Factor =

Equiv. Solid Thick. =

Masonry Block Type = Medium Weight

Masonry Design Method = ASD

#### Concrete Data

f'c psi = 2,500.0

Fy psi = 40,000.0

### Bottom

Stem OK

Use menu item Settings > Printing & Title Block  
to set these five lines of information  
for your program.

Project Name/Number : 1500 psf wall

Title :  
Dsgnr: PK  
Description....  
6ft wall

Page : 3  
Date: 13 JUL 2019

This Wall in File: D:\Dropbox\CK PROJECTS\Design\Retaining Walls\1500 psf\1500 psf wall.RPX

RetainPro (c) 1987-2019, Build 11.19.06.12  
License : KW-06059957  
License To : CK Engineering LLC

## Cantilevered Retaining Wall

Code: IBC 2015,ACI 318-14,ACI 530-13

### Concrete Stem Rebar Area Details

Bottom Stem	Vertical Reinforcing	Horizontal Reinforcing	
As (based on applied moment) :	0.1785 in2/ft		
(4/3) * As :	0.238 in2/ft	Min Stem T&S Reinf Area 1.248 in2	
200bd/fy : 200(12)(6.25)/40000 :	0.375 in2/ft	Min Stem T&S Reinf Area per ft of stem Height : 0.192 in2/ft	
0.0018bh : 0.0018(12)(8) :	0.1728 in2/ft	Horizontal Reinforcing Options :	
	=====	One layer of :	Two layers of :
Required Area :	0.238 in2/ft	#4@ 12.50 in	#4@ 25.00 in
Provided Area :	0.24 in2/ft	#5@ 19.38 in	#5@ 38.75 in
Maximum Area :	1.27 in2/ft	#6@ 27.50 in	#6@ 55.00 in

### Footing Data

Toe Width	=	2.00 ft
Heel Width	=	1.50
Total Footing Width	=	3.50
Footing Thickness	=	10.00 in
Key Width	=	12.00 in
Key Depth	=	0.00 in
Key Distance from Toe	=	2.00 ft
f'c =	2,500 psi	Fy = 40,000 psi
Footing Concrete Density	=	150.00 pcf
Min. As %	=	0.0018
Cover @ Top	2.00	@ Btm= 3.00 in

### Footing Design Results

	<u>Toe</u>	<u>Heel</u>
Factored Pressure	= 1,902	0 psf
Mu' : Upward	= 35,979	134 ft-#
Mu' : Downward	= 3,600	3,925 ft-#
Mu: Design	= 1,410	30 ft-#
Actual 1-Way Shear	= 24.52	7.45 psi
Allow 1-Way Shear	= 75.00	40.00 psi
Toe Reinforcing	= # 4 @ 11.11 in	
Heel Reinforcing	= # 4 @ 18.00 in	
Key Reinforcing	= None Spec'd	
Footing Torsion, Tu	=	0.00 ft-lbs
Footing Allow. Torsion, phi Tu	=	0.00 ft-lbs

**If torsion exceeds allowable, provide supplemental design for footing torsion.**

#### Other Acceptable Sizes & Spacings

Toe: Not req'd:  $\mu < \phi * 5 * \lambda * \sqrt{f'c} * S_m$   
 Heel: Not req'd:  $\mu < \phi * 5 * \lambda * \sqrt{f'c} * S_m$   
 Key: No key defined

Min footing T&S reinf Area	0.76	in2
Min footing T&S reinf Area per foot	0.22	in2 /ft
If one layer of horizontal bars:	If two layers of horizontal bars:	
#4@ 11.11 in	#4@ 22.22 in	
#5@ 17.22 in	#5@ 34.44 in	
#6@ 24.44 in	#6@ 48.89 in	

Use menu item Settings > Printing & Title Block  
to set these five lines of information  
for your program.

Project Name/Number : 1500 psf wall

Title :  
Dsgnr: PK  
Description....  
6ft wall

Page : 4  
Date: 13 JUL 2019

This Wall in File: D:\Dropbox\CK PROJECTS\Design\Retaining Walls\1500 psf\1500 psf wall.RPX

RetainPro (c) 1987-2019, Build 11.19.06.12  
License : KW-06059957  
License To : CK Engineering LLC

## Cantilevered Retaining Wall

Code: IBC 2015,ACI 318-14,ACI 530-13

### Summary of Overturning & Resisting Forces & Moments

Item	.....OVERTURNING.....			.....RESISTING.....			
	Force lbs	Distance ft	Moment ft-#	Force lbs	Distance ft	Moment ft-#	
HL Act Pres (ab water tbl)	817.2	2.28	1,861.3	Soil Over HL (ab. water tbl)	550.0	3.08	1,695.8
HL Act Pres (be water tbl)				Soil Over HL (bel. water tbl)		3.08	1,695.8
Hydrostatic Force				Watre Table			
Buoyant Force =				Sloped Soil Over Heel =			
Surcharge over Heel =				Surcharge Over Heel =			
Surcharge Over Toe =				Adjacent Footing Load =			
Adjacent Footing Load =				Axial Dead Load on Stem =	500.0	2.33	1,166.7
Added Lateral Load =				* Axial Live Load on Stem =			
Load @ Stem Above Soil =				Soil Over Toe =			
Seismic Earth Load =	196.1	3.42	670.1	Surcharge Over Toe =			
Seismic Stem Self Wt =	91.0	4.08	371.6	Stem Weight(s) =	650.0	2.33	1,516.7
<b>Total</b> =	<b>1,104.3</b>	<b>O.T.M. =</b>	<b>2,902.9</b>	Earth @ Stem Transitions =			
				Footing Weight =	437.5	1.75	765.6
				Key Weight =		2.50	
				Vert. Component =			
<b>Resisting/Overturning Ratio</b> =			<b>1.77</b>	<b>Total =</b>	<b>2,137.5 lbs</b>	<b>R.M.=</b>	<b>5,144.8</b>
Vertical Loads used for Soil Pressure =		2,137.5 lbs					

\* Axial live load NOT included in total displayed, or used for overturning resistance, but is included for soil pressure calculation.

If seismic is included, the OTM and sliding ratios be 1.1 per section 1807.2.3 of IBC 2009 or IBC 201

Vertical component of active lateral soil pressure IS NOT considered in the calculation of Sliding Resistance.

Vertical component of active lateral soil pressure IS NOT considered in the calculation of Overturning Resistance.

### Tilt

#### Horizontal Deflection at Top of Wall due to settlement of soil

(Deflection due to wall bending not considered)

Soil Spring Reaction Modulus 250.0 pci  
Horizontal Defl @ Top of Wall (approximate only) 0.000 in

The above calculation is not valid if the heel soil bearing pressure exceeds that of the toe, because the wall would then tend to rotate into the retained soil.



Use menu item Settings > Printing & Title Block  
to set these five lines of information  
for your program.

Project Name/Number : 1500 psf wall

Title :  
Dsgnr: PK  
Description....  
8ft wall

Page : 1  
Date: 13 JUL 2019

This Wall in File: D:\Dropbox\CK PROJECTS\Design\Retaining Walls\1500 psf\1500 psf wall.RPX

RetainPro (c) 1987-2019, Build 11.19.06.12  
License : KW-06059957  
License To : CK Engineering LLC

### Cantilevered Retaining Wall

Code: IBC 2015,ACI 318-14,ACI 530-13

#### Criteria

Retained Height = 8.00 ft  
Wall height above soil = 0.50 ft  
Slope Behind Wall = 0.00  
Height of Soil over Toe = 0.00 in  
Water height over heel = 0.0 ft

#### Soil Data

Allow Soil Bearing = 1,500.0 psf  
Equivalent Fluid Pressure Method  
Active Heel Pressure = 35.0 psf/ft  
  
Passive Pressure = 150.0 psf/ft  
Soil Density, Heel = 110.00 pcf  
Soil Density, Toe = 0.00 pcf  
Footing||Soil Friction = 0.400  
Soil height to ignore  
for passive pressure = 12.00 in

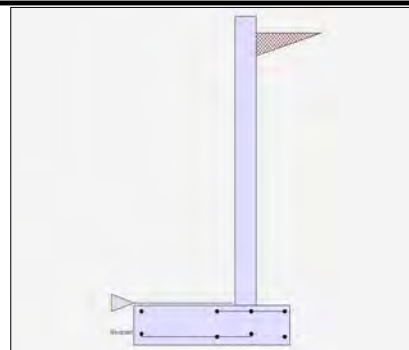

#### Surcharge Loads

Surcharge Over Heel = 0.0 psf  
Used To Resist Sliding & Overturning  
Surcharge Over Toe = 0.0  
Used for Sliding & Overturning

#### Lateral Load Applied to Stem

Lateral Load = 0.0 #/ft  
...Height to Top = 0.00 ft  
...Height to Bottom = 0.00 ft  
Load Type = Wind (W)  
(Service Level)  
Wind on Exposed Stem = 0.0 psf  
(Service Level)

#### Adjacent Footing Load

Adjacent Footing Load = 0.0 lbs  
Footing Width = 0.00 ft  
Eccentricity = 0.00 in  
Wall to Ftg CL Dist = 0.00 ft  
Footing Type = Line Load  
Base Above/Below Soil  
at Back of Wall = 0.0 ft  
Poisson's Ratio = 0.300

#### Axial Load Applied to Stem

Axial Dead Load = 500.0 lbs  
Axial Live Load = 0.0 lbs  
Axial Load Eccentricity = 0.0 in

#### Earth Pressure Seismic Load

Method : Uniform  
Multiplier Used = 6.000  
(Multiplier used on soil density)  
Uniform Seismic Force = 55.000  
Total Seismic Force = 504.167

#### Stem Weight Seismic Load

$F_p / W_p$  Weight Multiplier = 0.200 g Added seismic base force 119.0 lbs

Use menu item **Settings > Printing & Title Block**  
to set these five lines of information  
for your program.

Project Name/Number : 1500 psf wall

Title :  
Dsgnr: PK  
Description...  
8ft wall

Page : 2  
Date: 13 JUL 2019

This Wall in File: D:\Dropbox\CK PROJECTS\Design\Retaining Walls\1500 psf\1500 psf wall.RPX

RetainPro (c) 1987-2019, Build 11.19.06.12  
License : KW-06059957  
License To : CK Engineering LLC

## Cantilevered Retaining Wall

Code: IBC 2015,ACI 318-14,ACI 530-13

### Design Summary

#### Wall Stability Ratios

Overturning = 1.67 OK  
Slab Resists All Sliding !

Total Bearing Load = 3,178 lbs  
...resultant ecc. = 12.93 in

Soil Pressure @ Toe = 1,490 psf OK  
Soil Pressure @ Heel = 0 psf OK  
Allowable = 1,500 psf  
Soil Pressure Less Than Allowable

ACI Factored @ Toe = 2,086 psf  
ACI Factored @ Heel = 0 psf  
Footing Shear @ Toe = 24.4 psi OK  
Footing Shear @ Heel = 9.3 psi OK  
Allowable = 75.0 psi

#### Sliding Calcs

Lateral Sliding Force = 1,942.4 lbs

Vertical component of active lateral soil pressure IS  
NOT considered in the calculation of soil bearing

#### Load Factors

Building Code IBC 2015,ACI  
Dead Load 1.200  
Live Load 1.600  
Earth, H 1.600  
Wind, W 1.000  
Seismic, E 1.000

### Stem Construction

Design Height Above Ftg ft = 0.00  
Wall Material Above "Ht" = Concrete  
Design Method = LRFD  
Thickness = 8.00  
Rebar Size = # 5  
Rebar Spacing = 12.00  
Rebar Placed at = Edge

#### Design Data

fb/FB + fa/Fa = 0.893

#### Total Force @ Section

Service Level lbs =  
Strength Level lbs = 2,402.0

#### Moment....Actual

Service Level ft-# =  
Strength Level ft-# = 7,261.2

Moment....Allowable = 8,121.3

#### Shear.....Actual

Service Level psi =  
Strength Level psi = 32.4

Shear.....Allowable psi = 75.0

Anet (Masonry) in2 =

Rebar Depth 'd' in = 6.19

#### Masonry Data

f'm psi =

Fs psi =

Solid Grouting =

Modular Ratio 'n' =

Wall Weight psf = 100.0

Short Term Factor =

Equiv. Solid Thick. =

Masonry Block Type = Medium Weight

Masonry Design Method = ASD

#### Concrete Data

f'c psi = 2,500.0

Fy psi = 60,000.0

### Bottom

Stem OK

Use menu item Settings > Printing & Title Block  
to set these five lines of information  
for your program.

Project Name/Number : 1500 psf wall

Title :  
Dsgnr: PK  
Description....  
8ft wall

Page : 3  
Date: 13 JUL 2019

This Wall in File: D:\Dropbox\CK PROJECTS\Design\Retaining Walls\1500 psf\1500 psf wall.RPX

RetainPro (c) 1987-2019, Build 11.19.06.12  
License : KW-06059957  
License To : CK Engineering LLC

## Cantilevered Retaining Wall

Code: IBC 2015,ACI 318-14,ACI 530-13

### Concrete Stem Rebar Area Details

Bottom Stem	Vertical Reinforcing	Horizontal Reinforcing	
As (based on applied moment) :	0.2749 in <sup>2</sup> /ft		
(4/3) * As :	0.3666 in <sup>2</sup> /ft	Min Stem T&S Reinf Area 1.632 in <sup>2</sup>	
200bd/fy : 200(12)(6.1875)/60000 :	0.2475 in <sup>2</sup> /ft	Min Stem T&S Reinf Area per ft of stem Height : 0.192 in <sup>2</sup> /ft	
0.0018bh : 0.0018(12)(8) :	0.1728 in <sup>2</sup> /ft	Horizontal Reinforcing Options :	
	=====	One layer of :	Two layers of :
Required Area :	0.2749 in <sup>2</sup> /ft	#4@ 12.50 in	#4@ 25.00 in
Provided Area :	0.31 in <sup>2</sup> /ft	#5@ 19.38 in	#5@ 38.75 in
Maximum Area :	0.8382 in <sup>2</sup> /ft	#6@ 27.50 in	#6@ 55.00 in

### Footing Data

Toe Width	=	3.25 ft
Heel Width	=	1.75
Total Footing Width	=	5.00
Footing Thickness	=	14.00 in
Key Width	=	12.00 in
Key Depth	=	0.00 in
Key Distance from Toe	=	2.00 ft
f'c =	2,500 psi	Fy = 60,000 psi
Footing Concrete Density	=	150.00 pcf
Min. As %	=	0.0018
Cover @ Top	2.00	@ Btm.= 3.00 in

### Footing Design Results

	<u>Toe</u>	<u>Heel</u>
Factored Pressure	= 2,086	0 psf
Mu' : Upward	= 98,628	42 ft-#
Mu' : Downward	= 13,309	8,915 ft-#
Mu: Design	= 3,591	221 ft-#
Actual 1-Way Shear	= 24.42	9.32 psi
Allow 1-Way Shear	= 75.00	40.00 psi
Toe Reinforcing	= # 5 @ 12.30 in	
Heel Reinforcing	= # 5 @ 18.00 in	
Key Reinforcing	= None Spec'd	
Footing Torsion, Tu	=	0.00 ft-lbs
Footing Allow. Torsion, phi Tu	=	0.00 ft-lbs

**If torsion exceeds allowable, provide supplemental design for footing torsion.**

#### Other Acceptable Sizes & Spacings

Toe: Not req'd:  $\mu < \phi * 5 * \lambda * \sqrt{f'c} * S_m$   
 Heel: Not req'd:  $\mu < \phi * 5 * \lambda * \sqrt{f'c} * S_m$   
 Key: No key defined

Min footing T&S reinf Area	1.51	in <sup>2</sup>
Min footing T&S reinf Area per foot	0.30	in <sup>2</sup> /ft
If one layer of horizontal bars:	If two layers of horizontal bars:	
#4@ 7.94 in	#4@ 15.87 in	
#5@ 12.30 in	#5@ 24.60 in	
#6@ 17.46 in	#6@ 34.92 in	

Use menu item Settings > Printing & Title Block  
to set these five lines of information  
for your program.

Project Name/Number : 1500 psf wall

Title :  
Dsgnr: PK  
Description....  
8ft wall

Page : 4  
Date: 13 JUL 2019

This Wall in File: D:\Dropbox\CK PROJECTS\Design\Retaining Walls\1500 psf\1500 psf wall.RPX

RetainPro (c) 1987-2019, Build 11.19.06.12  
License : KW-06059957  
License To : CK Engineering LLC

## Cantilevered Retaining Wall

Code: IBC 2015,ACI 318-14,ACI 530-13

### Summary of Overturning & Resisting Forces & Moments

Item	.....OVERTURNING.....				.....RESISTING.....		
	Force lbs	Distance ft	Moment ft-#		Force lbs	Distance ft	Moment ft-#
HL Act Pres (ab water tbl)	1,470.5	3.06	4,493.2	Soil Over HL (ab. water tbl)	953.3	4.46	4,250.3
HL Act Pres (be water tbl)				Soil Over HL (bel. water tbl)		4.46	4,250.3
Hydrostatic Force				Watre Table			
Buoyant Force =				Sloped Soil Over Heel =			
Surcharge over Heel =				Surcharge Over Heel =			
Surcharge Over Toe =				Adjacent Footing Load =			
Adjacent Footing Load =				Axial Dead Load on Stem =	500.0	3.58	1,791.7
Added Lateral Load =				* Axial Live Load on Stem =			
Load @ Stem Above Soil =				Soil Over Toe =			
Seismic Earth Load =	352.9	4.58	1,617.5	Surcharge Over Toe =			
Seismic Stem Self Wt =	119.0	5.42	644.6	Stem Weight(s) =	850.0	3.58	3,045.8
<b>Total</b> =	<b>1,942.4</b>	<b>O.T.M. =</b>	<b>6,755.3</b>	Earth @ Stem Transitions =			
				Footing Weight =	875.0	2.50	2,187.5
				Key Weight =		2.50	
				Vert. Component =			
<b>Resisting/Overturning Ratio</b> =			<b>1.67</b>	<b>Total =</b>	<b>3,178.3 lbs</b>	<b>R.M.=</b>	<b>11,275.3</b>
Vertical Loads used for Soil Pressure =		3,178.3 lbs					

\* Axial live load NOT included in total displayed, or used for overturning resistance, but is included for soil pressure calculation.

If seismic is included, the OTM and sliding ratios be 1.1 per section 1807.2.3 of IBC 2009 or IBC 201

Vertical component of active lateral soil pressure IS NOT considered in the calculation of Sliding Resistance.

Vertical component of active lateral soil pressure IS NOT considered in the calculation of Overturning Resistance.

### Tilt

#### Horizontal Deflection at Top of Wall due to settlement of soil

(Deflection due to wall bending not considered)

Soil Spring Reaction Modulus 250.0 pci

Horizontal Defl @ Top of Wall (approximate only) 0.000 in

The above calculation is not valid if the heel soil bearing pressure exceeds that of the toe, because the wall would then tend to rotate into the retained soil.

This Wall in File: d:\dropbox\ck projects\new folder\retaining walls\4ft wall.rpx

RetainPro (c) 1987-2017, Build 11.17.11.03  
License : KW-06059957  
License To : CK Engineering LLC

## Cantilevered Retaining Wall

Code: IBC 2015,ACI 318-14,ACI 530-13

### Criteria

Retained Height	=	10.00 ft
Wall height above soil	=	0.50 ft
Slope Behind Wall	=	0.00
Height of Soil over Toe	=	0.00 in
Water height over heel	=	0.0 ft

### Soil Data

Allow Soil Bearing	=	1,500.0 psf
Equivalent Fluid Pressure Method		
Active Heel Pressure	=	35.0 psf/ft
Passive Pressure	=	150.0 psf/ft
Soil Density, Heel	=	110.00 pcf
Soil Density, Toe	=	0.00 pcf
Footing  Soil Friction	=	0.400
Soil height to ignore for passive pressure	=	12.00 in

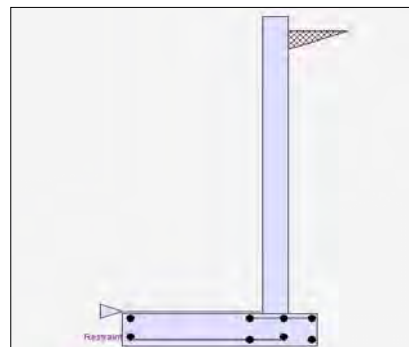

### Surcharge Loads

Surcharge Over Heel	=	100.0 psf
Used To Resist Sliding & Overturning		
Surcharge Over Toe	=	0.0
Used for Sliding & Overturning		

### Lateral Load Applied to Stem

Lateral Load	=	0.0 #/ft
...Height to Top	=	0.00 ft
...Height to Bottom	=	0.00 ft
Load Type	=	Wind (W) (Service Level)
Wind on Exposed Stem	=	0.0 psf (Service Level)

### Adjacent Footing Load

Adjacent Footing Load	=	0.0 lbs
Footing Width	=	0.00 ft
Eccentricity	=	0.00 in
Wall to Ftg CL Dist	=	0.00 ft
Footing Type	=	Line Load
Base Above/Below Soil at Back of Wall	=	0.0 ft
Poisson's Ratio	=	0.300

### Axial Load Applied to Stem

Axial Dead Load	=	500.0 lbs
Axial Live Load	=	0.0 lbs
Axial Load Eccentricity	=	0.0 in

### Earth Pressure Seismic Load

Method : Inverted Triangular			Total Strength-Level Seismic Load. . . . .	=	223.333 lbs
Load at top of Inverted Triangular Distribution . . . . .	=	40.000 psf	Total Service-Level Seismic Load. . . . .	=	156.333 lbs
(Strength)					

### Design Summary

<b>Wall Stability Ratios</b>		
Overturning	=	1.73 OK
Slab Resists All Sliding !		
Total Bearing Load	=	4,006 lbs
...resultant ecc.	=	13.84 in
Soil Pressure @ Toe	=	1,355 psf OK
Soil Pressure @ Heel	=	0 psf OK
Allowable	=	1,500 psf
Soil Pressure Less Than Allowable		
ACI Factored @ Toe	=	1,897 psf
ACI Factored @ Heel	=	0 psf
Footing Shear @ Toe	=	31.8 psi OK
Footing Shear @ Heel	=	10.4 psi OK
Allowable	=	75.0 psi
<b>Sliding Calcs</b>		
Lateral Sliding Force	=	2,609.9 lbs

### Stem Construction

<b>Design Height Above Ftg</b>	ft =	0.00	Stem OK
Wall Material Above "Ht"	=	Concrete	
Design Method	=	LRFD	
Thickness	=	10.00	
Rebar Size	=	# 5	
Rebar Spacing	=	8.00	
Rebar Placed at	=	Edge	
<b>Design Data</b>			
fb/FB + fa/Fa	=	0.831	
<b>Total Force @ Section</b>			
Service Level	lbs =		
Strength Level	lbs =	3,530.0	
<b>Moment....Actual</b>			
Service Level	ft-# =		
Strength Level	ft-# =	13,281.8	
Moment....Allowable	=	15,984.2	
<b>Shear....Actual</b>			
Service Level	psi =		
Strength Level	psi =	35.9	
Shear....Allowable	psi =	75.0	
Anet (Masonry)	in2 =		
Rebar Depth 'd'	in =	8.19	

### Masonry Data

f'm	psi =	
Fs	psi =	
Solid Grouting	=	
Modular Ratio 'n'	=	
Wall Weight	psf =	125.0
Short Term Factor	=	
Equiv. Solid Thick.	=	
Masonry Block Type	=	Medium Weight
Masonry Design Method	=	ASD

### Concrete Data

f'c	psi =	2,500.0
Fy	psi =	60,000.0

Vertical component of active lateral soil pressure IS NOT considered in the calculation of soil bearing

### Load Factors

Building Code	IBC 2015,ACI
Dead Load	1.200
Live Load	1.600
Earth, H	1.600
Wind, W	1.000
Seismic, E	1.000



Use menu item Settings > Printing & Title Block  
to set these five lines of information  
for your program.

Title :  
Job # : Dsgnr: PK  
Description...  
10ft wall (surcharge)

Page : 2  
Date: 30 APR 2018

This Wall in File: d:\dropbox\ck projects\new folder\retaining walls\4ft wall.rpx

RetainPro (c) 1987-2017, Build 11.17.11.03  
License : KW-06059957  
License To : CK Engineering LLC

## Cantilevered Retaining Wall

Code: IBC 2015,ACI 318-14,ACI 530-13

### Concrete Stem Rebar Area Details

Bottom Stem	Vertical Reinforcing	Horizontal Reinforcing
As (based on applied moment) :	0.3751 in2/ft	
(4/3) * As :	0.5001 in2/ft	Min Stem T&S Reinf Area 2.520 in2
200bd/fy : 200(12)(8.1875)/60000 :	0.3275 in2/ft	Min Stem T&S Reinf Area per ft of stem Height : 0.240 in2/ft
0.0018bh : 0.0018(12)(10) :	0.216 in2/ft	Horizontal Reinforcing Options :
	=====	One layer of : Two layers of :
Required Area :	0.3751 in2/ft	#4@ 10.00 in #4@ 20.00 in
Provided Area :	0.465 in2/ft	#5@ 15.50 in #5@ 31.00 in
Maximum Area :	1.1092 in2/ft	#6@ 22.00 in #6@ 44.00 in

#### Footing Dimensions & Strengths

Toe Width	=	4.50 ft
Heel Width	=	1.75
Total Footing Width	=	6.25
Footing Thickness	=	14.00 in
Key Width	=	12.00 in
Key Depth	=	0.00 in
Key Distance from Toe	=	2.00 ft
f'c =	2,500 psi	Fy = 60,000 psi
Minimum Concrete Density	=	150.00 pcf
Min. As %	=	0.0018
Cover @ Top	2.00	@ Btm= 3.00 in

#### Footing Design Results

	Toe	Heel
Factored Pressure	= 1,897	0 psf
Mu' : Upward	= 14,333	11 ft-#
Mu' : Downward	= 2,126	710 ft-#
Mu: Design	= 12,206	700 ft-#
Actual 1-Way Shear	= 31.80	10.38 psi
Allow 1-Way Shear	= 75.00	40.00 psi
Toe Reinforcing	= # 5 @ 10.47 in	
Heel Reinforcing	= # 5 @ 18.00 in	
Key Reinforcing	= None Spec'd	

#### Other Acceptable Sizes & Spacings

Toe: #4@ 6.76 in, #5@ 10.47 in, #6@ 14.86 in, #7@ 20.27 in, #8@ 26.69 in, #9@ 33  
Heel: Not req'd: Mu < phi\*5\*lambda\*sqrt(f'c)\*Sm  
Key: Slab Resists Sliding - No Force on Key

Min footing T&S reinf Area	1.89	in2
Min footing T&S reinf Area per foot	0.30	in2 /ft
If one layer of horizontal bars:		If two layers of horizontal bars:
#4@ 7.94 in		#4@ 15.87 in
#5@ 12.30 in		#5@ 24.60 in
#6@ 17.46 in		#6@ 34.92 in

### Summary of Overturning & Resisting Forces & Moments

Item	.....OVERTURNING.....			.....RESISTING.....			
	Force lbs	Distance ft	Moment ft-#	Force lbs	Distance ft	Moment ft-#	
Heel Active Pressure	= 2,182.2	3.72	8,122.5	Soil Over Heel	= 1,008.3	5.79	5,839.9
Surcharge over Heel	= 271.4	5.58	1,515.4	Sloped Soil Over Heel	=		
Surcharge Over Toe	=			Surcharge Over Heel	= 91.7	5.79	530.9
Adjacent Footing Load	=			Adjacent Footing Load	=		
Added Lateral Load	=			Axial Dead Load on Stem	= 500.0	4.92	2,458.3
Load @ Stem Above Soil	=			* Axial Live Load on Stem	=		
Seismic Earth Load	= 156.3	7.44	1,163.8	Soil Over Toe	=		
	=			Surcharge Over Toe	=		
<b>Total</b>	<b>2,609.9</b>	<b>O.T.M.</b>	<b>10,801.7</b>	Stem Weight(s)	= 1,312.5	4.92	6,453.1
	=	=		Earth @ Stem Transitions	=		
<b>Resisting/Overturning Ratio</b>		=	<b>1.73</b>	Footing Weight	= 1,093.8	3.13	3,418.0
Vertical Loads used for Soil Pressure =		4,006.3	lbs	Key Weight	=	2.50	
				Vert. Component	=		
				<b>Total =</b>	<b>4,006.3</b>	<b>lbs</b>	<b>R.M.= 18,700.3</b>

If seismic is included, the OTM and sliding ratios be 1.1 per section 1807.2.3 of IBC 2009 or IBC 201

Vertical component of active lateral soil pressure IS NOT considered in the calculation of Sliding Resistance.

Vertical component of active lateral soil pressure IS NOT considered in the calculation of Overturning Resistance.

\* Axial live load NOT included in total displayed, or used for overturning resistance, but is included for soil pressure calculation.

Use menu item Settings > Printing & Title Block  
to set these five lines of information  
for your program.

Title :  
Job # : Dsgnr: PK  
Description....  
10ft wall (surcharge)

Page : 3  
Date: 30 APR 2018

This Wall in File: d:\dropbox\ck projects\new folder\retaining walls\4ft wall.rpx

RetainPro (c) 1987-2017, Build 11.17.11.03  
License : KW-06059957  
License To : CK Engineering LLC

## Cantilevered Retaining Wall

Code: IBC 2015,ACI 318-14,ACI 530-13

### Tilt

#### Horizontal Deflection at Top of Wall due to settlement of soil

(Deflection due to wall bending not considered)

Soil Spring Reaction Modulus 250.0 pci

Horizontal Defl @ Top of Wall (approximate only) 0.063 in

The above calculation is not valid if the heel soil bearing pressure exceeds that of the toe,  
because the wall would then tend to rotate into the retained soil.